

SUB-COMMITTEE ON STANDARDS OF
TRAINING AND WATCHKEEPING
43rd session
Agenda item 3

STW 43/3/5
12 September 2011
Original: ENGLISH

VALIDATION OF MODEL TRAINING COURSES

Model Course – Officer in Charge of an Engineering Watch

Note by the Secretariat

SUMMARY

Executive summary: This document contains a revised draft model course on Officer in Charge of an Engineering Watch

Strategic direction: 5.2

High-level action: 5.2.2

Planned output: 5.2.2.5

Action to be taken: Paragraph 3

Related document: STW 40/14

1 Attached in the annex is the revised draft model course on Officer in Charge of an Engineering Watch.

2 The preliminary revised draft of this model course was forwarded to members of the validation panel for their comments. Relevant comments on the revised draft course have been received from the validation panel and incorporated, as appropriate.

Action requested of the Sub-Committee

3 The Sub-Committee is invited to consider the above information and take action as appropriate.

ANNEX

DRAFT IMO MODEL COURSE ON OFFICER IN CHARGE OF AN ENGINEERING WATCH

**Model
Course
7.04**

Officer in Charge of an Engineering Watch



IMO

Acknowledgement

This 2012 Edition of the IMO Model Course on Officer in Charge of an Engineering Watch
was developed by
National Institute for Sea Training
Yokohama, Japan
Tokyo University of Marine Science and Technology
Tokyo, Japan

IMO wishes to express its sincere appreciation to
the Global Maritime Education and Training
for its valuable assistance and cooperation.

CONTENTS

Introduction

Function 1: Marine Engineering at the Operational Level

Part A1: Course Framework	12
Part B1: Course Outline and Guidance Notes	15
Part C1: Detailed Teaching Syllabus	28

Function 2: Electrical, Electronic and Control Engineering at the Operational Level

Part A2: Course Framework	67
Part B2: Course Outline and Guidance Notes	70
Part C2: Detailed Teaching Syllabus	76

Function 3: Maintenance and Repair at the Operational Level

Part A3: Course Framework	103
Part B3: Course Outline and Guidance Notes	106
Part C3: Detailed Teaching Syllabus	118

Function 4: Controlling the Operation of the Ship and Care for Persons on Board at the Operational Level

Part A4: Course Framework	143
Part B4: Course Outline and Guidance Notes	149
Part C4: Detailed Teaching Syllabus	161

Appendices

1 Basic Engineering Science	215
2 Mathematics	218
3 Thermodynamics	221
4 Mechanical Science	225
5 Industrial Chemistry	227

Attachment: Guidance on the implementation of IMO model courses.

Introduction

■ Purpose of the model courses

The purpose of the IMO model courses is to assist maritime training institutes and their teaching staff in organizing and introducing new training courses or in enhancing, updating or supplementing existing training material where the quality and effectiveness of the training courses may thereby be improved.

It is not the intention of the model course programme to present instructors with a rigid "teaching package" which they are expected to "follow blindly". Nor is it the intention to substitute audio-visual or "programmed" material for the instructor's presence. As in all training endeavours, the knowledge, skills and dedication of the instructors are the key components in the transfer of knowledge and skills to those being trained through IMO model course material.

The educational systems and the cultural backgrounds of trainees in maritime subjects vary considerably from country to country. For this reason the model course material has been designed to identify the basic entry requirements and trainee target group for each course in universally applicable terms, and to specify clearly the technical content and levels of knowledge and skill necessary to meet the technical intent of IMO conventions and related to recommendations.

This is the second major revision to this Model Course. In order to keep the training programme up to date in future, it is essential that users provide feedback. New information will provide better training in safety at sea and protection of the marine environment. Information, comments and suggestions should be sent to the Head of the STCW and Human Element Section at IMO, London.

■ Use of the model course

To use the model course the instructor should review the course plan and detailed syllabus, taking into account the information provided under the entry standards specified in the course framework. The actual level of knowledge and skills and the prior technical education of the trainees should be kept in mind during this review, and any areas within the detailed syllabus which may cause difficulties, because of differences between the actual trainee entry level and that assumed by the course designer, should be identified. To compensate for such differences, the instructor is expected to delete from the course, or reduce the emphasis on, items dealing with knowledge or skills already attained by the trainees. He should also identify any academic knowledge, skills or technical training which they may not have acquired.

By analysing the detailed syllabus and the academic knowledge required to allow training in the technical area to proceed, the instructor can design an appropriate pre-entry course or, alternatively, insert the elements of academic knowledge required to support the technical training elements concerned at appropriate points within the technical course.

Adjustment of the course objective, scope and content may also be necessary if in your maritime industry the trainees completing the course are to undertake duties which differ from the course objectives specified in the model course. Within the course plan the course designers have indicated their assessment of the time which should be allotted to each area of learning. However, it must be appreciated that these allocations are arbitrary and assume that the trainees have fully met all entry requirements of the course. The instructor should,

therefore, review these assessments and may need to reallocate the time required to achieve each specific learning objective or training outcome.

■ **Lesson plans**

Having adjusted the course content to suit the trainee intake and any revision of the course objectives, the instructor should draw up lesson plans based on the detailed syllabus. The detailed syllabus contains specific references to the textbooks or teaching material proposed to be used in the course. Where no adjustment has been found necessary in the learning objectives of the detailed syllabus, the lesson plans may simply consist of the detailed syllabus with keywords or other reminders added to assist the instructor in making his presentation of the material.

■ **Presentation**

The presentation of concepts and methodologies must be repeated in various ways until the instructor is satisfied, by testing and evaluating the trainee's performance and achievements, that the trainee has attained each specific learning objective or training objective. The syllabus is laid out in learning objective format and each objective specifies a required performance or, what the trainee must be able to do as the learning or training outcome. Taken as a whole, these objectives aim to meet the knowledge, understanding and proficiency specified in the appropriate tables of the STCW Code.

Implementation

For the course to run smoothly and to be effective, considerable attention must be paid to the availability and use of:

- Properly qualified instructors
- Support staff
- Rooms and other spaces
- Workshops and equipment
- Suggested references, textbooks, technical papers
- Other reference material.

Thorough preparation is the key to successful implementation of the course. IMO has produced a booklet entitled "Guidance on the implementation of IMO model courses", which deals with this aspect in greater detail.

In certain cases, the requirements for some or all of the training in a subject are covered by another IMO model course. In these cases, the specific part of the STCW Code which applies is given and the user is referred to the other model course.

■ Course objective

This model course comprises four functions at the operational level. On successful completion of the training and assessment trainees should be competent to carry out safely the watchkeeping duties of an officer in charge of an engineering watch in a manned engine-room or designated duty engineer in a periodically unmanned engine-room, both at sea and in port. In particular, they will be fully conversant with the basic principles to be observed in keeping an engineering watch as per STCW regulation VIII/2 and STCW Code chapter VIII.

■ Entry standards

Since the minimum age for certification is 18 years, it is expected that in most cases the entry age will be at least 16 years. It is envisaged that trainees will have been in full-time education up to the commencement of training, although in some instances entry will no doubt be made available to those who, having completed full-time education, follow other paths first.

Administrations will wish to specify their own educational standards for entry. With this in mind, attention is drawn to the fact that while the mathematical standards of the courses to be followed are not high, trainees continually use fundamental mathematics as a tool throughout the whole of their training; also, as the principles of applied science and engineering are included at an early stage, it is essential to ascertain the potential and interest in this kind of work before entry. In a similar manner, trainees have to accomplish a range of engineering craft skills, and therefore an aptitude and interest in this direction are also necessary.

Where entrants have not reached the required standards in mathematics or physical science it will be necessary to provide a preparatory course or courses to bring them to the desired level before starting the professional studies. Conversely, topics which have been adequately covered during their general education can be omitted and the allotted time reduced accordingly.

No previous maritime or engineering training is assumed, but those entering the course should be following an approved programme of shipboard training.

■ **Course intake limitations**

Training to acquire engineering skills in workshops will be planned and implemented for a certain period of time. During these periods it is recommended that there are not more than approximately ten trainees to each supervisor/instructor. Depending upon staffing levels and how the timetable and utilization of premises can be arranged, other subjects may be studied in class sizes of not more than 24 in order to allow the instructor to give adequate attention to individual trainees. Larger numbers may be admitted if extra staff and tutorial periods are provided to deal with trainees on an individual basis.

In addition, for scheduling access to learning facilities and equipment, attention to strict time management is necessary. In large classes students should have their own reference books, unless sufficient copies can be provided in a central library. Classrooms should be big enough to seat all students so they can see and hear the instructor.

■ **Textbooks**

A large number of books and publications may be used to study marine engineering. The framework in each function contains details of specified textbooks which are referred to in the syllabus by page number appropriate to the learning objectives. Other books may be considered equally suitable; the chosen books should help trainees to achieve the learning objectives.

Details of additional books which would provide useful library references and further background reading are included where appropriate in each subject.

References to books are made in the syllabuses of the individual subjects to aid both instructors and trainees in finding relevant information and to help in defining the scope and depth of treatment intended.

The mention of a particular textbook does not imply that it is essential to use that book only that it appeared to be best suited to the course at the time of its design. In many instances there are a number of suitable books, and instructors are free to use whatever texts they consider to be most suited to their circumstances and trainees.

Every effort has been made to quote the latest editions of the publications mentioned but new editions are constantly being produced. Instructors should always use the latest edition for preparing and running their courses.

Full use should be made of technical papers and other publications available from maritime and other professional organizations. Such papers contain new developments in techniques, equipment, design, management and opinion and are an invaluable asset to a maritime training establishment.

■ Training and the STCW 2010 Convention

The standards of competence that have to be met by seafarers are defined in Part A of the STCW Code in the Standards of Training, Certification and Watchkeeping for Seafarers Convention, as amended in 2010. This IMO model course has been revised and updated to cover the competences in STCW 2010. It sets out the education and training to achieve those standards.

This course covers the minimum standard of competence for officers in charge of an engineering watch in a manned engine-room or designated duty engineers in a periodically unmanned engine-room, see STCW Code Table A-III/1.

For ease of reference, the course material is organized in four separate Functions as per the STCW Code. These functions are:

- Function 1 Marine engineering at the operational level
- Function 2 Electrical, electronic and control engineering at the operational level
- Function 3 Maintenance and repair at the operational level
- Function 4 Controlling the operation of the ship and care for the persons on board at the operational level.

Each function is addressed in three parts: Part A, Part B and Part C.

Part A provides the framework for the course with its aims and objectives and notes on the suggested teaching facilities and equipment. A list of useful teaching aids, IMO references and textbooks is also included.

Part B provides an outline of lectures, demonstrations and exercises for the course. No detailed timetable is suggested. From the teaching and learning point of view, it is more important that the trainee achieves the minimum standard of competence defined in the STCW Code than that a strict timetable is followed. Depending on their experience and ability, some students will naturally take longer to become proficient in some topics than in others. Also included in this section are guidance notes and additional explanations.

A separate IMO model course addresses Assessment of Competence. This course explains the use of various methods for demonstrating competence and criteria for evaluating competence as tabulated in the STCW Code.

Part C gives the Detailed Teaching Syllabus. This is based on the theoretical and practical knowledge specified in the STCW Code. It is written as a series of learning objectives, in other words what the trainee is expected to be able to do as a result of the teaching and training. Each of the objectives is expanded to define a required performance of knowledge, understanding and proficiency. IMO references, textbook references and suggested teaching aids are included to assist the teacher in designing lessons.

The Convention defines the minimum standards to be maintained in Part A of the STCW Code. Mandatory provisions concerning Training and Assessment are given in Section A-I/6 of the STCW Code. These provisions cover: qualifications of instructors, supervisors and assessors; in-service training; assessment of competence; and training and assessment

within an institution. The corresponding Part B of the STCW Code contains guidance on training and assessment.

The criteria for evaluating competence of officers in charge of an engineering watch specified in the minimum standard of competence tables of Part A of the STCW Code have to be used in the assessment of all competences listed in those tables.

■ **Ships without steam boilers**

The function Marine Engineering at the Operational Level includes competences concerned with the operation of steam boilers. These are addressed in the Detailed Teaching Syllabus in Part C. Candidates for certification for service on ships in which steam boilers do not form part of their machinery may omit the relevant requirements. Certificates so awarded should not be valid for service on ships in which steam boilers form part of their machinery until the engineer officer meets the standard of competence in the items previously omitted. Such limitations are required to be shown on the certificate and in the endorsement.

■ **Responsibilities of Administrations**

Administrations should ensure that training courses delivered by colleges and academies are such as to ensure officers completing training do meet the standards of competence required by STCW regulation III/1 paragraph 2.

■ **Validation**

The information contained in this document has been validated by the Sub-Committee on Standards of Training and Watchkeeping for use by technical advisers, consultants and experts for the training and certification of seafarers so that the minimum standards implemented may be as uniform as possible. *Validation* in the context of this document means that no grounds have been found to object to its content. The Sub-Committee has not granted its approval to the document, as it considers that this work must not be regarded as an official interpretation of the Convention.

Officer in Charge of an Engineering Watch

Function 1:

Marine Engineering at the Operational Level

**Officer in Charge of an Engineering Watch
Function 1: Marine Engineering at the Operational Level**

INDEX

Part A1: Course Framework	12
Aims	
Objective	
Entry standards	
Course certificate	
Staff requirements	
Teaching facilities and equipment	
Teaching aids	
CDs and DVDs	
IMO references	
Textbooks	
Part B1: Course Outline and Guidance Notes	15
Timetable	
Lectures	
Course outline	
Guidance notes	
Part C1: Detailed Teaching Syllabus	28
Introduction	
Explanation of information contained in the syllabus tables	
1.1 Maintain a safe engineering watch	
1.2 Use English in written and oral form	
1.3 Use internal communication systems	
1.4 Operate main and auxiliary machinery and associated control systems	
1.5 Operate fuel, lubrication, ballast and other pumping systems and associated control systems	

Function 1 - Marine Engineering at the Operational Level

Part A1: Course Framework

Aims

This model course aims to meet the mandatory minimum requirements for knowledge, understanding and proficiency in Table A-III/1 of STCW 2010 for the function Marine Engineering at the Operational Level.

Objective

This syllabus covers the requirements of the 2010 STCW Convention Chapter III, Section A-III/1. This functional element provides the detailed knowledge to support the training outcomes related to Marine Engineering at the Operational Level.

This section provides the background knowledge and practical work to support:

- maintaining a safe engineering watch;
- use English in written and oral form;
- use internal communication systems;
- operate main and auxiliary machinery and associated control systems; and
- operate fuel, lubrication, ballast and other pumping systems and associated control Systems.

Entry standards

This course is principally intended for candidates for certification as officers in charge of an engineering watch in a manned engine-room or designated duty engineers in a periodically unmanned engine-room. Those wishing to enter this course should be following an approved programme of onboard training.

Course certificate

On successful completion of the course and assessments, a document may be issued certifying that the holder has successfully completed a course of training which meets or exceeds the level of knowledge and competence specified in Table A-III/1 of STCW 2010, for the function Marine Engineering at the Operational level.

Staff requirements

Instructors shall be qualified in the task for which training is being conducted and have appropriate training in instructional techniques and training methods (STCW Code Section A-I/6). As well as instructors, additional staff will be required for the maintenance of machinery and equipment and for the preparation of materials, work areas and supplies for all practical work.

Teaching facilities and equipment

A classroom equipped with an overhead projector and a blackboard, whiteboard or flipchart should be provided for teaching the theory of the course and holding group discussions.

Teaching aids (A)

- A1 Instructor Guidance (Part B of this course)
- A2 Manufacturers' Manuals
- A3 Video cassette player
- A4 *Marlins* English language Study Pack 1 and Study Pack 2 with audio cassette and teacher's notes (www.marlins.co.uk)

A comprehensive workshop is required for the practical elements in the training objectives.

CDs and DVDs

- V4 Personal safety in the engine-room (Code No. 556)
- V6 Engine-room resource management (Code No. 649)
- V7 Basic marine lubrication series (Code No. 442-444)
- V8 Handling and treatment of heavy fuels (Code No. 143)
- V9 Fuel oil burner theory and diagnostics (Code No. 604)
- V10 Internal care of marine boilers (Code No. 150)
- V11 Centrifugal pumps -theory and operation (Code No. 9)
- V12 Tanker practices -Part 1 & 2 Pumping cargo (Code No. 501, 502)

Available from: Videotel Marine International Ltd.,
84 Newman Street, London W1 P 3LD, UK
Tel: 44 20 7299 1800
Fax: 44 20 7299 1818
e-mail: mail@videotelmail.com
URL: www.videotel.co.uk

- V13 Engine-room resource management
- V14 Marine steam turbine plant

Available from: The Maritime Human Resource Institute, Japan
Kaiji center building, 4-5 Kojimachi
Chiyoda-ku, Tokyo Japan
Tel: 81 3 3265 5126
Fax: 81 3 3264 3808
URL: <http://www.mhrij.or.jp>

IMO References (R)

- R1 International Convention on Standards of Training, Certification and Watchkeeping for Seafarers(STCW), 1995 (IMO Sales No. 938), and 1997 Amendments to STCW 95 (IMO Sales No. 945) and 2010 Amendments to STCW95
- R2 International Convention for the Safety of Life at Sea (SOLAS), as amended (IMO Sales No. 110)
- R3 International Convention for the Prevention of Pollution from Ships, 1973/78(MARPOL) (IMO Sales No. 520) and 1994/95 MARPOL Amendments (IMO Sales No. 640)
- R4 IMO/ILO Document for Guidance, 1985 (IMO Sales No. 935)
- R5 International Safety Management Code (ISM Code) (IMO-186)

Details of distributors of IMO publications that maintain a permanent stock of all IMO publications may be found on the IMO web site at <http://www.imo.org>.

Textbooks (T)

- T21 International Labour Office. Accident Prevention on Board Ship at Sea and in Port, 2nd ed. Geneva, ILO, 1996 (ISBN 92-21-09450-2)
- T24 Jackson, L and Morton, T.D. General Engineering Knowledge for Marine Engineers. 5th ed. London, Thomas Reed Publications Ltd 1990. (ISBN 09-47-63776-1)
- T26 Joel, R. Basic Engineering Thermodynamics in S.I. Units. 5th ed. Harlow, Longmann, 1996 (ISBN 05-82-25629-1)
- T35 Morton, TD Motor Engineering Knowledge for Marine Engineers. London. Thomas Reed Publications Ltd, 1994 (ISBN 09-01-2856-5)
- T50 Taylor, D.A. Introduction to Marine Engineering. 2nd ed. London, Butterworth. 1990 (ISBN 07-50-6253-9)
- T71 Blakey, T.N. English for Maritime Studies. 2nd ed. Hemel Hempstead, Prentice Hall International (UK) Ltd, 1987 (ISBN 0 13 281379-3)

Secondhand copies of out of print books may be available from the Warsash Nautical Bookshop, 6 Dibles Road, Warsash, Southampton SO31 9HZ, UK.

Tel: 44 1489 572 384 Fax: 44 1489 885756

E-mail:orders@nauticalbooks.co.uk URL: www.nauticalbooks.co.uk

Function 1: Marine Engineering at the Operational Level

Part B1: Course Outline and Guidance Notes

Timetable

No formal example of a timetable is included in this model course.

Development of a detailed timetable depends on the level of skills of the trainees entering the course and the amount of revision work of basic principles that may be required.

Lecturers must develop their own timetable depending on:

- the level of skills of trainees;
- the numbers to be trained;
- the number of instructors;
- workshop equipment available;

and normal practices at the training establishment.

Preparation and planning constitute an important factor which makes a major contribution to the effective presentation of any course of instruction.

Lectures

As far as possible, lectures should be presented within a familiar context and should make use of practical examples. They should be well illustrated with diagrams, photographs and charts where appropriate, and be related to matter learned during seagoing time.

An effective manner of presentation is to develop a technique of giving information and then reinforcing it. For example, first tell the trainees briefly what you are going to present to them; then cover the topic in detail; and, finally, summarize what you have told them. The use of an overhead projector and the distribution of copies of the transparencies as trainees handouts contribute to the learning process.

Course Outline

The tables that follow list the competencies and areas of knowledge, understanding and proficiency, together with the estimated total hours required for lectures and practical exercises. Teaching staff should note that timings are suggestions only and should be adapted to suit individual groups of trainees depending on their experience, ability, equipment and staff available for training.

COURSE OUTLINE

Knowledge, understanding and proficiency	Total hours for each topic	Total hours for each subject area of Required performance
Competence		
1.1	MAINTAIN A SAFE ENGINEERING WATCH (30 h)	
1.1.1	THOROUGH KNOWLEDGE OF PRINCIPLES TO BE OBSERVED IN KEEPING AN ENGINEERING WATCH (7 h)	
1.1.2	SAFETY AND EMERGENCY PROCEDURES (8 h)	
1.1.3	SAFETY PRECAUTIONS TO BE OBSERVED DURING A WATCH AND IMMEDIATE ACTIONS TO BE TAKEN (8 h)	
1.1.4	ENGINE-ROOM RESOURCE MANAGEMENT (7 h)	
1.2	USE ENGLISH IN WRITTEN AND ORAL FORM (20 h)	
1.2.1	THE ENGLISH LANGUAGE TO ENABLE THE OFFICER TO PERFORM ENGINEERING DUTIES AND TO USE ENGINEERING PUBLICATIONS (20 h)	
1.3	USE INTERNAL COMMUNICATION SYSTEMS (5 h)	
1.3.1	OPERATION OF ALL INTERNAL COMMUNICATION SYSTEMS ON BOARD (5 h)	
1.4	OPERATE MAIN AND AUXILIARY MACHINERY AND ASSOCIATED CONTROL SYSTEMS (505 h)	
1.4.1	BASIC CONSTRUCTION AND OPERATION PRINCIPLES OF MACHINERY SYSTEMS (405 h)	
	.1 Marine Diesel Engine (100 h)	
	.2 Marine Steam Turbine (50 h)	
	.3 Marine Gas Turbine (15 h)	
	.4 Marine Boiler (40 h)	
	.5 Shafting Installations and Propeller (20 h)	
	.6 Other Auxiliaries (115 h)	
	.7 Steering Gear (20 h)	
	.8 Automatic Control Systems (20 h)	
	.9 Fluid Flow and Characteristics of Major Systems (15 h)	
	.10 Deck Machinery (10 h)	
1.4.2	SAFETY AND EMERGENCY PROCEDURES FOR OPERATION OF PROPULSION PLANT MACHINERY INCLUDING CONTROL SYSTEMS (30 h)	
	.1 Main Engine Auto-slow Down and Shut Down (10 h)	
	.2 Main Boiler Auto shut Down (10 h)	
	.3 Power Failure (5 h)	
	.4 Emergency Procedures for Other Equipment/Installations (5 h)	
1.4.3	PREPARATION, OPERATION, FAULT DETECTION AND NECESSARY MEASURES TO PREVENT DAMAGE FOR THE FOLLOWING MACHINERY ITEMS AND CONTROL SYSTEMS (70 h)	
	.1 Main Engine and Associated Auxiliaries (16 h)	
	.2 Boiler and Associated Auxiliaries, and Steam Systems (16 h)	
	.3 Auxiliary Prime Movers and Associated Systems (8 h)	
	.4 Other Auxiliaries (30 h)	

- 1.5 OPERATE FUEL, LUBRICATION, BALLAST AND OTHER PUMPING SYSTEMS AND ASSOCIATED CONTROL SYSTEMS (40 h)**
- 1.5.1 OPERATIONAL CHARACTERISTICS OF PUMPS AND PIPING SYSTEMS INCLUDING CONTROL SYSTEMS (10 h)**
- 1.5.2 OPERATION OF PUMPING SYSTEMS (22 h)**
 - .1 Routine Pumping Operation (2 h)
 - .2 OPERATION OF BILGE, BALLAST AND CARGO PUMPING SYSTEMS (20 h)
- 1.5.3 OILY WATER SEPARATOR/SIMILAR EQUIPMENT AND OPERATION (8 h)**

Total for Function1: Marine Engineering at the Operational Level 600 hours

Teaching staff should note that the hours for lectures and exercises are suggestions only as regards sequence and length of time allocated to each objective. These factors may be adapted by lecturers to suit individual groups of trainees depending on their experience, ability, equipment and staff available for teaching.

Guidance Notes

The following notes are intended to highlight the main objectives or training outcomes of each part of the function. The notes also contain some material on topics which are not adequately covered in the quoted references.

This function is extensive and covers many different areas, including: the application of the principles to be followed in keeping an engineering watch as required by the STCW Code Chapter VIII; operating main and auxiliary machinery and associated control systems and operating pumping systems for fuel, lubrication, bilges, ballast and cargo.

Function 1: Marine Engineering at the Operational Level

- 1.1 Maintain a Safe Engineering Watch (30 hours)**
- 1.1.1 THOROUGH KNOWLEDGE OF PRINCIPLES TO BE OBSERVED IN KEEPING AN ENGINEERING WATCH (7 hours)**

The standards regarding watchkeeping to be adopted by engineer watchkeepers are contained in the relevant parts of Chapter VIII of the STCW Code. Note that regulation VIII/1 contains new provisions concerned with hours of rest and prevention of drug and alcohol abuse for watchkeeping personnel.

- 1.1.2 SAFETY AND EMERGENCY PROCEDURES (8 hours)**

This topic highlights what is necessary to keep a safe engineering watch and to address an emergency situation. This is also based on the relevant parts of Chapter VIII of the STCW Code.

- 1.1.3 SAFETY PRECAUTIONS TO BE OBSERVED DURING A WATCH AND IMMEDIATE ACTIONS TO BE TAKEN (8 hours)**

More specific ways, manners and precautions to undertake an engineering watch can be learned in this topic. Instructors should teach trainees what these elements/factors mean, taking into account the relevant parts of Chapter VIII of the STCW Code as well.

1.1.4 ENGINE-ROOM RESOURCE MANAGEMENT (ERM) (7 hours)

This topic was added with the introduction of ERM requirement into the competence Table A-III/1 due to the 2010 amendments to the STCW Convention and Code. Although there is no formal definition of ERM, the concept of ERM could be learned and the human elements specified in the Table A-III/1 necessary for practicing ERM should be learned. In this subject, ERM principles described in Chapter VIII of the STCW Code should be also learned.

1.2 USE ENGLISH IN WRITTEN AND ORAL FORM (20 hours)

1.2.1 THE ENGLISH LANGUAGE TO ENABLE THE OFFICER TO PERFORM ENGINEERING DUTIES AND TO USE ENGINEERING PUBLICATIONS (20 hours)

See IMO Model Course

A new IMO model course on Maritime English based on a clearly defined entry standard in general English, deals with maritime terminology and the use of English sufficient to allow the use of engineering publications and the performance of engineering duties concerned with the ship's safety and operation.

The course also includes the vocabulary needed to make use of and understand manufacturers' technical manuals and specifications to converse with technical shore staff concerning ship and machinery repairs.

1.3 USE INTERNAL COMMUNICATION SYSTEMS (5 hours)

1.3.1 OPERATION OF ALL INTERNAL COMMUNICATION SYSTEMS ON BOARD (5 hours)

Internal Communication Systems on Board

Instructors should refer to references for further guidance on this topic.

1.4 OPERATE MAIN AND AUXILIARY MACHINERY AND ASSOCIATED CONTROL SYSTEMS (505 hours)

1.4.1 BASIC CONSTRUCTION AND OPERATION PRINCIPLES OF MACHINERY SYSTEMS (405 hours)

Heat-Engine Cycle

Instructors should read the training outcome (Appendix 3: Thermodynamics), which is based on the same textbook, in order to assist the continuity of the various subject areas.

In some cases the references in the textbook take the subject matter to a level which is more advanced than required in the watchkeeping certificate. Later study for the chief and second engineer officer certificates will take each subject further. The textbook references are intended to guide the instructor who will need to draw up notes for the use of trainees. Without such notes the trainees would probably be confused by the depth of treatment in the book. The specific training outcomes make a clear statement of the level to be achieved by the trainees.

It is not intended that the concept of entropy should be used. The use of P-V diagrams should give an adequate depth of understanding.

Ideal-Gas Cycle

Trainees should already be able to explain the meaning of the processes described in training this function.

When covering the ideal gas cycles, the Carnot cycle may be included if thought necessary, although the main purpose is to relate theoretical cycles to real practice. The numerous pressure, volume and temperature relationships shown in the text should not be used.

There is no book reference to training outcome Single acting or Double acting. A simple explanation of the marine applications is all that is required.

Fuels

Trainees should have had an introduction to fuel oil in their earlier work. The chemical equations for the combustion of fuels are not included; marine engineers do not use these and it is questionable whether their use would add anything to the performance of a practicing marine engineer.

Trainees need to know that hydrocarbons require oxygen, and hence air, for combustion and the elements involved. The combustion equations are not essential and would not be used in practice at sea. Knowledge of the incomplete combustion of carbon is important. The fact that hydrogen burns to produce steam is also important. The products of the combustion of sulphur need highlighting because of the harmful effects of the resultant sulphuric acid. This is dealt with when studying for more advanced certificates.

It will be necessary to explain that the salts of sodium and vanadium included can cause problems, and this is dealt with in later studies.

Combustion

Trainees should learn in combustion that this should be complete and there should be no carbon monoxide present. If there is good atomization of the fuel, it rapidly reaches its ignition temperature, there is adequate mixing of fuel with air and sufficient time is available. If there is evidence of unburnt fuel in the combustion chamber then obviously not all combustion has been complete.

In addition to the textbook reference it should be said that nitrogen reduces the flame temperature and, in a diesel engine, expands during the working stroke, transferring work to the piston.

For a diesel engine the air/fuel ratio used should be that at normal full power. At other loads the ratio could be quite high, depending on the matching of the turbo charger to the engine characteristics.

Engine Types

Visits to a manufacturer's premises can be an advantage but often these are too far away to be of use. Alternatively, such a visit by the instructor can be of considerable value. Ship visits might be more convenient and if used should be carefully planned; it should be decided beforehand what training outcomes can be achieved and whether the expense of time and money is justified.

Marine Diesel Engines

Manufacturers of low and medium speed engines, of which there are many, are normally pleased to supply colleges with copies of their operation and maintenance manuals. It is recommended that colleges obtain manuals appropriate to the engines which trainees are likely to encounter. These manuals give precise details of bearing clearances, dismantling procedures, running temperatures and pressures, etc. and will encourage trainees to refer to manuals for expert guidance when they return to sea.

The training outcome *cycle dimensions, length of stroke, power and rotation speed* has attempted to place engines into two groups:

- (1) Large-bore, running at low speed, normally using direct drive, fitted with piston rods and guides;
- (2) Smaller bore, running at medium- and high-speeds and fitted with trunk pistons. The purpose is to ensure that the rest of the subject is covered using descriptions and terminology which will be understood. The objectives are self explanatory. They cover areas where overlaps occur and precise demarcation is not possible. Nevertheless, trainees will need to use and be aware of the use of these general descriptions because they are frequently used in the profession.

It would be beneficial if trainees could be given actual indicator diagrams. With a low-speed engine, access to the indicator position is sometimes difficult and the surroundings can be uncomfortably hot. This, along with the necessity to remove and re-fit the instrument to each cylinder in a series of sequential operations, can make the process arduous. Also, with the introduction of electronic power-measuring indicators, it is still important to be familiar with traditional methods of power measurement.

Mechanically operated indicators are unsuitable for higher speed engines and the more sophisticated instruments required are not normally carried on ships.

The compression and maximum pressures given in the textbook, *Compression Pressures*, are typical of many engines but for smaller bore engines, which also usually run at higher speeds, the maximum pressures can be in excess of 100 bar.

Supercharge air pressures vary with the make of engine and the age of its design, but generally pressures are in the region of 0.3 to 2.0 bar. Higher pressures are found in high-performance four-stroke engines.

Trainees should have records of all of the systems, pressures, temperatures, etc. referred to in objectives 1.6.1.16, 1.6.1.17, and 1.6.1.18 as a result of their seagoing assignments. It is recommended that such records are compared to the book references in order to check for accuracy and their acceptance for general application.

Although not applied to all engines, the principles of the jerk fuel pump are adequate to cover training outcomes for fuel pump injection systems.

It is important that the detector for indicating hazardous engine crankcase conditions is in good working order and is not giving false alarms, and frequent and careful maintenance is therefore essential. Check whether the Administration or shipowners have laid down their requirements and, if so, pass these onto the trainees. In the absence of company or other guidance, the procedure would be: inform the chief engineer immediately; piston cooling returns should be quickly checked and indications of local increase of temperature noted; inform the bridge and stop the engine; wait, to provide a long cooling period; open up the crankcase at the suspected unit.

For the training outcome referring to *scavenge spaces* it is necessary to emphasize that drains need to be kept clear of obstruction and opened regularly. Spaces need to be kept clear of oil, dust, water, unburnt fuel and any other deposits by regular inspection and, when necessary, cleaning. Failure to do this is likely to lead to an outbreak of fire.

A shipowner may issue standing instruction on the procedure to follow covering training outcome *scavenge fires*. The procedure might be: inform the chief engineer and the bridge; cut off the fuel to the unit in question (a small fire might burn itself out); reduce total engine power and finally inject fire-extinguishing media. If the trunking containing the fire is adjacent to other potential dangers, such as the crankcase, then cool it with water.

The procedures to meet training outcome *turbo charger surge* should include a statement that a turbo charger should not be allowed to continue surging. Also, the immediate remedy is to reduce the engine power and then slowly increase it again. Measures for the prevention of this occurrence are the responsibility of the chief engineer.

Rankine Cycle

This training outcome should be helped by a sketch of a P-V diagram. Again, entropy should not be included. Note that the steady-flow equation has not been covered and is not required at this stage.

Steam plant components use only the principles of marine applications.

Marine Boiler Construction

When covering this objective, the instructor should note that trainees do not cover the stress in the shell of a pressure vessel until studying for more advanced certificates.

Trainees should have learnt how to expand a tube when completing their training in marine engineering skills.

Boiler Mountings and Steam Distribution

In this objective, most of the valves and internal fittings are essential to a steam boiler. However, in some cases scumming and soot-blowing facilities might not be provided.

Marine Boiler Operation

Raising steam and coupling a boiler into the steam system should have been covered in the seagoing phase. The important points are to:

- drain water from steam lines coming into use;
- raise steam pressure slowly to that in the main to be supplied;
- open the main steam valve very slowly;
- adjust the heat input to the other boiler(s);
- open the feed valve to the new boiler; and
- reduce the heat input and feedwater supply to the existing boiler.

The operation procedures may have been covered in the seagoing phase. The important points are to adjust the heat and feedwater inputs to each boiler according to the required share of the load.

In normal operation, with the boiler and feedwater quality as they should be, water-level gauge fittings should not become blocked. The movement of a ship at sea causes the level of the boiler water to rise and fall continuously, and this usually indicates that all is well; this partly covers this objective. Also, as a regular check, and if any doubt arises, the procedures given in the textbook should be followed.

When covering the dangers of low level water, trainees should learn that if a shortage of water in a boiler causes parts to be uncovered which are exposed to heat from the combustion of fuel then the temperature of those parts will rise rapidly. Distortion will occur, due to excessive expansion of the metal. If the rise in temperature continues, the pressure in the boiler will cause serious distortion or rupture of the weakened metal. On the other hand a high water level in a boiler may lead to priming and to carry-over of water in the steam.

Administrations may have given instruction on the procedure to cover the event in this objective. If not, trainees should learn that if it can be determined without doubt that heat-transfer surfaces have not been exposed, then increasing the feedwater rate will raise

the level of water in a boiler without damage. If there is the possibility that heat-transfer surfaces have been exposed then they should immediately extinguish the fire(s) in the boiler, reduce the boiler pressure by opening the safety valves and shut off the feedwater supply.

The Chief Engineer should be informed. Any exposed parts must be given time to return to their normal working temperature before re-opening the feedwater supply. In the meantime, all vulnerable parts should be inspected as far as possible to check for damage. If all is well, the boiler can be brought slowly back into service, with regular checks being made for leaks at joints and distortion of heating surfaces.

The purpose of settling tanks and the maintenance procedures for oil-burning equipment should have been covered during the seagoing phase. It should, therefore, only be necessary to ascertain that trainees can comply with the objectives as specified.

The maintenance of good combustion, avoidance of the accumulation of combustible deposits and adequate cleaning of uptake passages will avoid uptake fires.

Trainees should know that an uptake fire might be detected by a rise in the temperature of the combustion air from the air heater or a rise in the temperature of the steam from the superheater, if one is fitted. Alternatively, smell and smoke might be the first indication. Standing instructions should be followed; if there are none, a watchkeeping engineer should call the Chief Engineer and shut off all fuel and air supply to the boiler. If further action is necessary, smother the boiler's internal gas paths with CO₂, or similar, and cool the outside of the casing to prevent the external paint coatings, etc. catching fire.

Steam Boiler Fuel Atomization and Combustion

When covering the last objective in this section, it is important to emphasize that observation into the furnace should be through a dark glass filter. The atmosphere around the flame should be clear and the flame should be stable and bright.

Principles of Pumping

The engineer officer in charge of a watch is responsible for a variety of pumping operations about the ship. Many systems are continuous, with flow rates being controlled either manually or automatically, whereas others are brought into use according to demand, again either automatically or manually. It is, therefore, important that an engineer should know sufficient to ensure that the systems are used, or are working, correctly. The recommended equipment can be made up of used components obtained from shipping companies or from ship breakers. The dismantling and sectioning of this equipment are useful exercises for trainees when acquiring engineering skills.

Volume and mass flows are covered in Appendix 4, Mechanical Science, but may need revision for this objective.

Types of Pump

During their seagoing phase, trainees will have used a variety of pumps. Care is necessary to ensure that the correct names have been learnt (V11 and V12).

In the early part of their training trainees will have practiced dismantling various pumps and, therefore, should have some prior knowledge and record of the requirements of the objectives under this section. Sectioned or dismantled pumps or models would be of considerable benefit.

Instructors should note when describing this section, axial-flow pumps are not found in all ships and may not have been seen by trainees.

Trainees may experience the use of ejectors, for ballast-stripping purposes in bulk carriers.

Marine Refrigeration Cycle

Refrigeration system components. A portable refrigeration demonstration unit can be used to advantage.

Principles of Refrigeration

Trainees may have had experience on ships with large-scale refrigeration plant. However, on the majority of ships, refrigeration is limited to domestic cold stores.

For objective 1.4.1.2, the Rankine cycle and its application to refrigeration will have been covered in Training outcome 1, **Marine Heat Engines**.

The basic circuit and its function, as required in this objective, are covered in Training outcome 1, **Marine Heat Engines**. It is unlikely that the practical aspects, such as oil separation and charging, would have been covered.

Refrigerating Compressors and System Components

These objectives are best covered by providing trainees with the actual parts, dismantled and sectioned where appropriate.

Heat Exchangers

Trainees are not likely to encounter contact heat exchangers. The paragraph on 'contact heat transfer' is simply to create an awareness of their existence.

The two most common types of construction of heat exchangers are named in this section. If it is anticipated that trainees may experience other types then these should be added.

Evaporators and Distillers

Depending on the type of ship and the trade patterns experienced during their seagoing phase, some trainees may have previously operated evaporators and therefore should already be in a position to accomplish some of the objectives laid down in the syllabus. Nevertheless it is important to ensure that all trainees, regardless of previous experience, understand the function and correct operation of evaporators sufficiently well to be able to follow instructions laid down by the chief engineer.

It may be possible to obtain instruction manuals from suppliers of evaporators, in which case these should be made available to trainees and be also used along with the recommended text.

Trainees should be able to complete a list of the purposes for which water might be used, as a result of their seagoing experience.

Distillation can be demonstrated using water samples.

It should be possible to obtain used evaporator mountings etc., from shipowners or ship breakers.

Administrations may issue more precise regulations regarding seawater than indicated, in which case they should be adopted.

Air Compressors and System Principles

Trainees will have had operational experience of air compressors during their seagoing phase which should have included some routine maintenance procedures.

Compressor manufacturers' manuals should be easily obtainable and trainees should be encouraged to refer to these whenever appropriate. Trainees should be able to complete a list of shipboard uses for compressed air, as a result of their seagoing experience.

Steering Gear Principles

Trainees will have gained some experience of steering gears during their seagoing phase. Instructors should take care to ensure that this experience is enhanced by this subject and that trainees' observations and records are acceptable.

Many losses of ships and accidents have occurred through the malfunctioning of steering gears. It is, therefore, of great importance that the engineer officer in charge of a watch is competent to ensure the continual availability of steering control and power.

A simple diagram, similar to that shown below, would be quite adequate to meet this objective

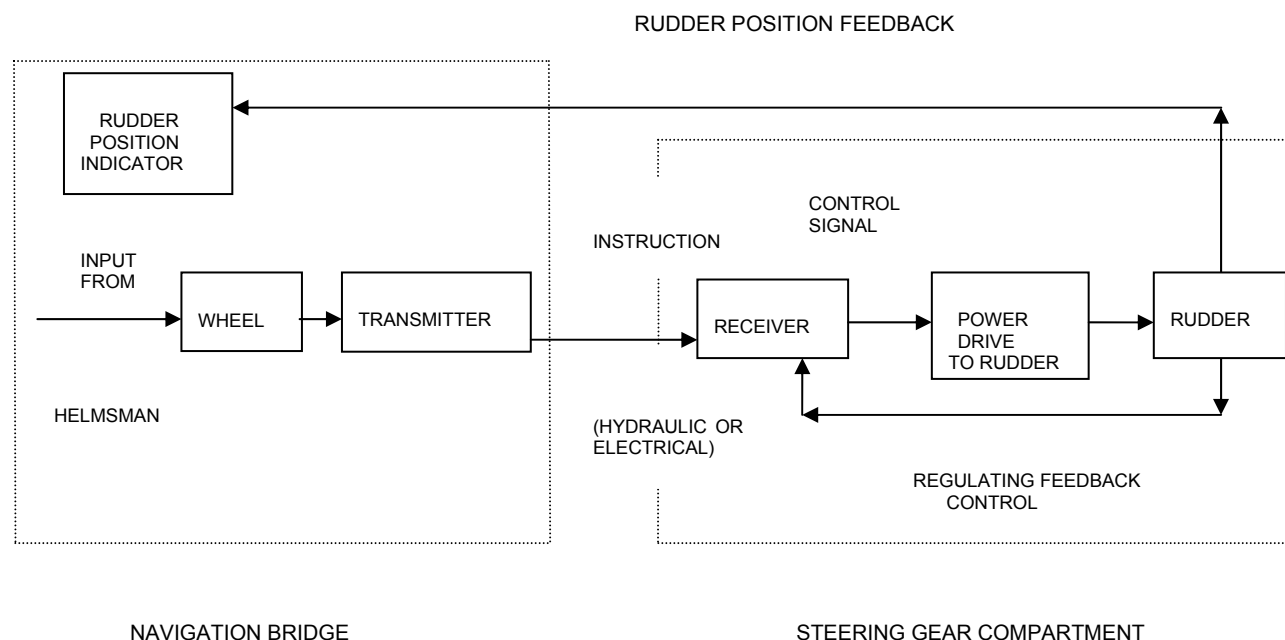

DIAGRAMMATIC ARRANGEMENT OF A MANUALLY OPERATED STEERING SYSTEM

Fluid Flow and Characteristics of Major Systems

Trainees should have made joints and connected pipes during their skill training. It is, however, necessary for explaining the sealing of joints to ensure that they have retained the correct knowledge.

The arrangements of ports in a plug is not referred to in the textbooks but trainees must be made aware of the line markings indicating through-flow parts, right-angled ports and a 'tee' arrangement of ports.

The description of a hydraulic system should have been included in the skill-training period; nevertheless, it is important to ensure that trainees know of the use of both spectacle and tabbed or spade blanking plates.

1.4.2 SAFETY AND EMERGENCY PROCEDURES FOR OPERATION OF PROPULSION PLANT MACHINERY INCLUDING CONTROL SYSTEMS (30 hours)

Propulsion Plant Operation

The purpose of this subject is to give trainees an insight into some of the activities which they will be trained to perform during the seagoing phase. Later, when they continue their studies ashore, trainees will cover each topic again, possibly in a classroom environment, to reach the standard required to qualify as engineer officer in charge of a watch.

Trainees will have had some experience of machinery maintenance during which they should have made sketches and taken notes. However, it will be necessary for instructors to prepare schematic arrangements, etc. to ensure that trainees understand the principles. Considerably more detailed knowledge will be gained later both on board ship and then when back in the training establishment.

Wherever possible, trainees should be encouraged to refer to the instructions given in manufacturers' manuals, which are normally easily obtainable direct or from their agents.

At this stage trainees cannot become competent in the operation of marine plant, this will come with further experience and training.

Principles should be applied which will enable trainees later during their seagoing phase to gain full advantage of the experience and training available on board ship.

It is important that trainees achieve the specific training outcomes. However, the order in which these are accomplished is not important. In some cases it will be necessary to rearrange the order printed in the syllabus to accommodate the sequence dictated by a particular job. In all cases, it must be ensured that trainees are competent in basic skills before proceeding to more advanced training outcomes.

The list should include:

- obtaining permission;
- informing other personnel who might be affected;
- entries in the engine-room log-book;
- completion of any maintenance etc.;
- cooling water flow;
- lubrication supply;
- security of guards;
- unobstructed movement internally and externally;
- all valves correctly opened or closed;
- availability of electrical load.

Where running machinery cannot be used, trainees will have to describe the procedures. Extracts from manufacturers' manuals should be made wherever possible.

As machinery in a training establishment usually runs without abnormality, instructors will have to superimpose imaginary readings on those actually taken to meet objective 1.1, in order to indicate malfunctioning.

Trainees need to know of the basic symptoms of malfunction, i.e. those related to pressure, temperature, speed, noise, vibration, fume vapour, smoke and smell.

Trainees should not be given sole responsibility for overseeing the operation of machinery. Their first priority is to report immediately suspected faults to an officer, who should then take appropriate action. Nevertheless, trainees should be made aware of the steps to be taken in simple cases.

For pressures and temperatures it is suggested that reference is made to the appropriate manuals; alternatively, data may be obtained for the type of engine that trainees are likely to encounter.

1.4.3 PREPARATION, OPERATION, FAULT DETECTION AND NECESSARY MEASURES TO PREVENT DAMAGE FOR THE FOLLOWING MACHINERY IEMS AND CONTROL SYSTEMS (70 hours)

A watchkeeping officer can face various emergencies and machinery malfunctions, some of which can be difficult to address. In this topic, the instructor should encourage lateral thinking and it is important to have a discussion in order to find a better solution. This approach will cultivate the trainee's sense of engineering and assist in obtaining the information necessary to reach a solution. The information will include operation mechanisms and principles and construction of ship's propulsion machinery. This will improve the trainee's understanding of this subject.

1.5 OPERATE FUEL, LUBRICATION, BALLAST AND OTHER PUMPING SYSTEMS AND ASSOCIATED CONTROL SYSTEMS (40 hours)

1.5.1 OPERATIONAL CHARACTERISTICS OF PUMPS AND PIPING SYSTEMS INCLUDING CONTROL SYSTEMS (10 hours)

Pump Operation

Trainees should have dismantled and refitted the glands and seals described in this objective during their early training; they also may have adjusted same while training at sea. It is, however, still important to ensure, as far as possible, that adjustable glands are correctly packed and lubricated and are not over-tightened, and that trainees know of the care necessary to maintain seals in good working order.

1.5.2 OPERATION OF PUMPING SYSTEMS (22 hours)

Bilge Pumping Systems

Trainees should have drawn a diagram of a bilge pumping system during the seagoing phase. It is important that they can recall this information, as required by this objective, and that is acceptable.

Instructors need to be familiar with the relevant parts of reference R1 and/or national administration regulations. Trainees need to be aware of the existence of the regulations but at this stage do not need to quote detail other than that specified in learning these objectives.

The fire main, as part of the fixed fire-fighting installation, is covered in the training on fire fighting. It is included in this module to ensure that the watchkeeping engineer is fully aware of the provision and of his responsibilities in making available an ample supply of water at all times.

1.5.3 OILY WATER SEPARATOR/SIMILAR EQUIPMENT REQUIREMENTS AND OPERATION (8 hours)

Prevention of Pollution

For this objective it is essential that instructors refer to the relevant parts of the reference book R3 and of the regulations of the national administration. Trainees need to be aware of these but should not be expected to quote text (V1).

Trainees will have pumped bilges and probably used ballast systems during their seagoing phase. It follows, therefore, that they will have used an oily-water separator/similar equipment and made entries in the Oil Record Book. However, the subject is so important that repetition is necessary to reinforce past experience and to ensure that correct procedures will be maintained in the future, (V7).

Part C1: Detailed Teaching Syllabus

Introduction

The detailed teaching syllabus is presented as a series of learning objectives. The objective, therefore, describes what the trainee must do to demonstrate that the specified knowledge or skill has been transferred.

Thus each training outcome is supported by a number of related performance elements in which the trainee is required to be proficient. The teaching syllabus shows the *Required performance* expected of the trainee in the tables that follow.

In order to assist the instructor, references are shown to indicate IMO references and publications, textbooks and teaching aids that instructors may wish to use in preparing and presenting their lessons.

The material listed in the course framework has been used to structure the detailed teaching syllabus; in particular,

- Teaching aids (indicated by A);
- IMO references (indicated by R); and
- Textbooks (indicated by T),

will provide valuable information to instructors.

Explanation of Information Contained in the Syllabus Tables

The information on each table is systematically organized in the following way. The text above the line at the head of the table describes the FUNCTION with which the training is concerned. A function means a group of tasks, duties and responsibilities as specified in the STCW Code. It describes related activities which make up a professional discipline or traditional departmental responsibility on board.¹

¹ Morrison, W.S.G. *Competent crews = safer ships*. Malmö, WMU Press, 1997
(ISBN 91-973372-0-X)

In this model course there are four functions:

- Marine engineering at the operational level;
- Electrical, electronic and control engineering at the operational level;
- Maintenance and repair at the operational level;
- Controlling the operation of the ship and care for the persons on board at the operational level.

The header of the first column denotes the COMPETENCE concerned. Each function comprises a number of competences.

For example, the **FUNCTION: MARINE ENGINEERING AT THE OPERATIONAL LEVEL**, comprises a total of five COMPETENCES. Each competence is uniquely and consistently numbered in this model course.

The first is **Maintain a safe engineering watch**. It is numbered 1.1 that is the first competence in Function 1. The term competence should be understood as the application of knowledge, understanding, proficiency, skills and experience for an individual to perform a task, duty or responsibility on board in a safe, efficient and timely manner.

Shown next is the required TRAINING OUTCOME. The training outcomes are the areas of knowledge, understanding and proficiency in which the trainee must be able to demonstrate knowledge and understanding. Each COMPETENCE comprises a number of training outcomes. For example, the competence "Maintain a safe engineering watch" comprises a total of four training outcomes. The first is in THOROUGH KNOWLEDGE OF PRINCIPLES TO BE OBSERVED IN KEEPING AN ENGINEERING WATCH. Each training outcome is uniquely and consistently numbered in this model course. "Thorough knowledge of principles to be observed in keeping an engineering watch" is numbered 1.1.1. For clarity, training outcomes are printed in black on grey, for example TRAINING OUTCOME.

Finally, each training outcome embodies a variable number of Required performances as evidence of competence. The instruction, training and learning should lead to the trainee meeting the specified required performance. For the training outcome Characteristics and limitations of Materials used in construction and repair of ships and equipment, there are two areas of performance. These are:

1.1.1 Thorough knowledge of principles to be observed in keeping an engineering watch

1.1.2 Safety and emergency procedures

Following each numbered area of Required performance there is a list of activities that the trainee should complete and which collectively specify the standard of competence that the trainee must meet. These are for the guidance of teachers and instructors in designing lessons, lectures, tests and exercises for use in the teaching process. For example, under the topic 1.1.1 Thorough knowledge of principles to be observed in keeping an engineering watch to meet the Required performance, the trainee should be able to:

- Explains principles to be observed in an engineering watch at sea and in port, including following based on the provisions concerned in the STCW Code Ch VIII, Section A-VIII/1, A-VIII/2 and B-VIII/2:
 - duties associated with taking over a watch and accepting a watch;
 - routine duties undertaken during a watch;
 - maintenance of the machinery space logs and the significance of the reading taken;
 - duties associated with handing over a watch,
 - Explains standards/regulations for watchkeeping in a national law if any
 - States the importance, ordinance and arrangements of watchkeeping, and the need to:
 - wear appropriate clothes, safety shoes and a safety helmet;
 - carry a torch lamp;
 - maintain bodily functions;
 - be awake and highly consciousness
- and so on.

IMO references (Rx) are listed in the column to the right hand side. Teaching aids (Ax), videos(Vx) and textbooks(Tx) relevant the training outcome and required performances are placed immediately following the TRAINING OUTCOME title.

It is not intended that lessons are organized to follow the sequence of Required performances listed in the Tables. The Syllabus Tables are organized to match with the competence in the STCW Code Table A-III/1. Lessons and teaching should follow college practices. It is not necessary, for example, for "Thorough knowledge of principles to be observed in keeping an engineering watch" to be studied before "Safety and emergency

procedures". What is necessary is that all the material is covered and that teaching is effective to allow trainees to meet the standard of the Required performance.

COMPETENCE 1.1	Maintain a Safe Engineering Watch	IMO Reference
----------------	-----------------------------------	---------------

TRAINING OUTCOMES:

Demonstrates a knowledge and understanding of :

STCW CODE
Table A-III/1

**1.1.1 THOROUGH KNOWLEDGE OF PRINCIPLES TO BE OBSERVED
IN KEEPING AN ENGINEERING WATCH**

1.1.2 SAFETY AND EMERGENCY PROCEDURES

**1.1.3 SAFETY PRECAUTIONS TO BE OBSERVED DURING A WATCH
AND IMMEDIATE ACTIONS TO BE TAKEN**

1.1.4 ENGINE-ROOM RESOURCE MANAGEMENT (ERM)

COMPETENCE 1.1	Maintain a Safe Engineering Watch	IMO Reference
----------------	-----------------------------------	---------------

1.1.1 THOROUGH KNOWLEDGE OF PRINCIPLES TO BE OBSERVED IN KEEPING AN ENGINEERING WATCH (7 hours)

Textbooks:

Teaching aids: A1, A3, V4, V6, V13

**STCW Code Ch □
Section A-VIII/1
para 10,
Section A-VIII/2
Part 4 para 9-12
Part 4-2 para 52-83
Part 5 para 90-97
Part 5-2 para 100-101
Part 5-4 para 103-104
Section B-VIII/1
Para 6-9
Section B-VIII/2
Part 4-2 para 6-8**

Required performance:

- Explains principles to be observed in an engineering watch at sea and in port, including following based on the provisions concerned in the STCW Code Ch VIII, Section A-VIII/1, A-VIII/2 and B-VIII/2
 - duties associated with taking over a watch and accepting a watch
 - routine duties undertaken during a watch
 - maintenance of the machinery space logs and the significance of the reading taken
 - duties associated with handing over a watch
- Explains standards/regulations for watchkeeping in a national law if any
- States the importance, ordinance and arrangements of watchkeeping, and the need to:
 - wear appropriate clothes, safety shoes and a safety helmet;
 - carry a torch lamp;
 - maintain bodily functions;
 - be awake and highly consciousness

1.1.2 SAFETY AND EMERGENCY PROCEDURES (8 hours)

R1

Textbooks:

Teaching aids: A1, A3, V4, V6, V13

Required performance:

- States what is meant by emergency in accordance with components of the machinery
- States that the type of impact of the emergency should be promptly identified and countermeasures conforming to the emergency procedures and contingency plans established beforehand, should be taken
- States that changeover of remote/automatic control to local operation of all systems has to be almost always done in case of emergency to take actions necessary for maintaining a safe operation
- States that each component/installation constructing propulsion machinery can be isolated from the entire system and can be run manually
- Explains remedial/emergency procedures and conditions in accordance with components of the machinery in such an event of power failure
- Explains necessary procedures/measures with isolation of the component/installation of major machinery, taking examples such as arrangements/managements of piping systems, control systems and other elements concerned
- States procedures for recovery and malfunctions considered to be likely occurred in steering gears in case of blackout and other causes including procedures for changeover of remote-auto to electric hydraulic driven at machine side and hand pump hydraulic driven at machine side respectively

1.1.3 SAFETY PRECAUTIONS TO BE OBSERVED DURING A WATCH AND IMMEDIATE ACTIONS TO BE TAKEN (8 hours) R1

Textbooks:

Teaching aids: A1, A3, V4, V6, V13

Required performance:

- Explains the importance of engine-room rounds before taking over the watch and periodic rounds during the watch
- Explains the need to be at places where communication with bridge and chief engineer is always available except engine-room rounds or carrying communication means
- Explains the need to have an incentive and positive mental attitude emphasizing that officers in charge of the engineering watch assume a great responsibility in the safe navigation
- Explains the need to pay continuous attention to all the running parameters of machinery and to what tasks are being carried out by other personnel concerned
- Explains the need to be well-versed in structure of the engine-room including evacuation route and installations/equipment for emergency
- States that arrangements of fire-extinguishing installations should be clearly understood including sorts and number of fire-extinguisher in accordance with types of ship
- States immediate actions to be taken in the event of accidents such as fire, a person overboard, oil spill and flooded, emphasizing that the appropriate immediate actions minimize damage
- Explains necessary measures to contain oil spreading in the event of oil spill including communicating information/report, preparation of the dedicated apparatus against oil spill, plugging of scupper pipes and stopping oil systems

1.1.4 ENGINE-ROOM RESOURCE MANAGEMENT (ERM) (7 hours) R1

Textbooks:

Teaching aids: A1, A3, V4, V6, V13

**STCW Code Ch □
Section A-VIII/2
Part 3 Para 8**

Required performance:

- Explains ERM principles based on Bridge Resource Management (BRM)/ERM principles described in STCW Code Ch VIII Section A-VIII/2, Part 3 paragraph 8
- Explains ERM in terms of maintaining the safe engineering watch including why ERM is necessary
- Explains the resources considered to be included in ERM
- Explains the resource management in a specific manner taking examples such as personnel management, information management and management of installations/equipment
- Explains what is necessary to practice ERM
- Explains what is meant by the following in practicing ERM
 - allocation, assignment and prioritization of the resources
 - effective communication
 - assertiveness and leadership
 - obtaining and maintaining situational awareness
 - consideration of team experience

COMPETENCE 1.2	Use English in Written and Oral Form	IMO Reference
----------------	--------------------------------------	---------------

TRAINING OUTCOME

Demonstrates a knowledge and understanding of:

STCW Code
Section A-III/1

**1.2.1 THE ENGLISH LANGUAGE TO ENABLE THE OFFICER
TO PERFORM ENGINEERING DUTIES AND TO USE
ENGINEERING PUBLICATIONS**

**IMO Model
Course, in
production**

COMPETENCE 1.2	Use English in Written and Oral Form	IMO Reference
----------------	--------------------------------------	---------------

**1.2.1 THE ENGLISH LANGUAGE TO ENABLE THE OFFICER
TO PERFORM ENGINEERING DUTIES AND TO USE
ENGINEERING PUBLICATIONS (20 hours)**

**IMO Model
Course, in
production**

Textbooks:T71
Teaching aids: A4

Required performance:

- Use English in written and oral form to:
 - perform the officer's duties;
 - use general maritime vocabulary;
 - use marine technical terminology;
 - use manufacturers' manuals;
 - use shipboard drawings;
 - use other engineering publications.

R1

COMPETENCE 1.3	Use internal communication systems	IMO Reference
----------------	------------------------------------	---------------

TRAINING OUTCOME

Demonstrates a knowledge and understanding of:

STCW Code
Section A-III/1

**1.3.1 OPERATION OF ALL INTERNAL COMMUNICATION SYSTEMS
ON BOARD**

COMPETENCE 1.3	Use internal communication systems	IMO Reference
----------------	------------------------------------	---------------

TRAINING OUTCOME

**1.3.1 OPERATION OF ALL INTERNAL COMMUNICATION SYSTEMS
ON BOARD
(5 hours)** STCW Code
Section A-III/1
...

Textbooks:

Teaching aids: A3

STCW Code
Section A-III/1

Required performance:

- States the importance of:
 - communicating effectively in all circumstances;
 - orders, instructions, reports and exchange of information being clear, accurate and concise;
 - using accepted marine terminology, and proper methods are employed;
 - chief or second Engineer being kept informed as required; and
 - the bridge being informed and consulted as required.

COMPETENCE 1.4	Operate Main and Auxiliary Machinery and Associated Control Systems	IMO Reference
----------------	---------------------------------------------------------------------	---------------

TRAINING OUTCOME

Demonstrates a knowledge and understanding of:

STCW Code
Section A-III/1

- 1.4.1 BASIC CONSTRUCTION AND OPERATION PRINCIPLES OF MACHINERY SYSTEMS**
- 1.4.2 SAFETY AND EMERGENCY PROCEDURES FOR OPERATION OF PROPULSION PLANT MACHINERY INCLUDING CONTROL SYSTEMS**
- 1.4.3 PREPARATION, OPERATION, FAULT DETECTION AND NECESSARY MEASURES TO PREVENT DAMAGE FOR THE FOLLOWING MACHINERY ITEMS AND CONTROL SYSTEMS**

COMPETENCE 1.4	Operate Main and Auxiliary Machinery and Associated Control Systems	IMO Reference
----------------	---------------------------------------------------------------------	---------------

1.4.1 BASIC CONSTRUCTION AND OPERATION PRINCIPLES OF MACHINERY SYSTEMS (405 hours)

Textbooks: T24, T26, T35, T50
Teaching aids: A1, A2, A3, V8, V9, V10, V11, V14

Required performance:

1.4.1.1 Marine Diesel Engine (100 hours)

1) Heat-engine cycle (20 hours)

R1

- Defines "heat-engine cycle" as a number of thermodynamic processes arranged in a given sequence, and repeated over constant intervals of time
- States that real practical cycles are based on "ideal" theoretical cycles
- States that most ideal cycles involve the following thermodynamic processes:
 - heating or cooling, at constant pressure
 - heating or cooling, at constant volume
 - adiabatic compression or expansion
- States that the cycle of thermodynamic processes (or operations) is called out on a "working fluid"
- States that ideally the working fluid is "perfect", with its physical properties and structure remaining constant throughout the cycle
- States that working fluids used in practical engines change during the cycle of processes
- States that the function of a heat-engine cycle is to produce the maximum possible output of useful work (W) from a given quantity of energy supplied to the working fluid
- States that, in the majority of practical heat-engine cycles, the energy input is obtained from the energy released by the combustion of a fuel with air
- States that the "efficiency" of the cycle is measured by the energy output obtained per unit of energy supplied to the working fluid
- States that, in the "ideal" case, the energy output will be the difference between the energy supplied during the cycle (Q_1) and the energy remaining and rejected at the end of the cycle (Q_2)
- Deduces from the above objective that ideally the output energy is the difference between the energy supplied and the energy rejected, i.e. $W = Q_1 - Q_2$
- Deduces from the above objective that the cycle efficiency is given by the ratio:
$$\frac{\text{Energy output}}{\text{Energy input}} = \frac{W}{Q_1} = \frac{\text{Energy supplied} - \text{Energy rejected}}{\text{Energy supplied}} = \frac{Q_1 - Q_2}{Q_1}$$
- Solves simple numerical problems related to the equation in the above objective

2) Ideal-gas cycle (15 hours)

R1

- Defines ideal-gas cycle as those which use a perfect (or ideal) gaseous working fluid
- Defines the following cycles as a sketch on a plane of pressure-volume:
 - Otto cycle
 - Diesel cycle
 - Dual cycle
 - Joule cycle
- indicating where the thermodynamic processes given in the above objective have been used in each cycle
- Names the practical engines whose cycle is modelled on the cycles listed in the above objective as:

- Otto, internal-combustion reciprocating engine, using gas or petrol as a fuel; ignition of fuel is by spark
- Diesel, compression-ignition reciprocating engine, using diesel or heavier fuel oil; ignition is by transfer of heat energy from compressed air
- Dual, modern development of the diesel cycle
- Joule, rotary turbine, using gaseous or light to medium fuels ("gas turbine")
- Explains the meaning of "single-and double-acting" as applied to reciprocating engines
- Describes the processes which take place in each stroke of the two-stroke and four-stroke cycles in diesel and petrol engines
- Lists the usual maximum temperatures and pressures for the cycles listed in the above objective
- Sketches a diagram showing typical crank angles at which air and exhaust valves or ports open and close and the periods of air inlet, compression, combustion, expansion and exhaust in the above objective

3) Diesel engine fuel atomization and combustion (20 hours) R1

- Describes the combustion process in a boiler or an engine cylinder
- Describes the chemical reaction in combustion as being between combustible materials such as hydrocarbon on fuels and the oxygen contained in atmospheric air
- States that, as a result of combustion, heat energy become available, enabling thermodynamic operations to be carried out
- States that the heat released during the combustion of a unit of a substance is termed calorific value (CV)
- States that calorific values for fuels are usually stated with respect to unit mass in the case of solid and liquid fuels and unit volume in the case of gaseous fuels
- States that the main combustible elements in marine fuels are carbon, hydrogen and sulphur
- States the appropriate calorific values of the elements given in the above objective
- States that sulphur is usually present in marine fuels
- States that the salts of sodium and vanadium are usually present in marine fuels
- States that sulphur, although combustible, is an undesirable element in a fuel
- States that sodium and vanadium are also undesirable elements in a fuel
- States typical percentages of carbon, hydrogen and sulphur for
 - fuel oil for a steam boiler
 - marine diesel fuel
- States typical calorific values for marine fuels
- States the average proportions, by percentage, of oxygen and nitrogen in atmospheric air
- Sketches a section through a typical injector nozzle assembly
- Explains how atomization is produced by the injector nozzle
- Explains why swirl and penetration are important to the ignition and combustion of the fuel/air mixture
- Describes the care necessary with injector nozzle holes

4) Engine types (10 hours) R1

- States that marine diesel engines are normally described in broad categories by the bore of their cylinders and their rotational speed
- States that large-bore engines are normally fitted with piston rods and crossheads
- States that smaller diesel engines normally have trunk pistons and gudgeon pin in the place of piston rods and crossheads
- States that large-bore engines are normally directly connected to the propeller and therefore rotated at low speed
- States that other diesel engines may run at medium speed or high speed, depending upon their duty

- States that medium-speed and high-speed engines are often used as direct drives for generation of electrical power
- States that medium-speed engines (and occasionally high-speed engines) are used, through some form of speed reduction, as main propulsion engines.
- States the approximate speed ranges related to the following engines:
 - low-speed
 - medium-speed
 - high-speed

5) Engine principles (15 hours)

R1

- Sketches typical indicator diagrams for:
 - a two-stroke engine
 - a four-stroke engine
- Explains the problems of obtaining indicator diagrams from slow-speed, medium-speed and high-speed engines
- States that peak pressures are sometimes measured which give an indication of engine power and performance
- Develops the expression: $work = pressure \times volume$, to produce an expression for the power of a diesel engine in terms of m.e.p., number of cylinders, length of stroke, diameter of piston and r.p.m.
- Calculates indicated power, using given dimensions, r.p.m., m.e.p. and the expression developed in the above objective
- States typical compressions and maximum pressures for slow-, medium- and high-speed engines
- Explains the reasons for supercharging, giving typical supercharge pressures
- Using the equation $PV = mRT$, shows the effect of varying P and T in a diesel-engine cylinder
- Sketches and labels a diagrammatic arrangement of a supercharging system
- Explains why high pressures are required for the injection of fuel into the cylinder
- Describes the essential features of a hydraulic fuel injector
- States, as approximate percentages or fractions, a simple distribution of energy obtained from the fuel into:
 - output as useful work
 - heat to the cooling media
 - energy retained in the exhaust gases
 - energy absorbed in engine friction
 - energy lost through radiation
 - states, for a marine propulsion diesel engine, typical values of:
 - brake thermal efficiency
 - mechanical efficiency
 - fuel consumption in kg per kW hour

6) Basic Construction (20 hours)

a) Large-bore (two-stroke) engine details (10 hours)

R1

- Describes with the aid of a simple single line sketch, naming the material of manufacture, the assembled construction of the principal components of a diesel engine, including:
 - the bedplate
 - a main bearing
 - an 'A' frame and entablature
 - guides
 - a liner
 - a cooling-water jacket
 - a cylinder head

- a diaphragm
- a turbocharger
- the scavenge trunk
- an air cooler
- the crankshaft
- a connecting rod
- a crosshead
- a piston
- a bottom end bearing
- a top end bearing
- the camshaft
- a push rod
- a rocker
- an exhaust valve or port
- an air-inlet port
- the chain or gear train driving the camshaft
- Sketches a section through a piston, showing the cooling arrangements
- Sketches a section through an engine bedplate, showing the longitudinal and transverse girders, the main-bearing and tie-bolt housings
- Describes, with the aid of simple sketches, the following valves, showing principle parts, materials and method of operation:
 - exhaust valve
 - cylinder lubricator
 - fuel valve
 - cylinder relief valve
 - air-starting valve
 - crankcase relief valve
 - jerk fuel pumpincluding the pressures at which the two relief valves operate
- With the aid of engine manufacturers' manuals, defines specified work clearances of all bearing and sliding surfaces and interference fits, where applicable
- Describes, with the aid of diagrams, the distribution of lubricating oil to the guides, top-end, bottom-end and main bearings when pistons are oil-cooled and when water-cooled

b) Medium-speed and high-speed (four-stroke) diesel engines (10 hours) R1

- Lists the services for which auxiliary diesel engines are used
- Name the materials used in the manufacture of the listed items, then describe, with the aid of sketches, the assembled construction of these items:
 - the bedplate
 - a cylinder block
 - a cylinder jacket
 - a cylinder liner
 - a cylinder head
 - the exhaust gas manifold
 - the air-inlet manifold
 - the air cooler
 - the engine crankcase
 - a bearing housing and shell
 - the lubrication-oil sump
 - a piston
 - a connecting rod
 - a gudgeon pin
 - the crankshaft

- the camshaft and chain
- the push rods
- the fuel injector
- the air inlet and exhaust valves and rockers
- Describes in simple terms the principal features of a typical "V"-type medium-speed diesel engine
- Sketches a diagrammatic arrangement of a propeller drive from two medium-speed engines
- Sketches typical timing diagrams for medium-speed and high-speed diesel engines
- Describes a simple governor to maintain normal running speed under conditions of variable load
- Describes, with the aid of diagrams, a lubrication and piston-cooling system for a medium-speed diesel engine
- Identifies that the power starting of an auxiliary diesel engine can be pneumatic, hydraulic or electrical
- Explains why it is important to maintain the lubricating oil and fuel filters clean and in good condition
- Uses engine builders' manuals to obtain working clearances specified by the instructor
- Describes how the diesel engine of an emergency generator is started
- States the normal intervals between checking and testing the emergency generating engine

1.4.1.2 Marine Steam Turbine (50 hours)

1) Rankine cycle (20 hours)

R1

- States that the Rankine cycle is the ideal cycle where the working fluid is used in both liquid and vapour phases, such as:
 - steam power plant
 - refrigeration plant
- Describes the four main components of steam plant as:
 - the steam boiler, which produces superheated steam from feed water, the required energy being supplied from the combustion of a fuel in air
 - the turbine(s), which adiabatically expand the high-pressure superheated steam to obtain useful output work (W)
 - the condenser, which receives the low-pressure exhaust steam from the turbine to cool it and condense it to water
 - the feed pump, which raises the pressure of the condensate to the boiler pressure and pumps it back into the boiler
- States the Rankine cycle efficiency as the ratio:
Energy derived from the cycle as useful work
Energy supplied to the cycle
- States that the output energy of the cycle is the turbine work (W)
- States that the turbine work (W) is defined as the difference in energy contained in the superheated steam entering the turbine and the energy contained in the exhaust steam leaving the turbine
- States that the energy input of the cycle is the energy transferred from the fuel during combustion in the boiler
- States that because the working fluid is in both the liquid and vapour phases during the cycle, energy levels and other properties for the working fluid must be obtained from tables of thermodynamic properties
- Draws and labels a simple line diagram of a steam plant, using "blocks" for the four main components and arrows to indicate flow of the working fluid and indicating energy values at important points in the cycle
- Solves simple numerical problems related to the above objectives

2) Basic construction (10 hours)

- Names the materials used in the manufacture of the listed items, then describe, with the aid of sketches, the assembled construction of these items:
 - high pressure turbine casing
 - low pressure turbine casing
 - astern turbine casing
 - low pressure turbine exhaust casing
 - high pressure turbine rotor
 - low pressure turbine rotor
 - receiver pipe
 - reduction gear
 - wheels
 - pinions
 - main condenser
 - gland condenser gland packing steam leak-off reservoir
 - gland packing steam reservoir
 - gland packing steam leak-off reservoir
 - gland packings
 - gland steam make-up valve, gland steam spill valve
 - manoeuvring valve
 - astern guardian valve
 - flexible coupling
 - thrust bearing
 - labyrinth packings
 - nozzles
 - blades (moving blade, stationary blade)
 - shroud
- States the feature of impulse turbine
- States the feature of reaction turbine
- Sketches types of turbine plant arrangement
 - bleeder turbine (extraction turbine)
 - regenerative turbine
 - reheat turbine

3) Operation principles (20 hours)

- Explains why main condenser is kept in vacuum
- Explains how to keep main condenser in vacuum
- Describes the importance of draining inside turbine casing
- Describes, with the aids of a sketch/computer aided drawing, function of gland packing steam
- Explains the function of manoeuvring valve
- Explains the role of extraction steam
- Describes that gland steam pressure is controlled by make-up valve and spill valve
- Describes how to keep the hotwell level of condenser
- Explains spinning operation
- Explains the meaning of throttle governing and nozzle governing, which is the way of control of turbine output
- Explains meaning of auto-spinning system
- States that the main turbines are provided with a satisfactory emergency supply of lubricating oil, which will come into use automatically in case of failure of lubricating oil system

1.4.1.3 Marine Gas Turbine (15 hours)

1) Operation principles (8 hours)

- Explains how a gas turbine is used for
- Describes the feature of a gas turbine
- Describes the operation principles in terms of four processes, compression, combustion (heating), expansion and exhaust
- Compares a gas turbine with a steam turbine in terms of advantages and disadvantages
- Describes the types of gas turbines

2) Basic construction (7 hours)

- Using visual aids, describes the three main components of gas turbine as:
 - compressor
 - combustion chamber
 - turbine
- Describes the types of compressors and their features
- Describes the types of combustion chambers and their features
- Describes the types of turbine and their features
- Lists the attached equipment and explains their feature and functions in simple terms

1.4.1.4 Marine Boiler (40 hours)

1) Steam boiler fuel atomization and combustion (12 hours)

R1, R3

- States that the elements carbon and hydrogen combine chemically with oxygen during combustion to form the gaseous products carbon dioxide and water vapour
- Explains the part played by nitrogen in the combustion process
- States that, to ensure that the combustion process is as complete as possible, excess air is normally supplied
- States that the excess of air must be kept to a minimum, consistent with good combustion
- States that either the percentage of carbon dioxide or the percentage of oxygen in the exhaust gas should be continuously recorded
- States that although excess air is supplied, there may be some incomplete combustion of carbon to carbon monoxide (CO)
- States that in practice the products of combustion are normally a gaseous mixture of carbon dioxide, sulphur dioxide, water-vapour, possibly carbon monoxide and an ash, possibly containing sodium and vanadium
- States that poor combustion creates smoke, which pollutes the atmosphere and wastes fuel and reduces the efficiency of the engine or boiler
- States that the production of smoke may lead to prosecution
- Explains why the proportion of CO₂ or O₂ in exhaust gases provides an indication of combustion efficiency
- Describes briefly the instruments available to indicate and record the percentage of CO₂ and O₂ in exhaust gas
- States the ranges of percentages of CO₂ which indicate:
 - good combustion
 - poor combustion
 - bad combustion
- Explains the importance of atomization when it is required to mix a liquid fuel with air prior to combustion
- Explains why the viscosity of a fuel is important in its atomization
- Describes how the viscosity of a liquid fuel can be controlled by varying its temperature
- States the theoretical air/fuel ratio for a typical boiler fuel
- States the actual air/fuel ratio, allowing for normal excess air, in:
 - the furnace of a steam boiler
 - the cylinder of a diesel engine

- States that if sulphur dioxide contacts a low-temperature surface, sulphuric acid will be produced, which will cause corrosion
- Explains how the effect of the above objective can be minimized
- Describes the effect of ash on atomizing equipment
- Sketches a section through the nozzle assembly of a pressure-jet burner
- States that in the above objective atomization is produced by the fuel, at high pressure, passing through a small orifice in the burner nozzle
- Describes the attention required by burner atomizer tips
- Describes, with a single line diagram, a combustion air register, identifying:
 - swirl vanes
 - the quarl
 - the flame stabilizer
 - air-flow control valves
 - the burner
- States typical values of the pressure drop and of the velocity of combustion air in the register
- Explains why the thorough and rapid mixing of atomized fuel and combustion air is important
- Describes furnace conditions which indicate good combustion
- Describes, with the aid of sketches, how pressure-jet, steam-jet and rotary-cup burners atomize fuel and promote adequate fuel/air mix ratio

2) Marine boiler fundamentals (8 hours)

R1

- Describes, with the aid of diagrams, an auxiliary boiler steam system together with identifying the services supplied by steam
- States typical pressures of steam produced in auxiliary boilers and average system supply pressures
- States that auxiliary steam boilers range from simple fire-tube boilers to self-contained fully automated package units
- Explains simply and briefly, with the aid of diagrams, the principal differences between a fire-tube boiler, a water-tube boiler and a packaged boiler

3) Marine boiler construction (10 hours)

R1

- Describes the material commonly used for construction in a fire-tube boiler
- Describes, with the aid of sketches, the general constructional details of a fire-tube boiler, showing how the parts are connected to form a complete structure
- States that, for pressure vessels:
 - shells of cylindrical form give a higher strength/weight ratio than other shapes
 - the cylindrical shell can be sited vertically or horizontally
 - dished or spherical end-plates give a higher strength than flat end-plates of similar thickness
 - all flat surfaces must be properly stayed to resist deformation
 - stays can have the form of solid bars, thick tubes or plate girders
 - corrugated furnaces provide higher strength and flexibility than plain furnaces of similar thickness
- States why boiler is usually installed on board diesel engine ships
- Explains and outlines a boiler system listing associated systems including their components
- Explains the relationship between a boiler and exhaust gas economizer
- Explains ignition system including the function of burner control
- Explains feed water system including the function of feed water control
- Explains steam temperature control system usually used for main boiler
- States what is meant by ABC and ACC
- Describes how a tube is expanded into a tube plate
- Describes the principles of construction, operation and control of a packaged boiler

4) Marine boiler mountings and steam distribution (10 hours)

R1

- Identifies the following boiler fittings and position on boiler shell (supply shell diagram for fitting to be married/drawn and identified):
 - main steam outlet (or "stop") valve
 - auxiliary steam stop valve
 - safety valves and easing gear
 - water level gauges
 - feed inlet valve
 - blow-down valve
 - scumming valve
 - soot blowers
 - connections for pressure gauges
 - air release valve
 - sampling valve
- Explains the importance of boiler mounted valves
- Identifies the following internal boiler fitting and internal position within boiler shell:
 - feedwater distribution unit
 - scumming pan
 - blow-down dip pipe
- Explains the purpose of the valves and fittings listed in the above objectives, comparing the differences, where applicable, between water-tube and fire-tube boilers
- Explains the purpose of a reducing valve
- Describes the operation of a reducing valve, using a single line sketch
- Explains how steam pipes are supported
- Explains how expansion and contraction are allowed for in steam pipes
- Describes the different methods of joining lengths of a steam pipe
- Explains the purpose of drains and steam traps
- Describes the operation of steam traps
- Describes the procedure for warming through a steam line and explains the cause, in simple terms, of water hammer and how water hammer can be avoided
- Explains the outline of steam supply system including its components/installations
- Describes the means used to minimize the possibility of oil contaminating the boiler feed water

1.4.1.5 Shafting Installations and Propeller (20 hours)

1) Shafting installations (10 hours)

- Describes the following installations/equipment constructing shafting:
 - propeller
 - rope guard
 - stern tube
 - stern tube bearing
 - shaft seal
 - propeller shaft
 - intermediate shaft
 - aft bearing
 - plumber block
 - thrust bearing
- Describes the details of oil shaft seal and stern tube bearing including their components
- Describes the details of thrust bearing

2) Propellers (10 hours)

- Describes various types of propellers and their features
- Describes structure and materials for propellers
- Defines the following parameters of propeller:

- diameter
- pitch
- pitch ratio
- boss ratio
- pressure side
- suction side
- leading edge
- following edge
- blade section
- blade rake
- Explains briefly how propellers fit on propeller shafts
- Describes a highly -skewed (skew back) propeller and its advantages
- Describes a controllable pitch propeller (CCP) and its mechanism of changing blade angle
- States the advantages and disadvantages of a controllable pitch propeller in comparison with fixed pitch propeller (FPP)
- Defines the cavitation of propellers and explains its generating mechanism
- Defines the propeller singing and explains its generating mechanism and preventive measures

1.4.1.6 Other Auxiliaries (115 hours)

1) Various pumps (20 hours)

a) Principles (5 hour)

R1

- States that the function of a pump is to transfer fluid between two given points
- Lists the losses of head in a pumping system
- States that the viscosity of the fluid to be pumped must be within the range specified in the pump design
- States that permission should be obtained before any fluids are moved which might affect the stability of the ship and cause pollution overboard

b) Types of pump (15 hours)

R1

- Names the types of pump generally used on ships and the purposes for which they are normally used
- Explains the basic action of a displacement pump
- Explains the necessity for a relief valve to be fitted in the discharge of any displacement pump
- States that when a pump is handling oil or other hazardous material any discharge from the relief valve must be contained within the pumping system
- Describes, with the aid of diagrams, how a reciprocating displacement pump works
- Explains the purpose of an air vessel fitted to the discharge
- Describes the characteristics of a reciprocating pump, referring to:
 - suction lift
 - priming
 - discharge pressure
 - vapour, or gas, in the fluid being pumped
- Explains the principle of rotary displacement pumps
- Sketches a single line diagram to show the principle parts of:
 - a gear pump
 - a rotary vane pump
 - a screw-displacement pump
- Describes the principles of operation of an axial-flow pump
- Describes the type of duty best suited to an axial-flow pump
- Explains the principles of a centrifugal pump, referring of the purpose of:
 - the impeller
 - the diffuser or volute

- Makes a single line sketch of a vertical single-entry centrifugal pump
- Explains what is meant by a 'single-entry' and a 'double entry' impeller
- Describes the arrangement of a vertical multi-stage single-entry centrifugal
- Explains the purpose of a diffuser
- Describes the characteristics of a centrifugal pump, referring to:
 - suction lift
 - priming
 - discharge pressure
 - vapour or gas in the fluid being pumped
- Explains why and when priming and/or air extraction is necessary and makes single line sketches of:
 - a reciprocating air pump
 - a water-ring air pump
- Makes a single line sketch of a central priming system and explains its advantage
- Explains the principle of an ejector

2) Refrigeration (40 hours)

a) Marine refrigeration cycle (20 hours)

R1

- States that a refrigeration cycle operates on a reversed heat-engine cycle
- Describes the working fluids for this cycle as "refrigerants"
- States that because working fluids are used in both the liquid and vapour phases during the cycle, energy levels and other properties for the working fluid must be obtained from tables of thermodynamic properties
- Describes the four main components of the plant as:
 - the evaporator, in which the low-pressure refrigerant enters as a cold liquid and is evaporated to a cold low-pressure vapour
 - the compressor, in which the low-pressure cold vapour is compressed to a high-pressure superheated vapour
 - the condenser, in which the hot-high-pressure vapour is cooled and condensed to a cool liquid
- The expansion valve, where the cool high-pressure liquid is throttled and expanded to a low-pressure cold liquid
- States that the energy required to evaporate the low-pressure liquid refrigerant to a low-pressure vapour at constant low temperature is transferred from the refrigerated chambers, either directly or through a secondary coolant such as brine
- States that the transfer of energy from the refrigerated chamber is that which produces and maintains its low temperature
- States that the refrigeration plant performance is measured by the quantity of energy extracted from the refrigerated chambers per unit energy supplied in compressor work
- States that the input energy from the compressor is the difference between values of the refrigerant energy at the inlet to and at the exit from the compressor
- Using $\frac{\text{Energy extracted in the evaporator}}{\text{Energy input from compressor}}$, derived from the above objectives calculates the performance of a refrigerator
- Draws and labels a line diagram of a refrigeration plant, using "blocks" for the main components and arrows to indicate flow of the working fluid and indicating the energy values at important points of the cycle
- Applies simple numerical calculations related to, and making use of the above objectives
- Lists the refrigerants commonly used in marine refrigeration systems

b) Principles of refrigeration (8 hours)

R1

- Explains, in simple terms, the difference between refrigeration, air conditioning and ventilation
- States that marine refrigerating systems operate on a reversed Rankine cycle, which is

- also termed the vapour-compression cycle
- Sketches a single line and block diagram of a refrigeration system, system components and arrows to indicate flow of refrigerant, showing the following components:
 - compressor
 - condenser
 - regulator valve and controlling sensor
 - evaporator
 - oil separator
 - drier
 - Shows on the diagram in the above objective the part of the system where the following processes take place:
 - removal of superheat
 - condensation
 - throttling
 - evaporation
 - compression
 - expansion
 - charging
 - Describes the requirements of a primary refrigerant
 - Names common primary refrigerants currently specified under IMO recommendation (ozone protection)
 - Describes the purpose of a secondary refrigerant
 - Names common secondary refrigerants

c) Refrigerating compressors (2 hour)

R1

- States the types of compressor in common use
- Describes in simple terms the applications of the types of compressor in the above objective
- States that cylinder blocks of a reciprocating compressor can be either in line or in a vee
- Describes, with aid of simple sketches, a rotary gland seal
- Describes how excessive pressure in the cylinder is relieved

d) Refrigerating system components (4 hours)

R1

- States the function of the expansion valve
- Describes how the expansion valve is controlled
- Sketches an expansion valve in section as a single line diagram
- Describes briefly how an oil separator works
- States the function of a liquid receiver
- Describes how the system can be controlled automatically, using the temperature of the cold room
- Describes in simple terms a condenser
- Describes in simple terms an evaporator

e) Refrigerating system brines (4 hours)

- Describes the composition of a brine
- Explains how the density of a brine is varied to suit the temperature of operation
- Determines the density of brine samples
- States that a brine density should be sufficient to give a freezing temperature below the lowest temperature required
- States that a brine should be maintained with an alkalinity between pH 8 and 9 to minimize corrosion
- Determines the pH value of brine samples
- Explains the precautions to be taken if a brine has to be made with sodium chloride
- Describes the process of making a brine

f) Cold storage spaces (2 hour)

- Describes the principles of insulation of storage spaces
- States that range of temperature for spaces containing:
 - frozen meat and fish
 - vegetables
 - lobby

3) Air conditioning and ventilation systems (5 hours)

- Sketches a single line and block diagram of an air conditioning system, system components and arrows to indicate flow of refrigeration, showing the following components:
 - fan
 - thermostat
 - fresh air dumper
 - return air dumper
- States how to control temperature and humidity in the air conditioning system

4) Heat Exchangers (10 hours)

R1

- States that marine heat exchangers are normally of the surface heat-transfer type and that seawater is used for cooling and condensing steam for heating
- Describes surface heat transfer, referring to the relative direction of flow of fluid
- Defines 'contact heat transfer' as the heat flow between fluids initially at different temperatures when they are mixed together
- Sketches the principle of construction of the following surface heat-exchangers:
 - shell and tube
 - flat plate type
- Explains the meaning of single-pass, two-pass, etc
- Lists the types of heat exchangers used for the following:
 - lubricating-oil coolers
 - fuel-oil heaters
 - fresh-water coolers
 - compressed-air coolers
 - fresh-water heaters
 - steam condensers
 - seawater evaporating and distilling plant
 - seawater heaters
 - evaporators and condensers in refrigerators
- States the materials used for the shell, tubes and tube plates of heat exchangers
- Explains how:
 - differential expansion is allowed for
 - an effective seal is maintained between the fluids
 - leakage is detected
- Explains how temperature control is achieved in coolers
- Describes the effect of partially closing the cooling-water inlet valve
- Explains the effect of entrained air in cooling water and how it is removed

5) Evaporators and distillers (15 hours)

R1

- Explains why 'fresh water' may have to be produced from seawater
- Lists the purposes for which the water might be used
- Explains the effect that distillation has on the dissolved solids in seawater
- States that evaporators and distillers are pressure vessels and as such must conform to approved standards for materials, fittings and construction

- States that there are two main methods of obtaining vapour from seawater:
 - by direct boiling, using boiling water evaporators
 - by the evolution of vapour when the seawater is 'supersaturated', using flash evaporators
- Describes in simple terms, using line sketches, the construction of a shell and coil evaporator, naming the materials of the principal parts
- Lists the mountings fitted to a simple shell and coil evaporator
- Explains why a reducing orifice is fitted in the steam supply line of such an evaporator
- States that the heat transfer can be obtained from:
 - a supply of steam or other hot fluid passing through coils
 - tubes which are immersed in the seawater or
 - an electrical element immersed in the seawater
- Explains why low-pressure evaporators are used
- Explains what is meant by single-effect and by double-effect evaporation

(Flash Evaporators)

- Explains the principle of flash evaporation
- States that flash evaporators can use a number of stages, with seawater feed passing through each stage in succession
- Describes, with the aid of a simple sketch, a two-stage flash evaporator
- Explains the principle of operation of the evaporator in the above objective

(Multiple-effect Evaporation)

- States that shell and coil evaporators can be connected in series, with the vapour produced in the first unit being used as the heating fluid in the next unit, the seawater passing through each unit in turn
- States that production of vapour in the second and successive units occurs partly by boiling and partly by flash evaporation
- States that such a system is termed 'multiple effect'
- States that multiple-effect evaporation produces an increased quantity of fresh water compared to a single evaporator using a similar input of heat
- Describes, with the aid of a single line sketch, the arrangement of a two-stage Flash-evaporation plant

6) Air compressor and system principles (15 hours)

a) Air Compressors (10 hours)

R1

- Describes an air compressor as a pump which takes air from the atmosphere and, with an input of energy, compresses it in one or more states to a smaller volume with higher pressure and temperature
- Explains the reason for cooling the air, during and after the compression
- States that the compressed air is stored in steel reservoirs until required for some purpose, such as starting a diesel engine
- States that, during the compression process, the relationship: $PV^n = a$ constant will apply
- States that air can be treated as an ideal gas and that the relationship :
 $\frac{PV}{T} = a$ constant
will also apply
- States that for the air storage tank the relationship: $PV = mRT$ will apply, where:
 - m = mass of air stored in the tank (kg)
 - R = specific gas constant for air (=8314 J/kg/K)
 - T = temperature of air, in kelvin units
 - P = air pressure, in Newtons per square metre
 - V = volume of reservoir tank, in cubic metres

- Solves simple numerical problems related to the above objectives
- b) Air compressors and system principles (5 hours) R1**
 - Lists shipboard uses of compressed air
 - States the common pressure limit of single-stage compressors
 - States that, in order to restrict the rise of air temperature during compression, the air is cooled by circulating water around the cylinder
 - States that air compressor can be single-stage or multi-stage reciprocating or rotary machines
 - Describes the compression processes in a two-stage reciprocating compressor
 - Draws a line diagram of a two-stage air compressor, indicating stage air pressures and temperatures
 - Explains why intercoolers and after-coolers are used
- 7) Purifier and fuel oil treatment (10 hours)**
 - Describes the following with the aid of sketches:
 - bowl
 - operating water valve
 - gravity disk
 - valve cylinder
 - plug screw
 - disk
 - States principles of purifying to eliminate water or dirt particles from oil
 - Explains why fuel oil treatment is necessary
 - Explains in simple terms, the purification by using gravity force and filters, and centrifugal separation
 - Describes the following types of filter, which are used in fuel oil lines
 - mesh/gauze elements
 - edge-type packs
 - magnetic elements
 - fibre assemblies
 - Explains how the force of gravity is used to separate out liquids and solids of different densities
 - Describes the operation principles of an oil purifier
 - Explains why the use of centrifugal separation is much faster and more effective than gravity in the separation process
 - Describes, with the aid of simple sketches, a bowl separator and a tube separator, showing the main components and the principal differences between the two
 - States the rotation speeds used in the equipment described in the above objective

1.4.1.7 Steering Gear (20 hours)

- 1) Steering gear principles (10 hours) R1**
 - States that the gear is vital to the safety of a ship; it must function correctly and be properly serviced and maintained
 - States that there must be two independent means of steering
 - States that alternative control of the steering gear must be provided in the steering gear compartment
 - Draws a line and block diagram, to represent the major components, of a steering system, showing:
 - the steering-wheel transmitter-located in the bridge space
 - the rudder-control receiver unit -located aft in the steering compartment
 - the systems conveying the transmitter signal to the receiver
 - the power system which moves the rudder
 - the rudder-control feedback to the system
 - States that the function of the receiver is to act on the signal, from the transmitter and,

- through a control element, to operate the rudder power system
 - States that the transmitter and receiver system can be hydraulic or electrical
 - States that the rudder power system can be hydraulic or electrical
 - Identifies the particular requirements of oil tankers
- 2) Steering gear electrical control (2 hour)**
- Describes the principles of operation of an electrical control system
- 3) Hydraulic power-operated rudder systems (4 hours)**
- Explains that the systems can be principally cylinders and rams or a radial-vane motor
 - Sketches, using lines and block diagrams, the system of cylinders and rams, showing how, with a pair of rams in line and two rams in parallel, hydraulic pressure actuates the rudder through a crosshead or trunnion and tiller-arm assembly
 - States that, in a radial-vane-type system, hydraulic pressure acts on radial vanes attached to the rudder stock, this producing movement of the rudder
 - Describes normal operation of rudder drive pumps and system, indicating which valves are open and which are closed
 - States the materials normally used in the main components in the above objectives
- 4) Hydraulic power rotary pumps (4 hours)**
- States that a rotary positive-displacement pump is used to obtain displacement of fluid and produce movement of the rudder
 - States that the pump in the above objective is driven by an electric motor
 - Describes the principle of operation of a radial cylinder pump
 - Describes the principle of operation of a swash-plate pump
 - Describes how the pumping action is controlled:
 - by linkage to the telemotor receiver and
 - by linkage to the rudder, for feedback control
 - Describes, with the aid of single line sketch, how the pump is controlled to move the rudder from one position to another
 - States that the fluid in the system must be the correct mineral-base oil which is clean and free of moisture
 - Explains how shocks to the system from wave action on the rudder are absorbed
- 1.4.1.8 Automatic Control Systems (20 hours)**
- Names and describes each component constructing the following control methodologies:
 - ON-OFF control
 - sequential control
 - PID control
 - program control
 - Describes what control methodologies can be applied to which control systems taking examples such as automatic motor start/stop for ON-OFF control, automatic generator start/stop for sequential control, level/temperature/pressure control for PID control and main engine speed multiplication/reducing program for program control
 - Describes in simple words, the construction and functions of each component for control systems
 - Describes operation principles of each component constructing automatic control systems taking examples such as:
 - pressure switch
 - temperature switch
 - resistance bulb
 - electric-pneumatic converter
 - electromechanical transducer
 - valve positioner
 - control valve

- relay
- pneumatic/electronic PID controller

1.4.1.9 Fluid Flow and Characteristics of Major Systems (15 hours)

- Describes fluid flows of:
 - fuel oil
 - lubricating oil
 - cooling fresh water
 - cooling sea watersystems in the diesel engine propulsion plant
- Describes fluid flows of:
 - main steam
 - condensate water
 - and feed water
 - lubricating oilsystems in the steam turbine propulsion plant
- Describes what sorts of fittings are used to construct each plant system taking examples such as various types of valves, pipings, pressure regulator and the like
- Describes characteristics appeared in the each piping system taking examples such as supplementary devices/pipings, pipe colouring and location of equipment/installations
- Conduct a work shop meeting giving an opportunities to the trainees to present their research activities on construction of piping systems
- Describes the means by which lengths of pipe are joined together, naming the materials used to seal joints for:
 - steam pipes
 - seawater pipes
 - the fire main
 - bilge and ballast pipes
 - starting air pipes
 - control air pipes
- Explains how pipes are supported to reduce vibration
- Explains how expansion and contraction of pipes is catered for
- Names the materials used for the construction pipes carrying the fluids listed in the above objective
- Describes the principle construction of a cock and materials generally used
- Explains how the arrangement of ports in the plug is displayed
- Describes the main features of a globe valve
- Explains the difference between a screw-lift valve, a screw-down nonreturn valve and a nonreturn valve
- Describes the main features of a gate valve
- Describes a typical relief valve
- Lists and describes the applications of quick-closing valve
- Describes the main features of a quick-closing valve
- Makes a single line sketch of a change-over chest
- Explains the purpose and applications of change-over-chests
- Explains how pipelines are blanked off
- Describes the main features of a mud box

1.4.1.10 Deck Machinery (10 hours)

- 1) Windlass/mooring winch
 - Describes what components construct typical electric/hydraulic windlass/mooring winch systems
 - Explains the construction of windlass/mooring winch with visual aids/illustrations of typical ones

- Explains the operation mechanism of windlass/mooring winch with visual aids/illustrations of typical ones
 - Explains in simple words, speed control mechanism used in windlass/mooring winch with visual aids/illustrations of typical ones
- 2) Winch
- Describes components used in the construction of typical electric/hydraulic winch systems
 - Explains the construction of a winch with visual aids/illustrations of typical ones
 - Explains the operation mechanism of a winch with visual aids/illustrations of typical ones
 - Explains in simple words, speed control mechanism used in winch with visual aids/illustrations of typical ones
- 3) Boat winch
- Explains the construction of a boat winch with visual aids/illustrations of typical ones
 - Explains the operation mechanism of a boat winch with visual aids/illustrations of typical ones

1.4.2 SAFETY AND EMERGENCY PROCEDURES FOR OPERATION OF PROPULSION PLANT MACHINERY INCLUDING CONTROL SYSTEMS (30 hours) R1

Textbooks:T24,T26,T35,T50

Teaching aids: A1,A2,A3,V8,V9,V10,V11,V14

Required performance:

1.4.2.1 Main Engine Auto-slow down and Shut down (10 hours)

- Explains main engine auto-slow down and shut down taking a typical system as an example in terms of the following:
 - specific conditions
 - processes appeared until slow-slow down/shut down
 - transient phenomenon of the plant
 - procedures for recovery (changeover of manoeuvring position, manoeuvring method, eliminating causes and etc.)
 - main engine control system
- Explains main engine manual emergency slow down and shut down in terms of the following, taking a typical system as an example
 - specific conditions
 - impacts on the plant
 - procedures for recovery

1.4.2.2 Main Boiler Auto-shut down (10 hours)

- Explains main boiler auto-shut down taking a typical system as an example in terms of the following:
 - specific conditions
 - processes appeared until shut down
 - impacts on the plant under way and in port
 - procedures for recovery (eliminating causes, reigniting burner and etc.)
 - main boiler control system (changeover of control system, position and etc.)

1.4.2.3 Power Failure (Blackout) (5 hours)

- Explains briefly power supply system on board ships and its backup system
- Explains specific conditions of blackout and procedures for recovery responding to their causes taking a typical system as an example, including the following:
 - transient phenomenon of the plant

- equipment/installations to be promptly addressed
- sequential restarting auxiliaries
- auxiliaries to be manually restarted
- generator control system and power distributing system

1.4.2.4 Emergency Procedures for Other Equipment/Installations (5 hours)

1) Emergency steering (1 hour)

R1

- Describes how the system can be controlled from:
 - a local position in the steering compartment at the rudder head
 - an emergency steering position on deck
- Describes alternative systems of steering that can be used in an emergency

2) Others (4 hours)

- Explains precautions/procedures to be taken for the following:
 - operation of purifiers in case of blackout
 - heat exchangers under blackout
 - backup in case of control air failure
 - cooling seawater system in case of air ingress
 - clogged strainers/filters

1.4.3 PREPARATION, OPERATION, FAULT DETECTION AND NECESSARY MEASURES TO PREVENT DAMAGE FOR THE FOLLOWING MACHINERY ITEMS AND CONTROL SYSTEMS (70 hours)

R1

Textbooks:T24,T26,T35,T50

Teaching aids: A1,A2,A3,V8,V9,V10,V11,V14

Required performance:

1.4.3.1 Main Engine and Associated Auxiliaries (16 hours)

The following can be applied to diesel engine, steam turbine and gas turbine except for some of them:

- Explains the outline of main machinery system listing associated systems including their components
- States precautions, safety measures, checking procedures and points to be made as preparations before starting up main engine
- States the need for warming up/cooling down main engine or keeping it at hot condition unless cooling down has been done
- Explains the standard of completing warming up/cooling down main engine
- Explains precautions and typical procedures for warming up/cooling down main engine including theoretical rationale
- States precautions for starting associated auxiliaries to establish each system constructing propulsion machinery such as fuel oil, lubricating oil, cooling system and starting air system
- States particularly, precautions against auxiliaries which repair/overhaul was carried out
- States precautions to start main engine turning
- States the importance of carrying out all procedures in an orderly manner in order to prevent malfunction and damage
- States the need to carry out main engine trial run and necessary precautions
- States typical procedures for main engine trial run and checking points
- States procedures for changing over the propulsion machinery to the state of navigation
- Explains the critical speed/revolution caused by torsional vibration of shafting system
- Explains how the running conditions can be evaluated if it is in good working order in terms of running parameters, engine performance and operating range

- Explains how running parameters such as temperatures, pressures and levels can be determined in normal range
- Explains what malfunctions are likely occur due to running parameters getting out of the normal range
- Explains in simple words, how to calculate engine output
- Explains how the engine revolution is controlled
- Explains in simple words, the operating range including shaft revolution, ship's speed, engine output, engine torque and their relationships
- States the definition of torque rich
- Explains in simple words, the difference of output characteristic between diesel engine and steam turbine
- Explains the meanings of major running parameters to be strictly observed
- States the importance of engine-room rounds to detect sign of faults/malfunctions, emphasizing that running sound, leaking and vibration can be detected through engine-room rounds and these factors cannot be detected with monitoring system
- Describes how to carry out the cleaning of turbocharger under way
- Explains how to keep running of main diesel engine under the condition of cutting fuel oil to one cylinder or more
- Explains how to keep running of main diesel engine under the condition of reducing the number of turbochargers
- Describes the conditions which create dangerous oil mists in crankcases
- Describes the correct action to take when hazardous conditions are indicated in a crankcase
- Explains the importance of keeping scavenge air spaces and supercharge air-spaces drained and clean
- Describes the correct procedure and actions to take if a fire occurs in the scavenge air space or in the supercharge air space when an engine is running
- Describes the action to be taken if a turbocharger surges

1.4.3.2 Boiler and Associated Auxiliaries, and Steam Systems (16 hours)

- States procedures for igniting the burner manually and automatically
- States how to build up the steam pressure and to put boiler into service
- Explains precautions and necessary measures to be taken when getting up steam
- Explains the benchmark for building up steam pressure
- States the function of safety valve and how to adjust the setting point to blow
- Explains operation methods of boiler and economizer under way
- Explains precautions for using exhaust gas economizer
- Describes the method used to ensure that all pipes, cocks, valves and other fittings used for indicating water level are clear and in good working order
- Explains the treatment of boiler water including examination of properties of boiler water, including surface and bottom blow of boiler water
- States what is meant by soot blow including the function of soot blowers
- Explains what malfunctions /troubles likely happen to boiler on its operation
- States precautions for opening high temperature steam valves
- Explains how to keep boiler in cold condition while it is out of service
- Describes the correct procedures for operating steaming boilers in parallel on load
- Describes the correct procedures for checking the water level in steaming boilers
- Describes the danger of oil entering a boiler with the feedwater
- Explains what is meant by "blow-back"
- Explains how blow-back can be avoided
- Explains the need for, and the use of, soot blowers
- Explains why the temperature of boiler exhaust gases should be maintained above a minimum value

1.4.3.3 Auxiliary Prime Movers and Associated Systems (8 hours)

(Diesel engine)

- States precautions before starting an engine such as confirming fuel oil line, starting air line, cooling sea/fresh water line established and amount of lubricating oil inside the sump tank
- Describes briefly components constructing each associated system for an engine
- States preparations and procedures for manual start of an engine
- States the conditions of remote-auto start of an engine
- States the differences between manual start and remote-auto start of an engine
- Describes briefly the control system and its components including their function
- States the safety devices and their functions
- Lists the normal operating pressures and/or temperatures for:
 - exhaust gas
 - inlet air
 - circulating water at inlet and outlet
 - lubricating oil
 - fuel

(Steam turbine)

- States precautions before starting a steam turbine such as confirming steam line, gland steam line, lubricating oil line, condensate water line and circulating line
- Describes briefly components constructing each associated system for a steam turbine
- States preparations and procedures for start of a steam turbine
- Describes briefly the control system and its components including their function
- States the safety devices and their functions

1.4.3.4 Other Auxiliaries (30 hours)

1) Purifier and fuel oil treatment (8 hours)

R1

- States sequence of discharging sludge
- States why oil purifier needs following data concerning oil:
 - temperature
 - quantity of flow
 - density/specific gravity
- Explains the function of gravity disk
- Explains the function of low and high pressure water
- Describes sludge discharging mechanism of an oil purifier
- Explains the difference between purifying and clarifying
- Describes the purification process of fuel oil, starting the approximate temperatures of the oil necessary both in the supply tank and immediately prior to centrifuging
- Explains precautions for starting purifier and checking points to ensure a good working order
- Describes the correct procedures for the disposal of waste oil, sludge residue, etc.

2) Air compressor (4 hours)

R1

- States that cylinder lubrication must be kept to a minimum consistent with correct and safe operation
- States that cylinder lubricating oil should not have a flashpoint below 210°C and the use of synthetic lubricating oil to reduce a hazard
- Describes the attention required to keep the intake air filter working effectively
- Explains the reason for fitting drain valves after air coolers
- Describes the starting-up and stopping procedures
- Explains the principles upon which air compressors are run automatically
- Describes the particular quality required for compressed air that is to be used in control systems

- Explains how the required quality in the above objective is achieved
- 3) Evaporators and distillers (10 hours) R1**
- Describes the need for starting fresh water generator and the imitation of keeping its running
- Explains the outlines of starting procedures in accordance with typical type of fresh water generators
- (Control of water density and scale)**
- Explains how the formation of scale on the heating surfaces of coils, tubes and other heat-transfer elements is controlled
- States the limiting pressure and temperature in the shell in order to control the formation of scale
- Explains that the metallic salts in seawater constitute, on average, one part in every thirty two parts of liquid by mass; therefore, its density is sometimes quoted as being in 32nds
- States that the seawater in evaporator vessels is termed 'brine'
- Explains that the density of this brine is sometimes measured relative to that of seawater, e.g. $\frac{0.5}{32}$, $\frac{2}{32}$, $\frac{2.5}{32}$ etc.
- Explains why the density of the brine must be carefully controlled during the operation of an evaporator
- Explains how, when an evaporator is operating normally, the brine is maintained at optimum density
- States that excessive density of the brine should be avoided as it will cause the metallic salts contained in seawater to carry over with the vapour
- States the effect of maintaining the density of the brine too low
- Describes the type of scale deposited on the heating surfaces
- Explains how the scale described in the above objective is removed
- (Distillation) R1**
- Defines the term distillation as used in marine engineering practice
- Describes the function of a distiller as that of condensing fresh water from the vapour produced in an evaporator
- States that cooling is usually achieved by heat exchange with seawater flowing through tubes or coils
- (Drinking water) R1**
- Describes the quality necessary if the water being produced by a distiller is to be used for human consumption
- States that if, during the evaporation process, a temperature of 75°C is not achieved, chemical agents must be added to the water to destroy any harmful bacteria which may be present
- Explains how the water is made palatable
- States that seawater should not be evaporated when sailing in areas where pollution may be present, i.e. in rivers and estuaries, particularly in the vicinity of land drains or of discharges of sewage or industrial effluents
- 4) Refrigerator (8 hours)**
- States the preparation and precautions for starting a refrigerator
- States precautions and checking points on a refrigerator while its running
- States how the operating conditions is identified in a good working order
- States what malfunctions/troubles likely occur in refrigerators
- Describes the effect of variations in seawater temperature on the running of a refrigerating system
- Describes the effect in refrigeration unit of air, moisture and oil
- Explains how to charge refrigerant into a refrigerator and vice versa

- Explains how to charge lubricating oil into a refrigerator and vice versa
- Explains how to remove air from a refrigerator unit
- States how to inspect leaking of refrigerant
- States how to make a leak test for a refrigerator unit such as pressure test/ vacuum test

COMPETENCE 1.5	Operate fuel, lubrication, ballast and <i>other pumping systems and</i> associated control systems	<i>IMO Reference</i>
----------------	----------------------------------------------------------------------------------------------------------	----------------------

TRAINING OUTCOME

Demonstrates a knowledge and understanding of:

STCW Code
Table A-III/1

- 1.5.1 OPERATIONAL CHARACTERISTICS OF PUMPS AND PIPING SYSTEMS INCLUDING CONTROL SYSTEMS**
- 1.5.2 OPERATION OF PUMPING SYSTEMS**
- 1.5.3 OILY WATER SEPARATOR/SIMILAR EQUIPMENT REQUIREMENTS AND OPERATION**

COMPETENCE 1.5	Operate fuel, lubrication, ballast and other pumping systems and associated control systems	IMO Reference
----------------	---------------------------------------------------------------------------------------------	---------------

1.5.1 OPERATIONAL CHARACTERISTICS OF PUMPS AND PIPING SYSTEMS INCLUDING CONTROL SYSTEMS (10 hours) **R1**

Textbooks:T24, T50

Teaching aids: A1, A2, A3, V7, V11, V12

Required performance:

- States that performance will deteriorate if the temperature of the liquid being handled approaches that at which vapour is produced at the pressure in the suction pipe
- States that performance deteriorates if the viscosity of the fluid increases
- States that, if there is no positive head at the inlet to a centrifugal pump, a priming device must be used
- Describes or performs the correct procedure for starting up and stopping:
 - positive-displacement pumps
 - axial-flow pumps
 - centrifugal pumps
- making reference to:
 - suction valves
 - discharge valves
 - priming
- Explains the attention necessary of ensure the satisfactory operation of:
 - an adjustable gland
 - a non-adjustable gland
- Explains possible reasons for a loss of performance of a pump
- Lists the ship's services which receive a supply of:
 - seawater
 - fresh water

1.5.2 OPERATION OF PUMPING SYSTEMS (22 hours)

Textbooks:T24, T50

Teaching aids: A1, A2, A3, V7, V11, V12

Required performance:

1.5.2.1 Routine Pumping Operations (2 hours)

- States the need to understand the pipe lines constructing pumping systems to be daily used in order to maintain the normal operation of the plant
- States that the status of valves concerned in both manual and automatic pumping systems must be periodically checked
- States that any operation of pumping systems should be recorded in such a routine works record book

1.5.2.2 Operation of Bilge, Ballast and Cargo Pumping Systems (20 hours)

(Bilge)

R1

- Explains the purpose of a bilge pumping system
- Explains why nonreturn valves are fitted to bilge pipes in watertight compartments which contain the open end of the pipe
- Sketches a diagrammatic arrangement of a bilge pumping system, including the connections to other pumps

- Describes the purpose, siting and common principal connections of an emergency bilge suction
- Describes the principle features of an emergency bilge pump

(Ballast)

- Explains the purpose of a ballast pumping system
- Explains the fittings necessary when a space may be used for:
 - ballast or dry cargo
 - ballast or oil
- Sketches a diagrammatic arrangement of a ballast system

(Fresh water and Seawater)

- Lists the main uses of fresh water and seawater
- Describes a domestic fresh-water pumping system, explaining how:
 - the water pressure is maintained
 - the pump is started and stopped
 - the water is heated
- Describes a domestic seawater pumping system
- Describes the treatment necessary for water produced by evaporators for human consumption

(Hydraulic system)

- Lists the machinery which might be controlled or driven by hydraulic motors
- Describes a hydraulic system
- Describes the properties of hydraulic fluid
- Explains the care necessary when topping up the fluid from a hydraulic system

(Sewage system)

- Explains what is meant by a coliform count in sewage systems
- Explains what is meant by a sewage-retention system
- Explains the purpose of a sewage comminutor
- Describes the principles of a biological sewage treatment plant
- States that the effluent from a sewage plant must not be discharged in certain specified areas and that permission to discharge sewage must be obtained from the officer in charge of a navigational watch

(Incinerator)

- Explains briefly the purpose and operation of an incinerator for the disposal of:
 - sludge
 - refuse

(Fire main)

R1

- Explains, using a single line sketch, how a fire main is supplied with water, including the cross connections with other pumps
- States that the minimum number of independently driven fire pumps is laid down by international law
- States that, where installed, an independent fire pump, driven by a diesel engine, should be capable of being readily and repeatedly started
- Explains the purpose of the isolating valve in the machinery space fire-pump delivery main

(Fuel oil)

- States that fuel oil is stored in double-bottom tanks, wing tanks or special deep tanks
- Describes the venting arrangements for fuel tanks
- States that the two properties which indicate fluidity are viscosity and pour point
- Explains how fluidity of the fuel is achieved when fuel is to be transferred
- States the minimum closed flashpoint of marine fuels
- States the maximum temperature to which fuel oil may be raised for transfer and when stored in a settling tank
- States that:
 - oil leaks should be remedied as soon as possible

- oil dips should be collected in a container, which must be emptied very frequently
- cleanliness is essential
- Lists the precautions to be taken to avoid spillage when bunkering

1.5.3 OILY WATER SEPARATOR/SIMILAR EQUIPMENT REQUIREMENTS AND OPERATION (8 hours) R1

Textbooks: T24, T50

Teaching aids: A1, A2, A3, V7, V11, V12

Required performance:

- Describes the requirements necessary for oily water separators/similar equipment
- Describes the structure of oily water separators/similar equipment
- Describes the oil separation principles of oily water separators/similar equipment
- Describes the components constructing oily water separators/similar equipment
- States the reasons to use positive-displacement pump for oily water separators/similar equipment
- States the principles of oil content meter attached to oily water separators/similar equipment
- Explains how to prevent oil being mixed into discharging bilge when oil content exceeds 15 ppm
- States that fluid going through inside the pipe lines and oily-water separator/similar equipment can be correctly checked with pressure gauges
- States that pollution of the sea is an offence under international law
- States that the dumping of oil or oil-water mixtures is strictly prohibited
- States that there is a legal maximum oil content of water to be discharged overboard
- States that any discharge which could be contaminated must be passed through an oily-water separator which produces an effluent containing R1
less than 100 p.p.m. of oil under all inlet conditions
- States that the effluent should be further filtered to give an output containing a maximum of 15 p.p.m. of oil under all inlet conditions
- Describes, with the aid of a single line sketch, the operation of an automatic three-stage oily-water separator/similar equipment
- Lists the information which must be entered in the Oil Record Book when pumping out bilges

Officer in Charge of an Engineering Watch

Function 2:

**Electrical, Electronic and Control Engineering
at the Operational Level**

Officer in Charge of an Engineering Watch
Function 2: Electrical, Electronic and Control Engineering
at the Operational Level
INDEX

Part A2: Course Framework	67
Aims	
Objective	
Entry standards	
Course certificate	
Staff requirements	
Teaching facilities and equipment	
Teaching aids	
CDs&DVDs	
IMO references	
Textbooks	
Part B2: Course Outline and Guidance Notes	70
Timetable	
Lecture	
Course outline	
Guidance notes	
Part C2: Detailed Teaching Syllabus	76
Introduction	
Explanation of information contained in the syllabus tables	
2.1 Operate electrical, electronic and control systems	
2.2 Maintenance and repair of electrical and electronic equipment	

Function 2 - Electrical, Electronic and Control Engineering at the Operational Level

Part A2: Course Framework

Aims

This model course aims to meet the mandatory minimum requirements for knowledge, understanding and proficiency in Table A-III/1 of STCW 2010 for the function Electrical, Electronic and Control Engineering at the Operational Level.

Objective

This syllabus covers the requirements of the 2010 STCW Convention Chapter III, Section A-III/1. This functional element provides the detailed knowledge to support the training outcomes related to Electrical, Electronic and Control Engineering at the Operational Level.

This section provides the background knowledge and practical work to support:

- the safety requirements for working on electrical tasks;
- the ship's electrical engineering and electronics;
- control engineering; and
- power distribution systems.

Entry standards

This course is principally intended for candidates for certification as officers in charge of an engineering watch in a manned engine-room or designated duty engineers in a periodically unmanned engine-room. Those wishing to enter this course should be following an approved programme of on-board training.

Course certificate

On successful completion of the course and assessments, a document may be issued certifying that the holder has successfully completed a course of training which meets or exceeds the level of knowledge and competence specified in Table A-III/1 of STCW 2010, for the function Electrical, Electronic and Control Engineering at the Operational Level. A certificate may be issued only by centres approved by the Administration.

Staff requirements

Instructors shall be qualified in the task for which training is being conducted and have appropriate training in instructional techniques and training methods (STCW Code Section A-I/6). Depending on the complexity of the exercises set, an assistant instructor with similar experience is desirable for certain practical exercises.

Teaching facilities and equipment

A classroom equipped with an overhead projector and a blackboard, whiteboard or flipchart should be provided for teaching the theory of the course and holding group discussions.

The following equipment is recommended: model of an atom, apparatus to demonstrate static electricity, examples of electrical diagrams (i.e. block, system, circuit and wiring diagrams); ammeters, voltmeters, power meters, wiring, connectors, resistors, electrical sources¹(one set for every two trainees); a selection of marine cables, equipment and cable runs for testing purposes. insulation testers, continuity testers, digital and analogue multi-meters, thermostats, diodes, a clampmeter, live-line testers, lead-acid and alkaline batteries, a charging circuit, distilled water, hydrometer, magnets, iron fillings, solenoid, iron-cored solenoid, induction coil, model A.C. and D.C. generators, used A.C. and D.C. generators and motors, motor starters, switches, circuit breakers, fuses a sectioned transformer, an earth

lamp model system, various automatic control devices/equipment, automatic control unit available for simple experiment equipment suitable for use in oil, gas and chemical tankers.

- ¹ There are a number of units available containing circuits, meters and controls. which allow trainees to experiment easily with a variety of combinations of connections without risk of damage. Such equipment, although not essential, is of considerable value and is recommended.

Teaching aids (A)

- A1 Instructor Guidance (Part B of this course)
- A2 Manufacturers' manuals
- A3 Video cassette player

CDs and DVDs

- V1 Practical marine engineering knowledge series (Code No. 167.1–167.6)
- V2 Machinery alarms and protection devices (Code No. 528)

Available from: Videotel Marine International Ltd.
84 Newman Street, London W1P 3LD, UK
Tel : 44 171 299 1800
Fax: 44 171 299 1818
e-mail: mail@videotelmail.com
URL: www.videotel.co.uk

IMO references (R)

- R1 International Convention on Standards of Training, Certification and Watchkeeping for Seafarers (STCW), 1998 (IMO Sales No. 938), 1997 Amendments to STCW 95 (IMO Sales No. 945), and 2010 Amendments to STCW 95

Details of distributors of IMO publications that maintain a permanent stock of all IMO publications may be found on the IMO web site at <http://www.imo.org>

Textbooks (T)

- T12 Hall, D.T., Practical Marine Electrical Knowledge. London, Witherby & Co Ltd, 1984 (ISBN 0-900886-87-0)
- T28 Kraal, E.G.R., Basic Electrotechnology for Engineers. 3rd ed. London, Thomas Reed Publications Ltd, 1985 (ISBN 0-900335-96-3)
- T70 Code of Safe Working Practices for Merchant Seamen. London, The Stationery Office Publications Centre. 1998 (ISBN 0115518363)
- T72 LESLIE JACKSON,, REED'S INSTRUMENTATION AND CONTROL SYSTEM,, ADLARD COLES NAUTICAL, LONDON. 1992 (ISBN 0-7136-6731-1)

Function 2 - Electrical, Electronic and Control Engineering at the Operational Level

Part B2: Course Outline and Guidance Notes

Timetable

No formal example of a timetable is included in this model course.

Development of a detailed timetable depends on the level of skills of the trainees entering the course and the amount of revision work of basic principles that may be required.

Lecturers must develop their own timetable depending on:

- the level of skills of trainees;
- the numbers to be trained; and
- the number of instructors.

and normal practices at the training establishment.

Preparation and planning constitute an important factor which makes a major contribution to the effective presentation of any course of instruction.

Lectures

As far as possible, lectures should be presented within a familiar context and should make use of practical examples. They should be well illustrated with diagrams, photographs and charts where appropriate, and be related to matter learned during seagoing time.

An effective manner of presentation is to develop a technique of giving information and then reinforcing it. For example, first tell the trainees briefly what you are going to present to them; then cover the topic in detail; and, finally, summarize what you have told them. The use of an overhead projector and the distribution of copies of the transparencies as trainees handouts contribute to the learning process.

Course Outline

The tables that follow list the competencies and areas of knowledge, understanding and proficiency, together with the estimated total hours required for lectures and practical exercises. Teaching staff should note that timings are suggestions only and should be adapted to suit individual groups of trainees depending on their experience, ability, equipment and staff available for training.

Knowledge, understanding and proficiency	Total hours for each topic	Total hours for each subject area of Required performance
------------------------------------------	----------------------------	-----------------------------------------------------------

Competence

2.1 OPERATE ELECTRICAL, ELECTRONIC AND CONTROL SYSTEMS (280 h)

2.1.1 BASIC ELECTRICAL ENGINEERING (165 hours)

- .1 Electrical Theory (25 hours)
- .2 Fundamentals of Alternating Current (40 hours)
- .3 Generators (30 hours)
- .4 Power Distribution Systems (15 hours)
- .5 Electrical Motors (20 hours)
- .6 Electrical Motor Starting Methodologies (10 hours)
- .7 High-Voltage Installations (5 hours)
- .8 Lighting (5 hours)
- .9 Cables (5 hours)
- .10 Batteries (10 hours)

2.1.2 BASIC ELECTRONICS (45 hours)

- .1 Electron Theory (5 hours)
- .2 Basic Electronic Circuit Elements (20 hours)
- .3 Electronic Control Equipment (15 hours)
- .4 Flowchart for Automatic and Control System (5 hours)

2.1.3 BASIC CONTROL ENGINEERING (70 hours)

- .1 Fundamentals of Automatic Control (15 hours)
- .2 Various Automatic Control (5 hours)
- .3 ON-OFF Control (5 hours)
- .4 Sequential Control (5 hours)
- .5 Proportional-Integral-Derivative (PID) Control (10 hours)
- .6 Measurement of Process Value (20 hours)
- .7 Transmission of Signals (5 hours)
- .8 Manipulator Elements (5 hours)

Guidance Notes

The following notes are intended to highlight the main objectives or training outcomes of each part of the function. The notes also contain some material on topics which are not adequately covered in the quoted references.

Function 2: Electrical, Electronic and Control Engineering at the Operational Level

These notes have been included to provide additional information where appropriate.

2.1 OPERATE ELECTRICAL, ELECTRONIC AND CONTROL SYSTEMS 280 hours

2.1.1 BASIC ELECTRICAL ENGINEERING

Merchant ships may not carry specialized electrical engineers in their officer complement. In such cases it is common practice to delegate responsibilities for electrical engineering work to engineers qualified to keep watches. Even in cases where electrical engineers are on board, the watchkeeping engineer is still responsible for the safe and efficient operation of the electrical equipment during his duty periods. He is responsible for the generation and distribution of all electrical power and for the utilization of most of the load. He is also responsible for ensuring the availability of all of the protective and safety devices and for isolating machinery and equipment to allow inspection, maintenance and repair to take place. It is therefore important that trainees gain sufficient knowledge from theoretical studies, practical work and operational experience to become competent watchkeeping engineers.

The training in this topic provides the knowledge and skill to meet the requirements specified in Table A-III/1 of STCW 2010, which are knowledge and skills relating to generators, power distribution systems, electrical motors and electrical motor starting methodologies. It is noted that high-voltage installation has been added giving necessary precautions for handling; high-voltage was introduced into the competence table by the 2010 amendments to STCW.

It is intended that the subject should be practically based, that is, containing only enough theory to give an adequate understanding of the principles applying to operational practices. Wherever possible, actual equipment should be made available for trainees to work on. In cases where this cannot be works visits, ships' visits, colour slides, videos or illustrations may have to suffice; at least this will provide some level of familiarity.

All of the practical work should be performed by individual trainees, although it is recognized that in some cases small groups of two or three may be necessary.

Most modern, large ships have A.C. electrical supplies. Even so, some ships may have D.C. motors, fed by a rectified supply, for certain variable-speed applications. For these reasons, A.C. and D.C. practice must also be included.

Some revision will be necessary at the commencement of training outcome *alternating current* to re-establish the expression $e = Blv$ as a starting point. The expression $e = E_{max} \sin \theta$ is a most important contribution to the understanding of the principles of alternating current.

The inclusion of R.M.S. current for half cycle is to assist the understanding of r.m.s. value calculations.

Either a terminal box or a photograph of one will be necessary to complete training outcome *identifies outlets of three phases* and common neutral connection.

The variety and complexity of a.v. r.'s are such that trainees can be expected only to reach the level indicated by the training outcome.

Trainees may never come into contact with D.C. machines. Nevertheless, it is thought necessary to include at least the basic principles, which would prove to be essential knowledge if at some later date such machines were found to be installed. On some modern ships, where variable-speed drives are required, D.C. motors may be used with a rectified A.C. supply.

2.1.2 BASIC ELECTRONICS

This topic provides knowledge and skills relating to theory of electronic circuits and control equipment made by electronic technologies. It is noted that semiconductor and thyristor technologies should be understood by trainees in terms of basic theoretical knowledge as these subjects have become more essential than before due to a widespread use of high-voltage applications on board ships. The control equipment made by electronics is also highlighted due to the rapid advancement of computer and relevant technologies.

For the outcome referring to power, current, resistance, impedance, reactance power factor problems should be kept as simple as possible, for they are intended to enhance the training knowledge of operational practice and to emphasize the effect of inductance, inductive loads and their effect on the power factor. At this level, reactance is not obtained by using $X_L = 2\pi fL$; this comes in later studies. If reactance is needed to solve a problem, the value should be given.

2.1.3 BASIC CONTROL ENGINEERING

More specific subjects concerning control engineering should be strengthened in consideration of the diversity of control systems. Basic knowledge and understanding of PID control is most important since PID control is still utilized even in computer controls.

With regard to measurements of process value referred to so far, the knowledge and skills should be maintained in this section. This subject helps trainees understand the mechanism of sensing process values.

2.2 MAINTENANCE AND REPAIR OF ELECTRICAL AND ELECTRONIC EQUIPMENT

120 hours

2.2.1 SAFETY REQUIREMENTS FOR WORKING ON ELECTRICAL SYSTEMS

Useful safety precautions, rules and practices may be found in T12 and T70. It is essential that the trainee is keen to understand these precautions and follows them routinely when engaged in fault finding or repairs.

As such, trainees need to acquire an awareness for safety precautions for working on electrical tasks. Particularly, the special precautions for high-voltage installations must be acquired since the characteristics of high-voltage are quite different from the less than 1,000 V that has been usually used on board ships.

2.2.2 MAINTENANCE AND REPAIR

This topic includes knowledge and skills to carry out maintenance and repair on major electrical equipment in the machinery space and power distribution system (electrical wiring and D.C line). It must be effective for trainees to have opportunities to practice maintenance and repair as much as possible utilizing various practical materials concerning this subject.

2.2.3 DETECTION OF ELECTRIC MALFUNCTION AND MEASURES TO PREVENT DAMAGE

In this topic, fault protection and location have come (from the previous version of this model course.) also provides necessary knowledge and skills to carry out maintenance and repair and trainees should acquire them as well as from 2.2.2 MAINTENANCE AND REPAIR

2.2.4 CONSTRUCTION AND OPERATION OF ELECTRICAL TESTING AND MEASURING EQUIPMENT

This topic deals with electrical testing and measuring equipment usually used on board a ships, not including special testing and measuring equipment. Trainees need to acquire complete knowledge and skills for using this kind of equipment. Many opportunities to practice using them should be given to trainees.

2.2.5 FUNCTION AND PERFORMANCE TEST AND CONFIGURATION

This topic has been introduced due to a wide-spread use of remote/automatic control in the operation of ship's propulsion machinery and monitoring systems. Except for safety/protective devices, most equipment relating to monitoring and control systems in recent years are made by computer or relevant technologies and many functions have become available. Although the software for these systems cannot be updated or modified on board ships according to the IACS regulations, minimum knowledge and skills related to configurations and mechanism of monitoring and control systems need to be acquired.

2.2.6 ELECTRICAL AND SIMPLE ELECTRONIC DIAGRAMS

This topic provides trainees with interpretation of electrical and simple electronic diagrams and helps the trainees understand the functions and control mechanism of electrical/electronic equipment. In maintenance and repair, the ability to interpret electrical circuit diagrams and functions of electronic diagrams is required before commencing the work.

Part C2: Detailed Teaching Syllabus

Introduction

The detailed teaching syllabus is presented as a series of learning objectives. The objective, therefore, describes what the trainee must do to demonstrate that the specified knowledge or skill has been achieved.

Thus each training outcome is supported by a number of related performance elements in which the trainee is required to be proficient. The teaching syllabus shows the *Required performance* expected of the trainee in the tables that follow.

In order to assist the instructor, references are shown to indicate IMO references and publications, textbooks and teaching aids that instructors may wish to use in preparing and presenting their lessons.

The material listed in the course framework has been used to structure the detailed teaching syllabus; in particular,

- Teaching aids (indicated by A)
- IMO references (indicated by R) and
- Textbooks (indicated by T)

will provide valuable information to instructors.

Explanation of Information Contained in the Syllabus Tables

The information on each table is systematically organized in the following way. The line at the head of the table describes the FUNCTION with which the training is concerned. A function means a group of tasks, duties and responsibilities as specified in the STCW Code. It describes related activities which make up a professional discipline or traditional departmental responsibility on board.

In this Model course there are four functions:

- Marine engineering at the operational level;
- Electrical, electronic and control engineering at the operational level;
- Maintenance and repair at the operational level; and
- Controlling the operation of the ship and care for the persons on board at the operational level.

The header of the first column denotes the **COMPETENCE** specified in the Table A-III/1. Each function comprises a number of competences. For example, the Function 2, Electrical, Electronic and Control Engineering at the Operational Level, comprises two COMPETENCES. These competences are uniquely and consistently numbered in this model course.

The first competence in FUNCTION 2 is **Operate Electrical, Electronic and Control Systems** and it is numbered 2.1. The second competence is **Maintenance and Repair of Electrical and Electronic Equipment** and it is numbered 2.2. The term 'competence' should be understood as the application of knowledge, understanding, proficiency, skills, experience for an individual to perform a task, duty or responsibility on board in a safe, efficient and timely manner.

Shown next is the required TRAINING OUTCOME. The training outcomes are the areas of knowledge, understanding and proficiency in which the trainee must be able to demonstrate knowledge and understanding. Each COMPETENCE comprises a number of training outcomes. For example, the competence **Operate Electrical, Electronic and Control Systems** comprises a total of three training outcomes. The first is in BASIC ELECTRICAL ENGINEERING. Each training outcome is uniquely and consistently numbered in this model course. *Basic electrical Engineering* is numbered 2.1.1. For clarity, training outcomes are printed in black on grey, for example TRAINING OUTCOME.

Finally, each training outcome embodies a variable number of Required performances as evidence of competence. The instruction, training and learning should lead to the trainee meeting the specified Required performance. For the training outcome Characteristics and limitations of Materials used in construction and repair of ships and equipment, there are two areas of performance. These are:

2.1.1.2 Fundamentals of Alternating Current

Following each numbered area of Required performance there is a list of activities that the trainee should complete and which collectively specify the standard of competence that the trainee must meet. These are for the guidance of teachers and instructors in designing lessons, lectures, tests and exercises for use in the teaching process. For example, under the topic 2.1.1.2 Fundamentals of Alternating Current, to meet the Required performance, the trainee should be able to:

1) Alternating current

- Explains how alternating current is produced in a simple loop rotating in a magnetic field
- By means of sketches, relates the position of the loop in the above objective to the voltage wave form for one cycle at 90° intervals of rotation
- Explains the relationship between :
 - instantaneous voltage
 - conductor velocity
 - the sine of the displaced angle θ
- Sketches the wave form of an a.c. voltage

and so on.

IMO references (Rx) are listed in the column to the right hand side. Teaching aids (Ax), videos (Vx) and textbooks (Tx) relevant to the training outcome and required performances are placed immediately following the TRAINING OUTCOME title.

It is not intended that lessons are organized to follow the sequence of Required performances listed in the Tables. The Syllabus Tables are organized to match with the competence in the STCW Code Table A-III/1. Lessons and teaching should follow college practices. It is not necessary, for example, for Materials for construction and repair to be studied before Safe working practices. What is necessary is that all the material is covered and that teaching is effective to allow trainees to meet the standard of the Required performance.

COMPETENCE 2.1	Operate electrical, electronic and control Systems	IMO Reference
----------------	-------------------------------------------------------	---------------

TRAINING OUTCOMES

Demonstrates a knowledge and understanding of:

2.1.1 BASIC ELECTRICAL ENGINEERING

STCW Code
Table A-III/1

2.1.2 BASIC ELECTRONICS

2.1.3 BASIC CONTROL ENGINEERING

COMPETENCE 2.1	Operate electrical, electronic and control Systems	IMO Reference
----------------	----------------------------------------------------	---------------

2.1.1 BASIC ELECTRICAL ENGINEERING (165 hours) R1

Textbooks: T12, T28

Teaching aids: A 1, A2, A3, V1

Required performance:

2.1.1.1 Electrical Theory (25 h)

1) Ohm's law

- Describes the effect of resistors in a circuit and uses the symbol R
- Names and uses the symbol Ω
- Defines the unit of resistance
- Defines Ohm's law
- Defines Ohm's law to find current, voltage and resistance in simple problems
- Describes how the current through and the voltage across resistors are affected in series and in parallel circuits

2) Kirchhoff's law

- States and applies Kirchhoff's:
 - voltage law
 - current law
- Calculates the current flowing and the voltage drop across resistors in simple circuits
- Constructs and uses a Wheatstone Bridge
- Given the voltage and total current, calculates the total (or equivalent) resistance of a parallel circuit
- Given the values of the resistances in a parallel circuit, calculates the total resistance
- Compares the effect of adding a further resistance to:
 - a parallel circuit
 - a series circuit
- Explains how the objective affects the e.m.f. and the terminal potential difference of a supply, demonstrating the effect by calculations and by experiment
- Explains the effect of internal resistance in the supply source
- Determines current flows, resistance values and voltages in:
 - series circuits
 - parallel circuits by calculation

3) Electrical circuit

- States that current can only flow in a closed circuit
- Explains why some materials are
 - conductors
 - insulatorsand names commonly used materials in each group
- Names the different sources of electricity and explains their effect when connected to a conductor
- Explains potential difference and electromotive force, stating the units and the symbols used
- Explains the current flow, stating its symbol(I)
- States that current strength is measured in amperes, represented by A
- States that a steady current flowing in a single direction is called a direct current (D.C.)
- States that when the direction of flow of a current is continually reversing it is called an alternating current (A.C.)

- States that in modern ships the main supply is usually A.C. but that D.C. has many uses
 - Describes what is meant by static electricity
 - Describes electrostatic charging and the principles of overcoming potential hazards
- 4) Impedance and Inductance**
- Explains what is meant by "impedance" and uses the correct symbol
 - Compares impedance of an A.C. circuit with resistance of a D.C. circuit
 - States the relationship between impedance, voltage and current
 - Compares the effect in an A.C. circuit and in a D.C. circuit of:
 - a simple resistance
 - the same resistance wound in the form of a coil
 - the same coiled resistance, into which an iron core is inserted
 - Describes what is meant by "reactance" and uses the correct symbol
 - Sketches the impedance triangle, indicating R , X , Z and the phase angle (ϕ)
 - States that the cosine of the phase angle is called the power factor
 - Calculates impedances and power factors, given the resistance and reactance of coils
 - Explains the effect of changing current and its associated magnetic flux on the induced e.m.f.
 - Explains why, in a circuit containing only reactance, there is a difference in phase of 90° between the applied voltage and the current
 - Sketches graphs showing the variation of current, applied voltage and back e.m.f. over one cycle when an A.C. is applied to:
 - a circuit containing only pure resistance
 - a choke having inductance only
 - Superimposes a curve representing the power dissipated in both cases in the above objective
 - States the value of the power factor in both cases in the above objective
 - States that, in practice, an inductor will always have a resistance
 - Sketches a phasor diagram for a circuit containing an inductance which has resistance, indicating the resultant applied voltage and the phase angle
 - States that in cases such as those in the above objective, i.e. in inductive circuits, the current always lags the applied voltage
 - States that shipboard installations produce power demand with a lagging power factor
 - Explains the effect of varying power factor on the power consumed
 - States that $\text{power} = V \times I \times \frac{R}{Z}$ or $V \times I \times \cos\phi$
 - Solves simple problems concerning power, current, resistance, impedance, reactance and power factor and verifies the solutions, using laboratory equipment

2.1.1.2 Fundamentals of Alternating Current (40 hours)

1) Alternating current

- Explains how alternating current is produced in a simple loop rotating in a magnetic field
- By means of sketches, relates the position of the loop in the above objective to the voltage wave form for one cycle at 90° intervals of rotation
- Explains the relationship between :
 - instantaneous voltage
 - conductor velocity
 - the sine of the displaced angle θ
- Sketches the wave form of an a. c. voltage
- Shows diagrammatically a simple circuit for a three-phase supply from an alternator
- Develops the expression $\epsilon = B l v$ to produce $\epsilon = E_{max} \sin\theta$, where ϵ is the instantaneous voltage, E_{max} is the maximum voltage and θ is the displaced angle
- Projects the vertical components of a rotating vector to draw one complete cycle of a sine wave

- States that the rotating vector is called a phasor
- Using a triangle produced from the above objective, confirms that $\frac{e}{E_{max}} = \sin\theta$
- Superimposes degrees and radians on the sine wave drawn in the above objective
- Uses the correct symbols and conventions for:
 - Rotation
 - angular velocity
 - periodic time
 - frequency
 - peak value
 - amplitude
- Deduces the expression $e = E_{max} \sin\theta$
- Calculates instantaneous voltages, given the unknown quantities
- Explains what is meant by phase difference between voltage and current values
- Explains why root mean square (r.m.s.) values are used
- Given a series of values of instantaneous voltage or current for a half cycle, calculates r.m.s. value
- States that the r.m.s. value for a sine wave is 0.707 of the peak value

2) Electromagnetic induction

- Describes the principle of electromagnetic induction and states its main applications
- Explains how the following factors affect the induced voltage:
 - flux density
 - number of turns in the coil
 - conductor/flux cutting rate
- Explains Faraday's law of electromagnetic induction
- Explains Lenz's law
- Explains in simple terms the principle of static induction, to include mutual induction and self-induction

3) Work, energy and power

- Explains the difference between work, energy and power, giving the units and symbols commonly used
- States that $work = current \times time \times voltage$, giving the units used
- Makes simple calculations to determine energy and work
- Defines power, giving the units and symbols used
- From the above objective, derives the expression $power = voltage \times current (P = VI)$, giving the units used
- Using the equations from above objectives, derives $P = I^2 R$ and $P = \frac{V^2}{R}$

2.1.1.3 Generators (30 hours)

1) A.C. Generators

- Uses Fleming's hand rules to determine the directions of magnetic field, motion and current
- On an actual machine, or by using a given diagram that shows the arrangement of a simple generator, identifies and explains the function of:
 - the armature
 - slip rings
 - brushes and springs
 - field poles
 - field coils
- Sketches a graph showing the variation of e.m.f. when a simple loop generator coil is rotated between two poles
- States the range of voltage and frequency at which ships' electrical power is generated

- States that the A.C. voltages normally given are root mean square values and that all equipment is rated in these terms
- States that peak values are 2 times larger than r.m.s. values
- Describes in simple terms an A.C. generator with three-phase windings, stating the phase difference
- Sketches a schematic arrangement of a three-phase alternator with star connection
- In the terminal box of a stator field winding, identifies the outlets of the three phases and the common neutral connection
- Explains how excitation of the rotor is produced and supplied
- Describes how a generator is cooled
- Lists the parts of a generator fitted with temperature alarms
- Explains why heaters are fitted to a generator
- Explains the function of an automatic voltage regulator
- Sketches a block diagram of an automatic voltage regulator, naming the main components and explaining the purpose of the hand trimmer
- Explains such sources of supply can be run in parallel and those which cannot
- Performs or describes the synchronizing sequence to bring a generator into service in parallel with a running generator, using both a synchroscope and lamps
- Adjusts, or describes how to adjust, the load sharing of two generators running in parallel
- Either performs the procedure, or describes how, to reduce the load on a generator and takes it out of service
- States that load sharing can be automatically controlled
- States that the emergency generator feeds its own switchboard and that both are usually installed in the same compartment above the waterline
- Describes the connections between the emergency and main switchboards and the necessary safeguards
- Describes the situation where the emergency generator would be started up automatically and the methods of starting
- Describes the regular "no load" running and the occasional "on load" running of the emergency generator

2) D.C Generators

- Sketches, in diagrammatic form, the basic circuit for a D.C. generator
- On a given drawing or an actual generator, identifies the field poles, yoke, shoe, field windings and interpoles
- Describes the differences in appearance of shunt coils and series coils
- On a given drawing or an actual generator, identifies the windings, commutator, commutator insulation, laminations, clamping arrangement, ventilation holes, coil-retaining arrangements, brushes, tails, brush loading arrangement and bearings
- Names the two types of winding used on armatures
- On an actual machine or by using a given diagram that shows the arrangement of a simple direct-current generator, identifies and explains the function of:
 - the armature
 - the commutator
 - brushes and springs
 - field poles
 - field coils

2.1.1.4 Power Distribution Systems (15 hours)

1) Distribution

- Explains the basic purposes of switches, circuit breakers and fuses
- Describes briefly the principle of the various types of closing mechanism of circuit breakers
- Lists the ways in which a circuit breaker can be tripped

- Explains the purpose of interlocks fitted to circuit breakers
- Lists the essential services which are supplied by electrical power
- Explains the purpose of an emergency power supply
- States the possible sources of emergency power supply and how they are brought into use
- Draws a system diagram of a typical distribution system, showing:
 - main generators
 - emergency generators
 - shore supply
 - battery charging
 - 440 volt supply
 - 220 volt supply
 - circuit breakers
 - transformers
- By means of simple sketches, shows the difference between insulated systems and earthed-neutral systems

2) Insulation

- Explains what is meant by an insulator and the purpose of insulation
- Describes leakage in an insulated cable
- Explains why the insulation resistance of large installations is normally relatively lower than those of small installations
- Describes the factors which affect the value of insulation resistance
- Explains why the current-carrying capacity of a machine is governed by its insulation
- Describes what is meant by insulation resistance and explains how it often deteriorates
- Describes the materials and general physical characteristics of insulation materials and the factors and conditions which cause deterioration
- States the maximum temperature which common insulation materials can withstand and the maximum ambient air temperature used in design
- Explains why the ventilation and cooling of insulation is essential

3) Transformers

- States that transformers on ships are usually air-cooled
- Shows diagrammatically the connections between the main switchboard and the main distribution board through:
 - delta-delta transformers
 - delta-star transformers
 - delta-star transformers with an earthed neutral
- Describes the procedure when connecting up to a shore supply

2.1.1.5 Electrical Motors (20 hours)

1) A.C. motors

- States the normal supply for three-phase induction motors
- Names the types of motor commonly used on board ships, giving their applications
- Given the actual components from a three-phase induction motor, identifies:
 - rotor
 - bearings
 - fan
 - stator
 - field windings
 - rotor cage
 - method of lubrication
 - terminals
- Explains the differences between the following motor enclosure, describing how cooling is achieved in each case:

- drip-proof
- totally enclosed
- deck watertight
- flameproof
- Sketches a graph showing the relationship between speed and load and between current and load, from no load to full load
- Given a motor name plate, explains the meaning of all of the information displayed
- Explains in simple terms how the driving torque is produced in an induction motor
- Explains why slip is essential

2) D.C. motor

- Explains what is meant by the back e.m.f. (E_b) of a motor
- Relates the supply voltage to the back e.m.f. and to the voltage drop in the armature ($V = E_b + I_a R_a$)
- Explains why the starting current is high compared to the load current
- Explains why a starter is required and the principle involved
- States that rotational speed (N) is approximately proportional to:
$$\frac{\text{applied voltage}}{\text{field flux}} \text{ or } N \propto \frac{V}{\Phi}$$
- From the above objective, explains how the rotational speed is affected by:
 - varying the voltage
 - varying the strength of the magnetic field
- Describes typical applications of:
 - shunt motors
 - series motors
- In compound motors, explains what is meant by:
 - long shunt
 - short shunt
 - cumulatively connected

2.1.1.6 Electrical Motor Starting Methodologies (10 hours)

- Explains the following starting methods for D.C. motors and its characteristics:
 - starting rheostat
 - automatic starter
- Explains the following starting methods for A.C. motors and its characteristics:
 - direct on line starting
 - star-delta starting
 - compensator starting
- States what should be taken into consideration when selecting starting methods for A.C. motors
- Explains the basic reason for the provision of motor protection
- Explains the principles of the most common over current relays
- Explains the difference between the largest possible overload current and a fault current
- Describes the function of the overcurrent trip, time delays and fuses with both overload and fault currents
- Explains the basis upon which fuses are chosen
- Explains the principle of a thermal relay, including the means of its adjustment
- Explains what is meant by single phasing and its effect on a motor:
 - when running
 - when starting
 - if continued attempts to start are made
- Describes in principle the protection against running with a phase open circuited
- Explains why under voltage trips are necessary
- States applications where the following speeds are suitable:

- single fixed speed
- two or three fixed speeds
- infinitely variable speed
- Describes briefly how stepped speeds can be provided
- Lists the means of producing variable speed
- Describes the principle of the Ward-Leonard drive
- Explains the principle of a variable-frequency motor

2.1.1.7 High-Voltage Installations (5 hours)

- States that more than 1,000 V is usually called high-voltage
- States how and why high-voltage installations are used on board ships
- States what voltages are mostly used as high voltage on board ships
- Describes equipment/installations in high-voltage systems such as high-voltage generator, distribution board, motors etc.
- States the special characteristics and features of high-voltage installations in comparison with less than 1,000 V
- States that high-voltage systems are normally earthed via a resistor
- Explains how the presence of earth faults is indicated in a high-voltage system with an earthed neutral
- States safety precautions to be strictly observed to prevent accidents when working on high-voltage electrical equipment
- States that any operation of high-voltage installations must be carried out remotely at places where a certain distance is being kept from the installations

2.1.1.8 Lighting (5 hours)

- States that correct levels of lighting are vital to safety, efficiency and comfort
- Describes the principle of the incandescent lamp
- Explains the difference between lamps for general lighting and for rough service
- Describes briefly the principle, application and care when handling tungsten-halogen lamps
- Explains the principle of discharge lamps
- Explains how fluorescent tubes are started up
- Explains how the power factor of fluorescent tubes is improved
- Explains how radio interference is suppressed in a fluorescent tube
- Explains the effect of variation in voltage on both incandescent and gas-discharge lamps
- Explains how energy lights are marked
- States which emergency lights are on the emergency switchboard system and which lights may be on the battery circuit
- Explains why the correct power of lamp should be used

2.1.1.9 Cables (5 hours)

- Names materials commonly used for the following part of cables:
 - conductors
 - insulation
 - sheathing
- Describes the reaction of electric cables to a fire
- Explains why cable sockets need to be securely attached and locked on to the terminal

2.1.1.10 Batteries (10 hours)

- Describes the principle of the voltaic cell
- Quotes an example of and explains the difference between:
 - primary cells
 - secondary cells
- Lists the routine and emergency services normally supplied by batteries

- States the range of voltages and/or alkaline batteries are used
- States that lead-acid and/or alkaline batteries are used
- Explains the effect on current and voltage when connecting cells:
 - in series
 - in parallel
- States that 12 lead-acid or 20 alkaline cells connected in series produce a nominal 24 volts
- Explains how cells or batteries are connected to increase their capacity
- Explains how capacity is stated and what it means
- Describes the dangers which may exist in a battery compartment and explains how they are overcome
- Explains the topping up procedure for batteries
- Describes how batteries are recharged and the periods during which gassing takes place
- Describes how a battery is connected for recharging
- Explains how the condition of an alkaline battery is determined
- Explains the effect of the internal resistance of a battery on its terminal voltage
- Demonstrates the above objective by means of simple examples
- Describes the first-aid necessary if parts of the body and eyes are in contact with electrolyte from:
 - a lead-acid battery
 - an alkaline battery
- States that the appropriate first-aid equipment should be available in the place where the batteries are housed

2.1.2 BASIC ELECTRONICS (45 hours)

R1

Textbooks: T12, T28, T72

Teaching aids: A 1, A3, V5

Required performance:

2.1.2.1 Electron Theory (5 hours)

- Explains what is meant by:
 - an atom
 - an element
 - a compound
 - a molecule
- Explains the composition of an atom in terms of electrons, protons and neutrons and the balance of electrons and protons
- States that electrons orbit the nucleus, their increasing energy level being proportional to their distance from it
- Describes the effect of applying energy to an atom
- Describes the flow of current in a conductor subjected to a potential difference, referring to:
 - electron flow
 - conventional flow
- Explains the significance of the number of electrons in the outer shell, with reference to:
 - inert elements
 - positive ions
 - negative ions
 - ionization

2.1.2.2 Basic Electronic Circuit Elements (20 hours)

1) Semiconductor

- Defines the semiconductor

- Describes how semiconductors are utilized
- Explains the current and the free electrons in the semiconductor
- Explains what types of intrinsic/extrinsic semiconductor are
- Explains the following characteristics of semiconductors
 - photoelectric effect
 - thermoelectric effect
 - communicating action
 - hall effect
- Explains the following with regard to semiconductors:
 - P-N junction and its properties
 - semiconductor diode rectification
 - structure of diode
 - function principle
 - transistor amplification effect

2) Thyristor

- Defines the thyristors
- Lists various types of thyristors and describes their actions and characteristics
- Describes how thyristors are utilized, taking some applications as examples
- States advantages and disadvantages when using thyristors

3) IC and LSI

- Defines Integrated Circuit (IC) and Large Scale Integrated Circuit (LSI) as circuit elements
- Describes the structures of IC
- Describes briefly the functions of the following types of IC
 - Transistor Transistor Logic (TTL)
 - Emitter-Coupled Logic (ECL)
 - Complementary Metal-Oxide Semiconductor (CMOS)
 - Erasable Programmable Read-Only Memory (EP-ROM)
 - Random Access Memory (RAM)
 - Central Processing Unit (CPU)

2.1.2.3 Electronic Control Equipment (15 hours)

- Defines the following electronic control equipment and states briefly their control mechanism
 - relay circuit unit
 - digital sequential control devices
 - Integrated Automation Control and Monitoring System (IACMS)
 - Programmable Logic Controller (PLC)
 - analogue/digital/computer PID Controller
 - computer programmable controller
- States how control equipment cited above are utilized for main engine control, CPP, generator control, boiler control and auxiliaries control in terms of the following:
 - main engine; start/stop, revolution, various injection timing control, electronic governor and the others (auto-load, crash astern, automatic shut down, slow down, etc)
 - controllable Pitch Propeller (CPP); autoloading/blade angle control
 - generator; generator automatic control (GAC) (auto-synchro, load sharing, etc) primary mover start/stop sequence
 - boiler; Automatic Combustion Control (ACC), burner control, Feed Water Control (FWC), Steam Temperature Control (STC),
 - auxiliary machinery; purifier automatic control (automatic sludge discharge), temperature/level/pressure/viscosity control

2.1.2.4 Flowchart for Automatic and Control Systems (5 hours)

- Explains symbol marks used in flow charts such as terminal, processing, determination, input/output, etc
- States what is understood with flow charts
- Explains flow charts indicating automatic control system for main engine, generator control system and others taking some of them as examples
- Describes briefly the major components in relation to the function found in the flow charts

2.1.3 BASIC CONTROL ENGINEERING (70 hours)

R1

Textbooks: T12, T28, T72

Teaching aids: A 1, A2, A3, V1

Required performance:

2.1.3.1 Fundamentals of Automatic Control (15 hours)

- Defines an automatic control and states its purpose
- Describes what devices/equipment construct control systems and their role/functions
- Relates sensing unit, controller, controlled variable, manipulating variable and controlled object to each of them in the control system
- Describes what sort of devices are included in the sensing unit
- Describes variety of controllers such as electronic (PID, PLC, computer) controller and pneumatic controller
- Defines setting value, input value, deviation and output value/controlled variable in the controller
- Describes what sort of devices are included as manipulators
- Describes variety of controlled object
- Describes how automatic controls are utilized in the ship's propulsion machinery, taking examples of temperature and level control systems, including control parameters such as time lag, time constant, dead time, first/second-order lag element, disturbance and offset

2.1.3.2 Various Automatic Controls (5 hours)

- Classifies systematically automatic controls in terms of control methodologies
- States what an optimal control means
- Explains briefly feedback control and feedforward control
- Describes briefly ON-OFF control, sequential control, PID control and program control
- Explains how these automatic controls are applied to the control systems
- Explains briefly program control and how the control is realized
- Describes the applications of program control in the ship's propulsion machinery

2.1.3.3 ON-OFF Control (5 hours)

- Explains what ON-OFF control means
- Explains the characteristics of ON-OFF control
- Explains how ON-OFF control is utilized
- Lists components comprising ON-OFF control system
- Describes ON-OFF control taking some applications as examples

2.1.3.4 Sequential Control (5 hours)

- Explains what a sequential control means
- Explains the characteristics of a sequential control
- Explains how a sequential control is utilized
- Lists components comprising a sequential control system
- Describes sequential controls taking some applications as examples

2.1.3.5 Proportional-Integral-Derivative (PID) Control (10 hours)

- Explains the principles/theory of PID control
- Explains how P, I and D actions can be electrically/pneumatically available showing simple electronic circuits and pneumatic diagrams
- States that PID control is classical control methodology but even now, it is still firm basis for controlling any physical/process value
- States that PLC and computer controller produces the same actions as analog PID controller when controlling physical/process value
- Explains P, I, D, PI, PD and PID actions respectively using step or ramp input
- Explains the characteristics of P action as well as proportional band (PB)
- Explains the characteristics of I and D actions
- Explains how P, I and D actions contribute to control systems, stating that P value contributes to strength of control, I value contributes to accuracy of control and D value contributes to speed of control
- Describes the step response test to PID action and what can be understood by its results
- Explains how P, I, and D parameters for optimal control can be determined
- Describes the components comprising PID control systems including sensing unit, transducer, manipulator and controller

2.1.3.6 Measurement of Process Value (20 hours)

1) Temperature (Mechanical)

- States that it is common practice to call the measuring instrument for temperatures
 - above 500°C a pyrometer
 - below 500°C a thermometer
 - States the temperature range for which mercury is used
 - Names the fluids which can be used for the measurement of lower temperatures
 - Describes the principal features of thermometers based on the filled system, including:
 - mercury in steel
 - vapour-pressure
 - gas -filled
 - Describes the principal features of a bimetallic thermometer
- #### **(Electrical)**
- States that the range and accuracy varies according to the material used in the detecting element
 - Sketches and describes a resistance-type measuring instrument based on the Wheatstone bridge
 - Describes the characteristics of a thermistor and the conditions for which it is suitable
 - Sketches a circuit used in a thermocouple and describes its operation
 - Describes the principles of an optical pyrometer

2) Pressure

- Describes the principle features of, and compares, the following:
 - manometers
 - simple water
 - wide-cistern or well
 - inclined-tube
 - mercury
 - pressure gauges
 - Bourdon
 - diaphragm-sealed gauge
 - Schaffer
 - twin-bellows differential-pressure cell
 - strain gauge

- Describes how pressure gauges can be tested on board ship
- Tests a pressure pump
- Sketches calibration curves for a Bourdon pressure gauge, showing the effect of:
 - zero adjustment
 - multiplication adjustment
 - angularity adjustment
- States that calibration and testing are normally performed by specialists

3) Level

(Direct Methods)

- Describes the principle of a float-operated level-measuring device
- Describes the principle of a probe element
- Describes a displacement gauge

(Inferential Methods)

- Explains the principle of inferential methods
- Describes a level sensor based on immersed resistors
- Describes a level indicator based on a bubbler system
- Describes a pneumatic gauge

4) Flow

- Explains the difference between a quantity metre and a rate-of-flow-flow metre
- Explains that a quantity metre is basically a rate-of-flow metre combined with an integrator
- Describes the function of the two elements of a flow metre
- Sketches a graph to show the relationship between velocity of a fluid and its pressure difference
- From the above objective, shows the velocity is proportional to the square root of pressure
- Explains the situations in which extractions of square roots are necessary
- Describes the principal features of:
 - a rotometer
 - an electrical flowmeter
 - a rotameter
- Sketches an orifice and a Venturi, showing the direction of flow and the pressure-measuring points
- Explains how a manometer can be used as a square-root extractor when measuring the pressure difference in an orifice or Venturi
- States that extraction of a square root can also be accomplished pneumatically and electrically

5) General Measurement of Processes

- Explains the principles of a tachometer
- Explains the principles of A.C. and D.C. electric tachometers
- Explains the principles of a torque metre based on the effect of stress in a magnetic field
- Explains how the above objective can be developed to measure power
- Explains the principal features of a viscometer
- Describes the application of a photoelectric cell to:
 - an oil-in-water
 - a smoke-density detector
 - an oil-mist detector
 - a flame detector
- Describes the common types of fire detector
- Describes the principal features of:
 - an explosive-gas detector

- a vibration monitor
- an oxygen analyser
- a CO₂ analyser
- a relative humidity metre
- salinity measurement
- a dissolved-oxygen metre
- a pH metre
- Describes or performs routine setting up, testing and maintenance of the measuring devices included in the above objectives

2.1.3.7 Transmission of Signals (5 hours)

1) Transmitters

- Describes the function of a transducer

2) Controlling Elements (Pneumatic)

- Describes the flapper and nozzle arrangement
- Explains what is meant by negative feedback and by positive feedback
- Sketches a flapper and nozzle arrangement with negative feedback
- Explains the function of a force-balance transducer
- Describes the principle features of an electro pneumatic transducer

(Electrical)

- Uses a Wheatstone bridge used as a transducer
- Describes the principles of a variable-inductance
- Describes the principles of a variable-capacitance transducer
- Describes the principles of an electronic force-balance system
- Describes the principles of a voltage-current transducer

(Receivers)

- Describes the principal features of:
 - a pneumatic receiver integrator
 - a potentiometric pen recorder
- Explains the function of an X-Y recorder
- Describes the basic principles of ac and dc position motors

2.1.3.8 Manipulator Elements (5 hours)

1) Pneumatic

- States that the final controller might be operated pneumatically, hydraulically or electrically
- Sketches a diaphragm-operated control valve
- Describes the characteristics of the motor element and the correcting element in the above objective
- Describes or, preferably, determines by experiment the flow characteristics and applications of:
 - mitre valves
 - vee-ported valves
- Explains what is meant by "turn-down ratio"
- Describes the conditions which may dictate the need for a positioner
- Describes the principal features of a positioner
- Explains the circumstances when piston actuators might be used
- Describes the conditions where butterfly valves might be used
- Describes the wax-element temperature-control valve and states its normal temperature range

2) Electrical Servomotors

- Describes a dc servomotor and explains how it varies from the common motor
- Explains the problems of using a three-phase ac machine as a servomotor
- Describes the applications of a two-phase ac servomotor, explaining how its characteristics can be varied

3) Hydraulic Servomotor

- Describes the principles of a swash plate pump
- Explains the advantage of using high pressures
- Explains the applications of a hydraulic ram servomotor

COMPETENCE 2.2	Maintenance and repair of electrical and electronic equipment	IMO Reference
----------------	---------------------------------------------------------------	---------------

TRAINING OUTCOMES

Demonstrates a knowledge and understanding of:

- | | | |
|--------------|---------------------------------------------------------------------------------|----------------------------|
| 2.2.1 | SAFETY REQUIREMENTS FOR WORKING ON ELECTRICAL SYSTEMS | STCW Code
Table A-III/1 |
| 2.2.2 | MAINTENANCE AND REPAIR | |
| 2.2.3 | DETECTION OF ELECTRIC MALFUNCTION AND MEASURES TO PREVENT DAMAGE | |
| 2.2.4 | CONSTRUCTION AND OPERATION OF ELECTRICAL TESTING AND MEASURING EQUIPMENT | |
| 2.2.5 | FUNCTION AND PERFORMANCE TEST AND CONFIGURATION | |
| 2.2.6 | ELECTRICAL AND SIMPLE ELECTRONIC DIAGRAMS | |

COMPETENCE 2.2	Maintenance and repair of electrical and electronic equipment	IMO Reference
----------------	---------------------------------------------------------------	---------------

2.2.1 SAFETY REQUIREMENTS FOR WORKING ON ELECTRICAL SYSTEMS (10 hours) **R1**

Textbooks: T12, T28, T70
Teaching aids: A 1, A3, V4

Required performance:

- Describes the cause of electric shock, giving the level of current which could be fatal
- States the voltage range which is considered safe
- Applies safety precautions necessary when working on electrical equipment in practice
- States the isolation procedures required for electrical equipment
- States the safety and isolation precautions necessary before commencing work
- Explains the purpose of interlocks fitted to circuit breakers
- Explains the danger associated with the spaces in the vicinity of busbars
- Explains the potential danger of instrument voltage/current transformer circuits and the safe procedure for working on such circuits
- Describes the protection normally provided on the doors of switchboard cubicles
- Explains that safety and emergency procedures are documented in the ship's safety management system

R2 Ch. IX

2.2.2 MAINTENANCE AND REPAIR (50 hours) **R1**

Textbooks: T12, T28,
Teaching aids: A 1, A2, A3, V1

Required performance:

2.2.2.1 Principles of Maintenance (5 hours)

- Explains the need for maintenance
- Describes briefly what is meant by:
 - breakdown maintenance
 - planned maintenance
 - condition monitoring

2.2.2.2 Generator (5 hours)

- States the safety and isolation precautions necessary before commencing work
- Lists the parts to be inspected, their common faults and the necessary remedial action
- Tests and records values of insulation resistance
- Performs routine maintenance and testing of a generator

2.2.2.3 Switchboard (5 hours)

- Describes or carries out a maintenance routine on main circuit breakers
- Describes the care to be taken when handling circuit breakers
- Detects and corrects faults implanted in circuit breakers

2.2.2.4 Electrical Motors (5 hours)

- Lists the principle maintenance equipment for motors
- Carries out the maintenance necessary for a cage electric motor, paying particular attention of:
 - damp, condensation and air flow
 - dust and oil
 - external and internal surfaces
 - frequency of maintenance
 - deterioration of insulation
 - cleaning, inspection, renewal and lubrication of bearings
- describes the most common causes of failure of insulation
- checks the insulation resistance of a three-phase induction motor

2.2.2.5 Starters (5 hours)

- Carries out the maintenance necessary, and completes reports on, starters and controllers, with specific reference of:
 - casings, corrosion and bonding
 - contactors, magnet faces, pitting, overheating, spring force, lubrication
 - connections, cables and leads
 - correct operation when in use
- Detects and rectifies faults implanted in motors, starters and protection equipment

2.2.2.6 Distribution System (20 hours)

(Transformer)

- Describes the maintenance checks required by a transformer

(Distribution)

- Explains what is meant by the following faults:
 - open-circuit
 - earth
 - short-circuit
- Estimates the current flowing during given fault conditions
- Explains how earth faults occur and the potential danger
- Explains the effects of an earth fault with an insulated distribution system
- Given a diagram showing earth-fault lamps, describe the appearance of the lamps when an earth fault occurs
- Explains the principle of using earth-fault instruments
- On a given distribution circuit, carries out a logical procedure to detect the location of an earth, using earth-fault lamps and an insulation-testing instrument
- Explains why the circuit must be switched off when replacing a lamp
- Describes the deterioration common in both lamp holders and their wire connections
- Explains the care necessary when working on fluorescent lamp circuits
- Describes how failed lamps are disposed of
- Describes the care necessary when maintaining:
 - exposed watertight fittings
 - portable hand lamps
- Carries out routine testing and maintenance of lighting circuits and fittings
- Detects and rectifies implanted faults likely to be encountered at sea (High voltage)
- States that high-voltage systems are normally earthed via a resistor
- Explains how the presence of earth faults is indicated in a high-voltage system with an earthed neutral
- States routine maintenances and inspection/testings to be needed

(Cables)

- Fits cables through glands into a terminal box, earthing the armouring as appropriate
- Solders and crimps terminal sockets to conductors
- Measures resistance of cables
- Explains the limitation of temporary repairs to insulation
- Carries out temporary repairs to insulation

2.2.2.7 D.C Electrical Systems and Equipment (5 hours)

(Battery system)

- States that emergency lights and backup power supply lines for the ship's propulsion machinery must be tested at frequent intervals
- Demonstrates or describes the maintenance of batteries, taking all necessary precautions
- Names the gases given off when recharging a lead-acid battery, explaining the effect on the electrolyte and how it is remedied
- Checks the specific gravity of the electrolyte of a lead-acid battery and of an alkaline battery and explains its significance

(Remote/Automatic Control Equipment)

- States that the presence of backup power for remote/automatic control equipment should be continuously monitored and must be checked at frequent intervals
- States how back up power for monitoring systems can be tested and its built-in battery must be renewed at a certain intervals
- States that backup power for safety/protective devices is supplied from emergency D.C. line and it must be tested carefully at a certain intervals
- States that the power for safety/protective devices is isolated from control systems and other power sources

2.2.3 DETECTION OF ELECTRIC MALFUNCTION AND MEASURES TO PREVENT DAMAGE (20 hours)

R1

Textbooks: T12, T28,
Teaching aids: A 1, A2, A3, V1

Required performance:

2.2.3.1 Fault Protection (15 hours)

- Explains why fault protection is essential
- Names the component parts of fault-protection equipment
- Explains why fault currents can be extremely high
- Names the three types of over current-protection relay and describes the principles of operation of each
- Explains the advantages and disadvantage of high-rupturing-capacity fuses
- Names the protection provided against:
 - short circuits
 - small overloads
- Describes the procedure when replacing a blown fuse
- Explains in simple terms, preferential tripping when overload occurs
- Explains the purpose of under voltage protection of generators and of motors
- Explains the purpose of reverse power protection
- Sketches the layout of a typical main switchboard, indicating the function of the main parts
- Explains the danger associated with the spaces in the vicinity of busbar

- Explains the use of transformers for switchboard instruments, stating the voltages and current produced
- Describes the earthing of instruments
- Explains the potential danger of instrument voltage/current transformer circuits and the safe procedure for working on such circuits
- Explains how status indicator lamps are usually supplied with power
- Describes the procedure if a fault develops with a miniature circuit breaker
- Describes the protection normally provided on the doors of switchboard cubicles
- Adjusts, maintains and tests the types of fault protection normally encountered

2.2.3.2 Fault Location (5 hours)

- Describes the essential requirements for the automatic operation of marine machinery
- Uses control and instrumentation terminology in its correct context
- Compares pneumatic, hydraulic and electronic-electrical control systems
- Describes a simple control loop
- Names analogue and digital devices
- Locates faults in simple control systems
- On locating fault takes actions to best prevent damage
- States what is necessary to prevent damage from electrical malfunctions such as burned circuit elements, poor contacts, breaking and faulty limit/micro switches

2.2.4 CONSTRUCTION AND OPERATION OF ELECTRICAL TESTING AND MEASURING EQUIPMENT (10 hours) R1

Textbooks: T12, T28,
Teaching aids: A 1, A2, A3, V1

Required performance:

(Insulation tester)

- States the operation principles of an insulation tester
- States the precautions when using an insulation tester
- States the range of voltages used for testing ships' equipment
- Uses an insulation tester:
 - to check the zero reading
 - to check that the equipment is dead
 - to measure values of phase-to-phase insulation
 - to measure values of phase-to-earth insulation

**STCW Code
B-III/1 pa.1**

(Continuity tester)

- Uses a continuity tester to:
 - check that the equipment is dead
 - measure the resistance of circuits
- Enters test readings and relevant comments on an appropriate record card
- Explains the significance of individual and comparative test readings

(Multi-tester)

- Uses digital and analogue multimeters, taking the necessary precautions, to:
 - check the accuracy of the meter
 - check for battery failure
 - measure resistance
 - measure voltage
 - measure current
 - test diodes

(Clampmeter)

- States the operation principles of a clampmeter
- States the precautions when using a clampmeter
- Uses a clampmeter to measure current
- Uses a live-line tester to determine whether equipment is live or dead

2.2.5 FUNCTION AND PERFORMANCE TEST AND CONFIGURATION (25 hours) R1

Textbooks: T12, T28, T72

Teaching aids: A1, A2, A3, V5

Required performance:

2.2.5.1 Monitoring Systems (5 hours)

- States what a monitoring system or data logger is
- Explains how a monitoring system is constructed showing its system configuration
- Explains roles of the following system components comprising a monitoring system:
 - CPU unit
 - I/O interface
 - monitoring display
 - log printer
 - telegraph logger
 - alarm printer
 - lamp driver
 - extension alarm system
- Explains briefly how each system component works and its operation mechanism
- Explains how measured/monitored values can be confirmed if it is correct
- Explains how alarm setting values in a monitoring system can be changed
- Explains how function/performance tests can be carried out taking a typical system as an example

2.2.5.2 Automatic Control Devices (10 hours)

(Process control)

- States what components comprise various automatic control systems showing their system configurations
- Explains briefly the roles/functions/performances of the following components and their operation mechanism:
 - sensor
 - transducer
 - controller
 - converter
 - positioner
 - regulator
 - control valve
 - actuator
 - relay
 - servomotor
- Explains what is meant by mechatronics and how it is utilized in automatic control systems
- Explains how function/performance tests for the each component cited above can be carried out
- Describes testing equipment for function/performance of the each component cited above

(System control)

- Describes how functions/performances of automatic control systems incorporated in the following operation systems can be tested
 - main engine
 - power generation and distribution
 - boiler
 - auxiliary machinery

2.2.5.3 Protective Devices (10 hours)

- States what is meant by protective/safety devices and how they work in simple terms
- Explains how protective/safety devices are incorporated in each system in a ship's propulsion machinery stating that protective/safety devices are isolated from their control systems
- Explains briefly the following protective/safety devices and operation mechanism
 - main engine shut down such as over speed, lubricating oil low pressure and etc.
 - prime mover of generator shut down
 - boiler shut down such as low water, non-detect flame eye and etc.
 - purifier shut down
- Describes briefly how functions/performances of protective/safety devices can be tested
- Explains the need for testing functions/performances of protective/safety devices in the ship's statutory survey

2.2.6 ELECTRICAL AND SIMPLE ELECTRONIC DIAGRAMS (5 hours) R1

Textbooks: T12, T28, T72

Teaching aids: A 1, A2, A3, V1

Required performance:

- Explains major electrical and electronic symbols used in their circuit diagrams
- Describes the function of circuit elements presented by the symbols in their circuit diagram
- Explains briefly the flow of electrical/electronic current and functions of their circuit diagrams taking simple circuits containing major electrical/electronic symbols as examples
- Explains the basic differences between the following electrical diagrams:
 - block
 - system
 - circuit
 - wiring
- Using a given simple wiring diagram, sketches a circuit diagram
- From given simple circuit or wiring diagrams, sketches schematic or system diagrams, using correct letter and circuit symbols
- Uses the diagrams named in the above objective

Officer in Charge of an Engineering Watch

Function 3:

Maintenance and Repair at the Operational Level

**Officer in Charge of an Engineering Watch
Function 3: Maintenance and Repair at the Operational Level**

INDEX

Part A3: Course Framework	103
Aims	
Objective	
Entry standards	
Course certificate	
Staff requirements	
Teaching facilities and equipment	
Teaching aids	
CDs&DVDs	
IMO references	
Textbooks	
Part B3: Course Outline and Guidance Notes	106
Timetable	
Lectures	
Course outline	
Guidance notes	
Part C3: Detailed Teaching Syllabus	118
Introduction	
Explanation of information contained in the syllabus tables	
3.1 Maintenance of marine engineering systems, including control systems	

Function 3 - Maintenance and Repair at the Operational Level

Part A3: Course Framework

Aims

This model course aims to meet the mandatory minimum requirements for knowledge, understanding and proficiency in Table A-III/1 of STCW 2010 for the function "Maintenance and Repair at the Operational Level".

Objective

This syllabus covers the requirements of the STCW 2010 Convention Chapter III, Section A-III/1. This functional element provides the detailed knowledge to support the training outcomes related to Maintenance and Repair at the Operational Level.

This section provides the background knowledge and practical work to support:

- the use of hand and machine tools and measuring instruments
- marine engineering maintenance

Entry standards

This course is principally intended for candidates for certification as officer in charge of an engineering watch in a manned engine-room or designated duty engineers in a periodically unmanned engine-room. Those wishing to enter this course should be following an approved programme of on-board training.

Course certificate

On successful completion of the course and assessments, a document may be issued certifying that the holder has successfully completed a course of training which meets or exceeds the level of knowledge and competence specified in Table A-III/1 of STCW 2010, for the function "Maintenance and Repair at the Operational Level".

Staff requirements

Instructors shall be qualified for the task for which training is being conducted and have appropriate training in instructional techniques and training methods (STCW Code Section A-I/6). Depending on the complexity of the exercises an assistant instructor with similar experience is desirable for certain practical exercises.

Teaching facilities and equipment

A workshop is required equipped with an overhead crane and a range of maintenance tools. Services such as compressed air and a water supply will be necessary, as well as access to workshops used for training in other marine engineering skills.

A classroom equipped with an overhead projector and a blackboard, whiteboard or flipchart should be provided for teaching the theory of the course, holding group discussions and writing reports.

When starting a training programme in plant maintenance in a training institute, the acquisition of suitable marine engineering components and machinery can be difficult as the high cost would preclude the purchase of new equipment. The training centre can initially acquire scrap, discarded parts and equipment items, or seek donations of equipment from manufacturers or shipowners. Some financial annual provision must be made in the training centre's budget for updating and expanding the equipment each year.

The following equipment is recommended:

- pumps
- air compressors
- steam turbine

- diesel engine four and two stroke
- a wide range of valves
- pipework and fittings
- refrigerator components
- heat exchangers
- boiler mountings
- oil fuel burners
- deck machinery
- diesel engine cylinder heads, complete with fittings
- hydraulic pumps, motors, valves and fittings
- a turbocharger
- a thrust block
- oil purifiers

Teaching aids (A)

A1 Instructor Guidance (Part B of this course)

A2 Manufacturer's Manuals

Manufacturers' instruction manuals and handbooks are the main source of information in instructing the correct procedures in dismantling, inspection and assembly of the specific items of machinery listed.

A3 Video cassette player/ DVD player, personal computer

CDs & DVDs

V1 Welding safety (Code No. 495)

V2 Who needs it? Personal protective equipment (Code No. 597)

V3 Entry into enclosed spaces (Code No. 534)

V4 Permit to work (Code No. 621)

V5 Personal safety in the engine-room (Code No. 556)

Available from: Videotel Marine International Ltd.,
84 Newman Street, London W1 P 3LD, UK
Tel : 44 20 7299 1800
Fax: 44 20 7299 1818
e-mail: mail@videotelmail.com
URL: www.videotel.co.uk

IMO references (R)

R1 International Convention on Standards of Training, Certification and Watchkeeping for Seafarers (STCW), 1998 (IMO Sales No. 938), 1997 Amendments to STCW 95 (IMO Sales No. 945), and 2010 Amendments to STCW 95

R2 International Convention for the Safety of Life at Sea, 1974, as amended (SOLAS) (IMO Sales No. 110)

R5 International Safety Management Code (ISM Code) (IMO-186)

Details of distributors of IMO publications that maintain a permanent stock of all IMO publications may be found on the IMO web site at <http://www.imo.org>

Textbooks (T)

- T7 Flood, C.R. Fabrication, Welding and Metal Joining Processes. London, Butterworth, 1981 (ISBN 04-08-00448-7) OUT OF PRINT 1999
- T13 Hannah-Hillier, J. Applied Mechanics. Harlow, Longmann. 1995. (ISBN 05-82-25632-1)
- T24 Jackson, L and Morton, T.D. General Engineering Knowledge for Marine Engineers. 5th ed. London, Thomas Reed Publications Ltd 1990. (ISBN 09-47-63776-1)
- T41 Pritchard, R.T. Technician Workshop Processes and Materials. London, Hodder and Stoughton, 1979 (ISBN 0-34022-100-3) OUT OF PRINT 1999
- T46 Simmonds, C.H. and Maguire, D.E. Progressive Engineering Drawing for T.E.C. Students, London. Hodder and Stoughton Ltd 1983 (ISBN 03-40-26196-x-0) OUT OF PRINT 1999
- T50 Talor, D.A. Introduction to Marine Engineering. 2nd ed. London, Butterworth.1990 (ISBN 07-50-6253-9)
- T70 Code of Safe Working Practices for Merchant Seamen, London. The Stationery Office Publications Centre, 1998 (ISBN 0115518363)

Secondhand copies of out of print books may be available from the Warsash Nautical Bookshop, 6 Dibles Road, Warsash, Southampton SO31 9HZ, UK. Tel: 44 1489 572 384 Fax: 44 1489 885756
E-mail: orders@nauticalbooks.co.uk URL: www.nauticalbooks.co.uk

Function 3 - Maintenance and Repair at the Operational Level

Part B3: Course Outline and Guidance Notes

Timetable

No formal example of a timetable is included in this model course.

Development of a detailed timetable depends on the level of skills of the trainees entering the course and the amount of revision work of basic principles that may be required.

Lecturers must develop their own timetable depending on:

- the level of skills of trainees
- the numbers to be trained
- the number of instructors

and normal practices at the training establishment.

Preparation and planning constitute an important factor which makes a major contribution to the effective presentation of any course of instruction.

Lectures

As far as possible, lectures should be presented within a familiar context and should make use of practical examples. They should be well illustrated with diagrams, photographs and charts where appropriate, and be related to matter learned during seagoing time.

An effective manner of presentation is to develop a technique of giving information and then reinforcing it. For example, first tell the trainees briefly what you are going to present to them; then cover the topic in detail; and, finally, summarize what you have told them. The use of an overhead projector and the distribution of copies of the transparencies as trainees handouts contribute to the learning process.

Course Outline

The tables that follow list the competencies and areas of knowledge, understanding and proficiency, together with the estimated total hour enquired for lectures and practical exercises. Teaching staff should note that timings are suggestions only and should be adapted to suit individual groups of trainees depending on their experience, ability, equipment and staff available for training.

COURSE OUTLINE

Knowledge, understanding and proficiency	Total hours for each topic	Total hours for each subject area of Required performance
Competence		
3.1	APPROPRIATE USE OF HAND TOOLS, MACHINE TOOLS AND MEASURING INSTRUMENTS FOR FABRICATION AND REPAIR ON BOARD (184 hours)	
3.1.1	CHARACTERISTICS AND LIMITATIONS OF MATERIALS USED IN CONSTRUCTION AND REPAIR OF SHIPS AND EQUIPMENT (15 hours)	
	.1 Basic Metallurgy, Metals and Processes (6 hours)	
	.2 Properties and Uses (6 hours)	
	.3 Non-Metallic Materials (3 hours)	
3.1.2	CHARACTERISTICS AND LIMITATIONS OF PROCESS USED FOR FABRICATION AND REPAIR (10 hours)	
	.1 Process (5 hours)	
	.2 Heat Treatment of Carbon Steel (5 hours)	
3.1.3	PROPERTIES AND PARAMETERS CONSIDERED IN THE FABRICATION AND REPAIR OF SYSTEMS AND COMPONENTS (19 hours)	
	.1 Materials Under Load (5 hours)	
	.2 Vibration (3 hours)	
	.3 Self-Secured Joints (1 hour)	
	.4 Permanent Joints (1 hour)	
	.5 Bonding Plastics (1 hour)	
	.6 Adhesives and Bonding (3 hours)	
	.7 Pipework (5 hours)	
3.1.4	METHODS FOR CARRYING OUT SAFE EMERGENCY/TEMPORARY REPAIRS (5 hours)	
3.1.5	SAFETY MEASURES TO BE TAKEN TO ENSURE A SAFE WORKING ENVIRONMENT AND FOR USING HAND TOOLS, MACHINE TOOLS AND MEASURING INSTRUMENTS (5 hours)	
3.1.6	USE OF HAND TOOLS, MACHINE TOOLS AND MEASURING INSTRUMENTS (125 hours)	
	.1 Hand Tools (15 hours)	
	.2 Powered Hand Tools (5 hours)	
	.3 Machine Tools (95 hours)	
	.4 Measuring Instruments (10 hours)	
3.1.7	USE OF VARIOUS TYPES OF SEALANTS AND PACKINGS (5 hours)	
3.2	MAINTENANCE AND REPAIR OF SHIPBOARD MACHINERY AND EQUIPMENT(218 hours)	

- 3.2.1 SAFETY MEASURES TO BE TAKEN FOR REPAIR AND MAINTENANCE INCLUDING THE SAFE ISOLATION OF SHIPBOARD MACHINERY AND EQUIPMENT REQUIRED BEFORE PERSONNEL ARE PERMITTED TO WORK ON SUCH MACHINERY OR EQUIPMENT (5 hours)**
- .1 ISM Code (1 hour)
 - .2 SMS (2 hours)
 - .3 Safety Measures to be Taken (2 hours)
- 3.2.2 APPROPRIATE BASIC MECHANICAL KNOWLEDGE AND SKILLS (5 hours)**
- 3.2.3 MAINTENANCE AND REPAIR SUCH AS DISMANTLING, ADJUSTMENT AND REASSEMBLING OF MACHINERY AND EQUIPMENT (145 hours)**
- .1 Fastening
 - .2 Centrifugal Pumps
 - .3 Reciprocating Pumps
 - .4 Screw and Gear Pumps
 - .5 Valves
 - .6 Air Compressors
 - .7 Heat Exchangers
 - .8 Diesel Engine
 - .9 Turbocharger
 - .10 Boiler
 - .11 Maintenance Propulsion Shafting Procedures
 - .12 Refrigeration Maintenance
 - .13 Oils Fuels and Lubricating System Maintenance
 - .14 Deck Machinery Maintenance
- 3.2.4 THE USE OF APPROPRIATE SPECIALIZED TOOLS AND MEASURING INSTRUMENTS (5 hours)**
- 3.2.5 DESIGN CHARACTERISTICS AND SELECTION OF MATERIALS IN CONSTRUCTION OF EQUIPMENT (15 hours)**
- .1 Selection of Materials in Construction of Equipment (6 hours)
 - .2 Design Characteristics (6 hours)
 - .3 Design Characteristics of Bearings (3 hours)
- 3.2.6 INTERPRETATION OF MACHINERY DRAWINGS AND HANDBOOKS MARINE ENGINEERING DRAWING AND DESIGN (38 hours)**
- .1 Types of Drawing (2 hours)
 - .2 Linework (4 hours)
 - .3 Pictorial Projection (4 hours)
 - .4 Development (4 hours)
 - .5 Dimensioning (5 hours)
 - .6 Geometrical Tolerancing (2 hours)
 - .7 Limits and Fits (2 hours)
 - .8 Engineering Drawing Practice (15 hours)
- 3.2.7 THE INTERPRETATION OF PIPING, HYDRAULIC AND PNEUMATIC DIAGRAMS (5 hours)**

Total for Funston 3: Maintenance and Repair at the Operational Level 400 hours

Guidance Notes

The following notes are intended to highlight the main objectives or training outcomes of each part of the function. The notes also contain some material on topics which are not adequately covered in the quoted references.

This function is extensive and covers many different areas, including: properties and characteristics of materials in propulsion machinery; emergency/temporary repairs; safety measures; hand and machine tools and measuring instruments; maintenance and repairs of propulsion machinery; engineering drawings; piping, hydraulic and pneumatic diagrams.

Trainees will acquire practical skills and gain experience in:

- the use of hand and machine tools, and measuring instruments;
- using and wearing correct protective clothing and equipment;
- maintenance and repairs of propulsion machinery including proper dismantling/reassembling procedures, proper use of sealants and packings, specialized tools and measuring instrument, inspection and test running;
- making engineering drawings of simple components of machinery.

Function 3: Maintenance and Repair at the Operational Level

Before any work commences, trainees should receive clear instructions about the job in hand. This could take place in a classroom but often it is appropriate and more convenient to do this in the workshop. Job cards should be prepared giving information and instruction together with the questions and the data required.

Whilst the work is in progress and after completion, sketches will need to be made and a report, with recommendations, drawn up.

3.1 APPROPRIATE USE OF HAND TOOLS, MACHINE TOOLS AND MEASURING INSTRUMENTS FOR FABRICATION AND REPAIR ON BOARD

3.1.1 CHARACTERISTICS AND LIMITATIONS OF MATERIALS USED IN CONSTRUCTION AND REPAIR OF SHIPS AND EQUIPMENT

Basic Metallurgy, Metals and Processes

Trainees were introduced to marine engineering materials, in pre-requisites at the time they were acquiring basic engineering skills. The purpose of this training outcome is to increase the trainees' knowledge of materials sufficiently to carry out the duties of a watchkeeping engineer. The topics are therefore limited in depth, as indicated by the training outcomes, which need not be exceeded.

Trainees will not be involved in the manufacture of any metals, but some knowledge of the production processes is necessary in order to understand the behaviour and performance of materials in operational conditions.

It is sufficient to refer to the basic constituents, relative strengths, resistance to corrosion, weldability, magnetic properties and electrical conduction properties of materials.

Properties and Uses

The graph in textbook T24 could be used as a helpful reference but note that the training outcome referring to ductility, tensile stress etc. simply requires a comparison of those named properties of three kinds of carbon steel.

If small samples of the various metals are not available, then trainees will need to identify those materials from colour photographs or, preferably, by examining machinery and components.

Non-Metallic Materials

Trainees should be made aware that the variety of plastics available is increasing rapidly; therefore only the basic properties and reactions are covered.

3.1.2 CHARACTERISTICS AND LIMITATIONS OF PROCESS USED FOR FABRICATION AND REPAIR

Process

For training outcome Processes, it is suggested that examples such as heat treatment of knives, chisels, files, saws and drills are used.

3.1.3 PROPERTIES AND PARAMETERS CONSIDERED IN THE FABRICATION AND REPAIR OF SYSTEMS AND COMPONENTS

Vibration

Vibration is covered to a level which requires trainees to be able to state or describe various aspects of the source and effects of shipboard vibration. The topic has not been extended to include any theory as this tends to become too academic without being beneficial to a watchkeeping engineer.

Instructors should note that trainees at this level are not likely to be familiar with the theory of dynamic balancing of rotational forces. Nevertheless, they should be able to cope with the concept of unbalanced rotational and reciprocating forces, having observed the effect of these. Trainees should learn that anything which creates an imbalance in a rotating mass will produce vibration. Also that the removal of uneven deposits on rotating components normally restores balance.

Instructors should indicate to trainees that machinery mounting pads are good examples of a means of reducing the transmission of vibrations.

Instructors should indicate to trainees that torsional vibrations can occur within components and are not always transmitted to either the engine frame or the ship structure. Critical speed ranges designated by designers are speeds where dangerous vibrations occur and might not be apparent; therefore they should be avoided. Designers attempt to avoid a critical speed occurring in the normal operating range, but sometimes this is unavoidable. These problems have been known to cause crankshaft failures.

Instructors should indicate to trainees that it may be necessary to change over to stand-by machinery while the cause of vibration is investigated. Attention to stays, pipe clips and other means of securing components and also removing deposits from impellers etc., or renewing worn bearings often reduces vibration.

Self-Secured Joints

Trainees may have to repair items at sea incorporating self-secured joints.

Bonding Plastics

It is impossible to cover all available plastics, but the main principles can be studied.

Pipework

Trainees will most certainly have to bend copper pipes on board ship and, in extenuating circumstances, could have to bend mild steel pipes.

Training outcome Heat Treatment is in Hand and Power Tools, but there the treatment is principally applied to tools whereas training outcome Annealing and Normalizes applies to pipes etc.

3.1.4 METHODS FOR CARRYING OUT SAFE EMERGENCY/TEMPORARY REPAIRS

Emergency/temporary repairs on board ships are sometime necessary in case of water leakage, oil leakage, gas leakage and the like. Trainees therefore need to learn how to address these situations including case studies and materials made available.

3.1.5 SAFETY MEASURES TO BE TAKEN TO ENSURE A SAFE WORKING ENVIRONMENT AND FOR USING HAND TOOLS, MACHINE TOOLS AND MEASURING INSTRUMENTS

Safety measures to be taken should be taught before working on tasks using all kinds of tools and measuring instruments. Trainees should learn about safety precautions, dangers caused by the features of hand tools, powered hand tools and machine tools when using such tools, and the need to keep tools in good order.

3.1.6 USE OF HAND TOOLS, MACHINE TOOLS AND MEASURING INSTRUMENTS

In this section trainees will acquire practical skills and gain experience in:

- using hand and machine tools and measuring instruments for fabrication, maintenance and repair;
- the maintenance of tools and measuring instruments to be in good order and ready to use;
- selecting the correct tools and measuring instruments;
- using safe practices at all times;
- wearing and using proper protective clothing and equipment.

On completion of this section, trainees will possess sufficient skill and knowledge in the use of hand and power tools to carry out and/or supervise the work normally encountered as maintenance or repair work on board ship. Trainees will be able to select and use the correct tools in any given situation and carry out the necessary maintenance to ensure that they are kept in good order and ready for use. Trainees will also know how to apply the correct heat treatment to carbon steels in order to manufacture or repair simple tools. They will be able to select and use the correct adhesives for bonding of metals and plastics.

Hand Tools

In the workshop or classroom, each hand tool should be shown to trainees and demonstrated how to use the tools and their purposes. Appropriate materials should be provided for trainees in order to develop skills in using hand tools.

Powered Hand Tools

The common powered hand tools on board ship are electrically driven drilling, grinding and shear machines. Trainees need to be able to use these powered hand tools and opportunities should be given to acquire skills in using these tools in the workshop.

Machine Tools (Centre Lathe)

Safe working practices are to be applied at all times.

To satisfy training outcome for centre lathe, trainees will see a guide mechanism probably for the first time. As similar systems are used in various applications on board ship, it is important that particular attention is paid. In addition, it should be explained that cast iron is sometimes used on board ship where machinability and rigidity are required, for example in machinery foundations such as pumps, winches or small engine bedplates.

There is no need for trainees to be able to sketch lathes etc., but there is a need to be able to identify various features.

On board ship, speed of machining might not be the prime criterion, but preservation of the geometry of the workpiece usually is important. Trainees should be able to plan and perform one setting operation for simple jobs.

Many ships have shaping machines installed; very few have milling machines. Most manufacturing or repair work on board ship can be accomplished without a milling machine and the expense of installing such a machine is often considered not justified. It is important, therefore, that trainees become skilful in the versatility of a shaping machine. (Ref. STCW 2010 Code Chapter III Sec. B-III/4)

(Soldering)

Practical soldering will also be covered in training outcomes within Marine Electrotechnology. Applications should be restricted to sheet work and to pipe work within these training outcomes.

(Safety and Health when Welding)

It is not necessary to cover the additional protection referred to in Protective Measures in detail.

(Principles of Arc Welding)

Trainees will learn how to weld low-carbon steels and need to be aware of the problems of welding steels with higher carbon contents.

(Principles of Gas Welding)

Trainees need to know the technique of tungsten inert-gas (TIG) and MIG welding, but not necessarily be competent to carry out TIG and MIG welding.

It is possible that a low-pressure system, supplied by several cylinders discharging into a manifold, might be installed in the training establishment. On board ship a high-pressure system, fed from two gas cylinders, is likely to be used and training outcome **High-pressure blow pipe**, which is unsuitable for low-pressure systems, is intended to clarify the different equipment required.

Acetylene is probably the gas available on board ship, but trainees need to be aware of other gases.

(Thermal Cutting)

Plasma arc cutting is included so that trainees will be aware of it; the process will not be used personally by trainees on board ship.

(Inspection)

Training outcome Inspection has been included because inspection of welding work is often a very important part of an engineer officer's duties.

Measuring Instruments

Trainees need to learn how to use measuring instruments for carrying out fabrication, maintenance and repair. Particularly the use of various vernier callipers, micrometers and dial indicators need to be learned since these are usually used as precision instrument on board ships.

3.1.7 USE OF VARIOUS TYPES OF SEALANTS AND PACKINGS

Trainees need to know about sealants and packings including their definition and effects.

3.2 MAINTENANCE AND REPAIR OF SHIPBOARD MACHINERY AND EQUIPMENT

3.2.1 SAFETY MEASURES TO BE TAKEN FOR REPAIR AND MAINTENANCE INCLUDING THE SAFE ISOLATION OF SHIPBOARD MACHINERY AND EQUIPMENT REQUIRED BEFORE PERSONNEL ARE PERMITTED TO WORK ON SUCH MACHINERY OR EQUIPMENT

Every topic will require instructions and guidance before practical work commences. Each time, opportunity should be taken to ensure that safe operation remains prominent in every process.

The potential hazards present in a workshop cannot be over-emphasized. It is essential that trainees are fully aware of the dangers and the precautions necessary before commencing any activity. The main issue is to ensure that trainees consider the aspects of safety and care as an integral part of everything they do.

The ship's safety management system should provide safe practices in ship operation and a safe working environment, with safeguards against all identified risks in compliance with the ISM Code (R5).

Safety precautions, rules and practices may also be found in T70 and these topics are addressed in V1, V2 and V5

3.2.2 APPROPRIATE BASIC MECHANICAL KNOWLEDGE AND SKILLS

Trainees need to learn about basic mechanical knowledge concerning construction and operation mechanisms of ship's machinery and to acquire basic skills in order to carry out their maintenance and repair. This knowledge and skills can be referred to Function 1 with the understanding mentioned in this section.

3.2.3 MAINTENANCE AND REPAIR SUCH AS DISMANTLING, ADJUSTMENT AND REASSEMBLING OF MACHINERY AND EQUIPMENT

The programme of practical training is progressive. The early part should cover the acquisition of skills such as the use of hand tools, machine tools, welding, etc.; the later part is concerned with the techniques of inspection, maintenance and repair.

It is necessary to complete basic skills first, before commencing the remainder of the work.

An adequate knowledge and understanding of the procedures necessary to maintain marine machinery installations in a safe and efficient working order can only be obtained through actual experience.

To ensure that all aspects are covered, and a good understanding is gained, training must be under close supervision and should consist of a progressive and controlled series of activities and projects.

As well as instructing trainees in the classroom, it is advisable to reinforce matters such as safe practice immediately before starting and at frequent intervals during practical work. Posters relating to safe practices are sometimes available from Administrations and video recordings or films, if available on similar subjects, can be useful.

First-aid equipment and staff trained in first aid should always be available when trainees are in workshops. There should also be a means of transport and communication available for emergency use in case of an accident.

It is important that trainees achieve the training outcomes. However, the order in which these are accomplished is not important. In some cases it will be necessary to rearrange the order printed in the syllabus to accommodate the sequence dictated by a particular job. In all cases, it must be ensured that trainees are competent in basic skills before proceeding to more advanced work.

Plant maintenance training should include, wherever possible, lectures and discussions covering:

- the basic principles of the components to be worked on;
- the application of safe practices at all times;
- the isolation of units and/or systems prior to dismantling;
- the security of all personnel and materials during a maintenance operation;
- the dangers inherent in systems which contain fluids under pressure, or are of a hazardous nature;
- the basics of maintenance technology in terms of:
 - planned maintenance systems
 - condition monitoring
 - diagnostic testing
 - preventative maintenance
 - predictive maintenance

In the training utilizing the equipment/facilities in the work shop, the instructor should set up training exercises to be done by trainees so as to make full use and consideration of their features.

At all times trainees should wear adequate protective clothing and footwear appropriate to the work in hand. Safe working practices should be enforced at all times, see video V3. It is important that training objectives are achieved during this part of the course. Most of the training outcomes will, as a natural outcome, be covered several times in various forms and applications.

3.2.4 THE USE OF APPROPRIATE SPECIALIZED TOOLS AND MEASURING INSTRUMENTS

Major installations on board ships have specialized tools and measuring instruments for their maintenance and repair. These tools and instruments have special shapes to apply only to their specific installations. Trainees need to learn about what sort of tools and instruments are available and how to use them.

3.2.5 DESIGN CHARACTERISTICS AND SELECTION OF MATERIALS IN CONSTRUCTION OF EQUIPMENT

Materials in Construction of Equipment

Suitable materials are to be used to construct ship's machinery installations and trainees need to learn the features of the materials in specific parts of the installations in terms of strength, corrosion and other aspects. The first part of this function can also be applied.

Design Characteristics of Bearing

Trainees need to learn about basic design characteristics to understand what improvements in the design of ship's machinery installations have been made to improve performance. The first part of this function can also be applied.

Bearings

All types of bearings are used on board ship and a marine engineer spends considerable time on their inspection, maintenance and renewal. Bearings are also dealt with both practically and theoretically in other training outcomes, and there is therefore no need to exceed the training outcome requirements.

Large, thin-walled or shell bearings are in common use in modern large-bore diesel engines. The shell of such a bearing might be 600 mm in diameter and 15 mm thick.

In general, it can be said that in marine practice ball and roller bearings are used for small diameter applications such as in electric motors, etc.; they are also used for turbo-charger rotors. Although not directly part of this subject, the opportunity should be taken to make trainees aware of the need, in the case of certain high-speed applications, to renew bearings when the running hours prescribed by the manufacturer have been reached.

Trainees should not be expected to give details of which types of bearing are suitable for given applications; however, evidence of awareness of different bearings for different conditions is essential.

Lubrication of Ball and Roller Bearings

Bear in mind that lubricating oil is dealt with elsewhere in the course. In addition to this objective, the lubrication of ball and roller bearings is covered briefly in other training outcomes.

Lubrication in general is covered elsewhere but the question of maximum quantities to be used in ball and roller bearings is unique to training outcome, Lubrication of ball and roller bearings.

3.2.6 INTERPRETATION OF MACHINERY DRAWINGS AND HANDBOOKS MARINE ENGINEERING DRAWING AND DESIGN

On completion of this section, trainees will be competent to obtain any required information from engineering drawings produced to international standards and conventions. Should the need arise they will also be able to produce drawings of an adequate standard to manufacture of equipment components. In addition, they will possess knowledge of design principles.

Types of Drawing

A marine engineer officer is a user of drawings; he has to be competent in reading drawings so as to carry out maintenance, repair, identification of components and their replacement. From time to time replacements will have to be made on board ship or ashore, either from original drawings supplied to the ship or occasionally from engineering drawings or sketches produced on board. It is not necessary, therefore, for trainees to become expert draughtsmen but they do require a thorough understanding of drawings and they also should have the ability to produce sketches and, if necessary, engineering drawings for use by others.

In addition to being able to obtain information from drawings, a marine engineer should have a good understanding of design concepts. This will assist in decision-making processes. For example, when machinery is malfunctioning it is often necessary to consider the possible design principles as part of an analysis of the problem as a basis for correcting the fault.

Linework

Engineering Drawing Practice appears in the syllabus as the last subject area, and it carries a time allocation of 15 hours. This does not mean that actual drawing should be delayed until the end; in fact there is much to be gained from trainees producing drawings from the early stages of the subject, for example, as required in Linework. The production of engineering drawings should be a continuing part of the training outcomes, with successive drawings including newly covered topics as the work progresses. In a similar manner the time allocated to various topics is mutually interchangeable according to how the instructor envisages his teaching plan.

Useful and meaningful exercises would be to produce drawings from which trainees can manufacture items as part of the engineering workshop skills.

Linework is the introduction to drawing skills. Trainees should be encouraged to use correct linework right from the beginning

Discretion should be used when teaching the drawing of tangents. Trainees will need to draw tangents when producing drawings but they are not expected to become expert draughtsman. They need to become aware of the special care necessary so that when the time comes they can refer to the method required.

Both of the projection styles mentioned in the training outcomes are in common use and it is therefore very important that trainees establish the method used before taking information

from drawings. The level of examples given in the book reference against the training outcome is adequate and should not be exceeded.

Trainees should not be expected to produce auxiliary views but they do need to know what they are and to be competent to obtain information from them.

Pictorial Projection

Instructors are referred to the recommended textbooks for guidance. In this area the use of simple CAD programs may be introduced.

Development

Development has been kept as simple as possible so as to obtain an insight into the principles. If, later during their career, trainees have to produce development drawings they will need to build on the principles.

Dimensioning

Instructors are referred to the recommended textbook, T46 for guidance.

Geometrical Tolerancing

It is unlikely that trainees will use geometrical tolerances, but they will see such references on drawings, and they therefore need to know their meaning.

Limits and Fits

The interchangeability of spare parts is very important. Spare parts may have to be obtained from a variety of sources and may, in some cases, have to be manufactured on board ship. A marine engineer must therefore be familiar with the allowable tolerances which might apply to components.

Trainees should not be expected to select fits but they need to know that the information is available. They should be able to quote the approximate dimensions.

Engineering Drawing Practice

Although engineering drawing practice appears last, it is expected that trainees will have been producing drawings throughout the training outcomes for this area. The purpose of engineering drawing practice is to specify the work which needs to be included. The examples printed in textbook T46 are adequate to cover the training outcome. However, instructors may wish to add others more obviously associated with marine engineering. This being so, consideration should be given to the possibility of including drawings of components and machinery situated in the college's marine engineering maintenance or operations workshops.

3.2.7 THE INTERPRETATION OF PIPING, HYDRAULIC AND PNEUMATIC DIAGRAMS

As aforementioned, understanding engineering drawings and obtaining necessary information from them are essential abilities for trainees and the symbols used in these diagrams should be taught as part of the training to interpret an engineering drawing.

Part C3: Detailed Teaching Syllabus

Introduction

The detailed teaching syllabus is presented as a series of learning objectives. The objective, therefore, describes what the trainee must do to demonstrate that the proficiency in specified knowledge or skill has been acquired.

Thus each training outcome is supported by a number of related performance elements in which the trainee is required to be proficient. The teaching syllabus shows the *Required performance* expected of the trainee in the tables that follow.

In order to assist the instructor, references are shown to indicate IMO references and publications, textbooks and teaching aids that instructors may wish to use in preparing and presenting their lessons.

The material listed in the course framework has been used to structure the detailed teaching syllabus; in particular,

Teaching aids (indicated by A);
IMO references (indicated by R); and
Textbooks (indicated by T),

will provide valuable information to instructors.

Explanation of Information Contained in the Syllabus Tables

The information in each table is systematically organized in the following way. The line at the top of the table describes the FUNCTION with which the training is concerned. A function means a group of tasks, duties and responsibilities as specified in the STCW Code. It describes related activities which make up a professional discipline or traditional departmental responsibility on board.

In this Model course there are four functions:

Marine engineering at the operational level
Electrical, electronic and control engineering at the operational level
Maintenance and repair at the operational level
Controlling the operation of the ship and care for the persons on board at the operational level.

The header of the first column denotes the COMPETENCE concerned. Each function comprises a number of competences. For example, the Function 3, "Maintenance and Repair at the Operational Level", comprises two competences and requirements "knowledge, understanding and proficiency" for each competence are uniquely and consistently numbered in this model course.

In this function, two competences are set up, which are "Appropriate use of hand tools and measuring instruments for fabrications and repair on board" and "Maintenance and repair of shipboard machinery and equipment". The former was mentioned under Function 1 in the previous version of this model course.

Finally, each training outcome embodies a variable number of "Required performances" as evidence of competence. The instruction, training and learning should lead to the trainee meeting the specified "Required performance". For the training outcome "Characteristics and limitation of materials used in construction and repair of ships and equipment", there are three areas of performance. For example:

3.1.1.1 Basic Metallurgy, Metals and Processes

3.1.1.2 Properties and Uses

- Describes in simple terms the production of pig iron from iron ore
- Describes the principles of the open-hearth, the Bessemer and more modern processes used in the production of steel from pig iron
- Explains the principal differences between sand casting, die casting, centrifugal casting, forgings, cold working and hot-rolled plate, bars and other sections and so on.

IMO references (Rx) are listed in the column to the right hand side. Teaching aids (Ax), videos (Vx) and textbooks (Tx) relevant to the training outcome and required performances are placed immediately following the TRAINING OUTCOME title.

It is not intended that lessons are organized to follow the sequence of "Required performances" listed in the Tables. The Syllabus Tables are organized to match with the competence in the STCW Code TableA-III/1. Lessons and teaching should follow college practices. It is not necessary, for example, for Materials for construction and repair to be studied before Safe working practices. What is necessary is that all the material is covered and that teaching is effective to allow trainees to meet the standard of the "Required performance".

COMPETENCE 3.1	Appropriate use of hand tools, machine tools and measuring instruments for fabrication and repair on board	IMO Reference
----------------	------------------------------------------------------------------------------------------------------------	---------------

TRAINING OUTCOMES:

Demonstrates a knowledge and understanding of :

STCW CODE
Table A-III/1

- 3.1.1 CHARACTERISTICS AND LIMITATIONS OF MATERIALS USED IN CONSTRUCTION AND REPAIR OF SHIPS AND EQUIPMENT**
- 3.1.2 CHARACTERISTICS AND LIMITATIONS OF PROCESSES USED FOR FABRICATION AND REPAIR**
- 3.1.3 PROPERTIES AND PARAMETERS CONSIDERED IN THE FABRICATION AND REPAIR OF SYSTEMS AND COMPONENTS**
- 3.1.4 METHODS FOR CARRYING OUT SAFE EMERGENCY/TEMPORARY REPAIRS**
- 3.1.5 SAFETY MEASURES TO BE TAKEN TO ENSURE A SAFE WORKING ENVIRONMENT AND FOR USING HAND TOOLS, MACHINE TOOLS AND MEASURING INSTRUMENTS**
- 3.1.6 USE OF HAND TOOLS, MACHINE TOOLS AND MEASURING INSTRUMENTS**
- 3.1.7 USE OF VARIOUS TYPES OF SEALANTS AND PACKINGS**

COMPETENCE 3.1	Appropriate use of hand tools, machine tools and measuring instruments for fabrication and repair on board	IMO Reference
----------------	------------------------------------------------------------------------------------------------------------	---------------

3.1.1 CHARACTERISTICS AND LIMITATIONS OF MATERIALS USED IN CONSTRUCTION AND REPAIR OF SHIPS AND EQUIPMENT (15 hours)

Textbooks: T13, T24
Teaching aids: A 1

Required performance:

3.1.1.1 Basic Metallurgy, Metals and Processes (6 hours) R1

- Describes in simple terms the production of pig iron from iron ore
- Describes the principles of the open-hearth, the Bessemer and more modern processes used in the production of steel from pig iron
- Explains the principal differences between sand casting, die casting, centrifugal casting, forgings, cold working and hot-rolled plate, bars and other sections
- States the normal range of carbon content in mild steel, tool steel, cast steel and cast iron
- Describes the principle difference between ferrous and non-ferrous metals
- Gives examples of applications of non-ferrous metals in marine engineering
- States the purpose of the alloying elements nickel, chromium and molybdenum in steels used in marine engineering
- Identifies the metals used in non-ferrous alloys commonly employed in Marine engineering

3.1.1.2 Properties and Uses (6 hours) R1

- Explains in simple terms what influences the choice of material for a marine engineering component
- Describe in simple terms what is meant by the following mechanical properties:
 - elasticity
 - brittleness
 - hardness
 - strength
 - toughness
 - ductility
 - malleability
 - plasticity
- Explains what is meant by low-, medium-and high-carbon steels
- Compares the tensile strength, ductility and hardness of low-, medium-and high-carbon steels
- States the uses of low-, medium and high-carbon steels
- Describes the properties of cast iron and gives examples of its use
- Defines an alloy
- States the uses of aluminium, copper, zinc, lead, tin and antimony
- States the component metals of brass, bronze and white metal
- States the uses of the above alloys
- Explains why the above alloys are suitable for the uses in the above objective
- Identifies samples of metals described in the above objectives

3.1.1.3 Non-Metallic Materials (3 hours) R1

- Explains the reasons for using the following fillers in polymers:
 - glass fibre
 - mica

- States that polymers can be plastic, rigid, semi-rigid or elastomeric
- States the properties and limitations of polymers
- Lists polymers and other non-metallic materials in common use
- States applications of polymers and other non-metallic materials on board ship

3.1.2 CHARACTERISTICS AND LIMITATIONS OF PROCESSES USED FOR FABRICATION AND REPAIR (10 hours)

Textbooks: T7, T24, T41
Teaching aids: A 1

Required performance:

3.1.2.1 Process (5 hours)

R1

- Describe, in basic terms, the following heat-treatment processes:
 - tempering
 - annealing
 - normalizing
 - hardening
- Explains, and indicates why the processes in the above objective are used
- States how low-carbon steels can be cases hardened
- States why low-carbon steels are sometimes cases hardened
- Describes in basic terms a suitable heat-treatment process for common carbon steels, given the properties required

3.1.2.2 Heat Treatment of Carbon Steel (5 hours)

- Explains the purpose of heat treatment
- Lists four basic heat treatments
- Explains the purpose of the four basic heat treatments
- Describes the following processes and the types of steel to which they might be applied:
 - annealing
 - normalizing
 - hardening
 - tempering
- Completes items of information in a table which gives the following details for the tempering of high-carbon steel:
 - temperatures (230 to 320 °C)
 - colour
 - application conditions
 - typical tool applications
- Explains how a component is tempered throughout its whole cross-section
- Carries out the heat treatments listed in the above objective
- Tests a hardened and tempered cutting edge, taking the necessary safety precautions

3.1.3 PROPERTIES AND PARAMETERS CONSIDERED IN THE FABRICATION AND REPAIR OF SYSTEMS AND COMPONENTS (19 hours)

Textbooks: T7, T13, T24, T41
Teaching aids: A 1, A3, V1

Required performance:

3.1.3.1 Materials Under Load (5 hours)

- Defines stress as the internal resistance per unit area of a material to an externally applied load
- Defines strain as the deformation produced in a material by an externally applied load

- Describes three types of loading as:
 - tensile
 - compressive
 - shear
- Illustrates with the aid of simple sketches, a material under each of the applied loadings given in the above objectives, using arrows to indicate load and stress and dotted lines to indicate deformation
- Explains how stress and strain can be calculated in terms of loading and material dimensions, for the cases in the above objectives
- Defines, for an elastic material subjected to a tensile load:
 - elastic limit
 - yield point
 - ultimate strength
 - breaking strength
- States that, within the elastic limit, Hooke's law will apply
- Defines Hooke's law as:
$$\frac{\text{stress}}{\text{strain}} = \alpha \text{ constant}$$
- Defines the constant contained in Hooke's law as the Modulus of Elasticity
- Applies the above objectives with simple numerical calculations
- Shows, on a sketched graph of load to a base of corresponding extension values, the behaviour of an elastic materials under tensile loading and indicates the condition points listed above
- States the significance in engineering practice of the four physical properties in the above objectives

3.1.3.2 Vibration (3 hours)

R1

- States that vibration is caused by the effect of a single force or a succession of forces applied suddenly to elastic materials
- States that the forces causing vibration in a ship usually result from an imbalance in the machinery
- Describes the main sources of ship vibration as:
 - machinery with reciprocating components (e.g. pistons etc.)
 - ship's propeller blades rotating through water of varying pressure and velocity
 - rotating machinery which has not been balanced (e.g. some crankshafts)
 - rotating machinery becoming unbalanced through damage, erosion, corrosion or deposits (e.g. dirt, scale, etc.)
 - unbalanced power in the cylinders of a diesel engine
 - worn bearings in rotating machinery
- States that a ship's structure and machinery are constructed largely of materials which are elastic
- States that vibrations are transmitted from one elastic material or component to another
- States that anti-vibration materials are sometimes placed between connecting parts in order to reduce vibration
- States that if a component is vibrating a reversing stress is present in the material
- States that in normal working conditions the stresses due to vibrations are well within limits allowed for in the design
- States that vibrations in a component may be from different sources, which can cause resonance and magnify the effect
- States that if vibrations become excessive the stresses induced can cause permanent damage
- States that excessive vibration should not be allowed to continue
- States that when varying the rotational speed of machinery, stages may be encountered where vibrations become excessive
- Explains that the condition described in the above objective is normally due to a

resonance of vibrations which occurs at what is known as 'critical speeds'

- States that excessive vibration within machinery is not always apparent
- States that critical speeds are predictable and should be clearly marked on controls and known to engineer officers
- States that machinery should not be allowed to operate either at or close to a critical speed
- States that critical speed ranges should be passed through as quickly as possible
- States that in addition to including stress, vibration may cause securing devices to work loose
- Explains how vibration may be reduced

3.1.3.3 Self-Secured Joints (1 hour)

R1

- Sketches the stages of making self-secured joints
- Makes self-secured joints

3.1.3.4 Permanent Joints (1 hour)

- Lists the different ways of making permanent joints

3.1.3.5 Bonding Plastics (1 hour)

R1

- Describes the principle of bending plastics
- States the range of softening temperature for plastics
- Explains the care and safeguards necessary when heating plastics

3.1.3.6 Adhesives and Bonding (3 hours)

Health and safety

- Explains the care necessary when using adhesives, to include:
 - skin protection
 - storage
 - fire
 - toxicity
- States the advantages and disadvantage of adhesive bonding
- Describes the basic principles of joining by using an adhesive
- Sketches the four joint configurations
- States the purpose of an activator when using an epoxy resin
- States the significance of pot file
- Explains the limitations on the service conditions of epoxy resins
- States that special epoxy resins are made to meet particular service conditions
- Lists the steps necessary when bonding together:
 - two metal components
 - friction material to steel
- Describes briefly metal-to-metal bonding and applications using:
 - liquid or paste
 - beads or dry film

Joining Plastics

- States the three methods of joining plastics
- States the need to use the correct adhesive for the plastic to be joined
- Selects and uses the correct adhesive for a variety of applications for a variety of strength tests included in the above objectives

3.1.3.7 Pipework (5 hours)

R1

- Determines minimum bend radius with regard to pipe diameter, thickness, material and process to be used
- Selects pipe filters/strainers in piping systems
- Observes safety precautions
- Bends pipes, using both cold and hot techniques
- Removes bulk filler and residue
- Checks for ovality, thinning and other defects
- Anneals, normalizes or stress-relieves as necessary

3.1.4 METHODS FOR CARRYING OUT SAFE EMERGENCY/TEMPORARY REPAIRS (5 hours)

R1

Textbooks: T24, T41

Teaching aids: A 1

Required performance:

- Explains what is meant by an emergency/temporary repair
- Explains the differences between an emergency/temporary repair and a permanent repair
- Explains what should be taken into account when carrying out emergency/temporary repair
- Explains how to carry out emergency/temporary repairs in accordance with situations and materials
- Explains what sort of materials can be used for emergency/temporary repairs of pipings
- Explains what sort of materials can be used for emergency/temporary repairs of valves
- Explains what sort of materials can be used for emergency/temporary repairs of coolers
- Explains what sort of materials can be used for emergency/temporary repairs of boiler smoke tubes
- Explains methods for emergency/temporary repairs of overboard/sea water suction valves in case of leaking.
- Explains how to replace overboard/sea water suction valves under the afloat condition

3.1.5 SAFETY MEASURES TO BE TAKEN TO ENSURE A SAFE WORKING ENVIRONMENT AND FOR USING HAND TOOLS, MACHINE TOOLS AND MEASURING INSTRUMENTS (5 hours)

R1

Textbooks: T41, T70

Teaching aids: A 1, A3, V2, V5

Required performance:

- States that a well-organized work shop must be most effective to ensure a safe working environment and for using hand tools, machine tools and measuring instruments
- States the importance that all the tools and measuring instrument should be kept in good order and shape to avoid accidents and to ensure safety of life
- States that proper use of tools enables successful completion of the tasks
- States the importance that a careful attitude is necessary when working on any tasks
- States that first-aid box, fire extinguishers, appropriate lighting and ventilation should be in the work shop
- Describes the necessary control over the power supply to a machine tool
- Describes the basic differences between 'stop' and 'start' buttons
- Describes the purpose and siting of 'emergency stop' buttons

- Describes the situations where the following should be worn
 - safety helmets
 - eye protection
 - protective footwear
 - skin protection
- States when hands and arms should be washed with soap and water
- Describes the care necessary for hands, including for any cuts or abrasions

3.1.6 USE OF HAND TOOLS, MACHINE TOOLS AND MEASURING INSTRUMENTS (125 hours)

R1

Textbooks: T7, T41

Teaching aids: A 1, A3, V1

Required performance:

R1
STCW Code
B-III/1 pa.1

3.1.6.1 Hand Tools (15 hours)

- Lists hand tools usually used for fabrication and repair on board ships, showing actual hand tools such as various types of spanners, wrenches, pliers, drivers, nippers, benders, cutters, hacksaws, vises, gear pullers, files, drills, reamers, hammers, tap and dies, brushes, anvil, swage block, punches, scrapers, chisels, scissors and chucks
- Explains and demonstrates how to use hand tools usually used for fabrication and repair
- Explains and demonstrates correct selections of specific hand tools in accordance with their purposes of use
- Among others, describes the following with regard to thread cutting:
 - the purpose of taper, second and plug taps
 - what governs the diameter of the hole to be drilled prior to tapping
 - the difference in use of a die nut and a stock and die
 - the different techniques used when cutting:
 - small-diameter threads
 - large-diameter and fine threads
 - internal threads in open-ended and blind holes and external threads on small-and large-diameter rod
- Explains and demonstrates safety precautions necessary when using specific hand tools
(Supervised Student Activity)
- Uses various hand tools to acquire the fundamental skills of using them with sample materials provided

3.1.6.2 Powered Hand Tools (5 hours)

R1
STCW Code
B-III/1 pa.1

- Lists powered hand tools usually used for fabrication and repairs
- on board ships, showing actual powered hand tools such as various types of electrical/air driven grinders, sanders, drills, impact wrenches, portable jig saw, hand shear and nibbler
- Explains and demonstrates how to use powered hand tools usually used for fabrication and repair
- Explains and demonstrates safety precautions necessary in general when using electric/air driven hand tools
- Explains and demonstrates specific difficulties and necessary precautions when using electric/air driven hand tools
(Supervised Student Activity)
- Uses various powered hand tools to acquire the fundamental skills of using them with sample materials provided

3.1.6.3 Machine Tools

1) Drilling machines (10 hours)

R1
STCW Code
B-III/1 pa.1

- Lists the uses of a drilling machine
 - Explains engineering terms used to describe geometrical surface and vice-versa
 - Explains briefly how drills are held in a machine
 - Explains how a workpiece is held in place, emphasizing dangerous practice and the particular problem when drilling thin plate
 - Describes the procedure for inserting and removing drills with parallel and with tapered shanks
 - Describes the care necessary to avoid accidents when using a drilling machine
- (Supervised Student Activity)**
- Uses drilling machines to acquire the fundamental skills of using them with sample materials provided

2) Grinding machine (5 hours)

- Explains the purpose of a grinding machine
 - Explains how to use a grinding machine
 - Demonstrates an awareness of the dangers which exist when using a grinding machine
 - Describes the procedure to ensure safety when using a grinding machine
- (Supervised Student Activity)**
- Uses grinding machine to acquire the fundamental skills of using it with sample materials provided

3) Centre Lathe (20 hours)

R1

- Explains the primary purpose of a centre lathe, its construction and Functions
- Explains the roles of each part, performing their functions of chucks, centres, face plates, material removal, thread cutting and taper turning
- On a given diagram or machine, identifies the main features of a modern lathe
- On a given diagram or machine, indicates the features and dimensions which govern the capacity of a lathe
- Demonstrates an awareness of the dangers which exist when using a lathe

Cutting tools

- Explains various cutting tools in terms of materials
- Explains various cutting tools in terms of figures
- Explains various cutting tools in terms of functions

(Supervised Student Activity)

- Uses a centre lathe to acquire the fundamental skills of using it with sample materials provided

4) Welding and Soldering

a) Principles of electric arc welding (5 hours)

R1
STCW Code
B-III/1 pa.1

- Explains the suitability of low-, medium-and high-carbon steels for welding
- Sketches the relative positions of the electrode and the base metal when metallic arc welding manually
- States that A.C. welding is more common than D.C. welding
- Sketches the components and circuit necessary in arc welding
- Describes how welding electrodes are classified
- Describes the purpose of the electrode covering
- Explains how electrodes should be stored
- Explains how damp electrodes can be detected
- States how damp electrodes can be dried

- Identifies the tools commonly used when welding
- Describes the principle of metal arc gas-shielded welding
- Describes the principle of tungsten inert-gas welding

b) Principles of gas welding (5 hours)

R1
STCW Code
B-III/1 pa.1

- Explains the basic principles of gas welding
- Describes the principle features of a low-pressure system
- Explains what is meant by a high-pressure system
- Lists the fuel-oxygen/air mixtures
- Describes the flame produced when using oxygen and acetylene
- Explains the effect on the flame of mixing different proportions of oxygen and acetylene
- Describes the dangers of handling acetylene gas and the methods used for its storage in cylinders
- Explains why the maximum discharge rate should not be exceeded
- Identifies the safety fittings for an acetylene gas cylinder
- Compares the need for control of gas pressure for:
 - welding
 - cutting
- States that a two-stage gas pressure regulator gives a more precise control than a single-stage regulator
- Identifies the safety features of gas pressure gauges
- States that high-pressure blowpipes are unsuitable for use in a low-pressure system
- Identifies the principle parts of a high-pressure blowpipe
- Explains the care necessary for:
 - blowpipe
 - hoses
- Explains the purpose of hose check valves and flashback arresters
- Describes the sequence to be followed if a flashback arrester is triggered
- Explains the basic purpose of a cylinder manifold system
- Names the gas, states its approximate pressure and describes the cylinder outlet thread, given the colours of cylinders likely to be encountered
- Sketches the relative positions of the base metal, the filler wire and the welding nozzle when using:
 - the leftward technique
 - the rightward technique
- Demonstrates the welding procedure for both techniques in the above objective
- Explains the limitations of leftward welding
- Explains the advantage of the rightward technique

c) Welded joints in low-carbon steel (20 hours)

R1
STCW Code
B-III/1 pa.1

- Describes a butt weld
- Explains why plate edges are prepared
- Sketches cross-sections:
 - of typical plate-edge preparations
 - indicating the features of a good weld
 - of a typical multi-run weld
- Describe a fillet weld
- Sketches cross-sections of fillet joints, showing:
 - throat length with concave and convex reinforcement
 - tee joint plate-edge preparations
 - corner joints
 - lap joint

(Supervised Student Activity)

- Makes welded butt and fillet joints, using manual electric arc and gas welding techniques

d) Common faults in welded joints (1 hour)

- Identifies the errors which can occur when lining up joints prior to welding
- Explains the cause of distortion
- Sketches a butt-welded and a fillet-welded joint, showing the effect of distortion

R1
STCW Code
B-III/1 pa.1

e) Thermal cutting (10 hours)

- States the applications of flame and plasma-arc cutting
- Explains the principle upon which oxygen is used to cut iron
- Describes the conditions necessary in order to cut when using an oxygen-fuel gas mixture
- Identifies the common engineering metals which can and cannot be cut using an oxygen-fuel gas mixture
- Lists the gases commonly used as fuels
- Identifies the controls on a gas cutting blowpipe and demonstrates their purpose
- Explains the factors which affect the quality of cutting
- States the basic principles of plasma-arc cutting

(Supervised Student Activity)

- Uses an oxygen-fuel gas cutting torch to cut straight lines and curves in mild steel plate up to 10 mm thick to crop mild steel sections

f) Inspection (5 hours)

R1

- Constructs a checklist for visual inspection during:
 - electric welding
 - gas welding
- Constructs a list of the points to check visually after welding is completed
- Explains the limitations of visual inspection
- Carries out the following destructive tests on welded joints:
 - bend
 - macroscopic
 - nick-break
- Carries out penetrant tests on welded joints
- Describes the principle of:
 - ultrasonic inspection
 - microscopic inspection
- Lists common weld defects and their causes

g) Soldering (10 hours)

R1

- Explains why brazing is used
- Describes the basic principles of soldering

Soft soldering

- Explains the limitations of soft-soldered joints and the reasons
- Explains how soft-soldered joints might be strengthened
- With the aid of a simple sketch, describe the uses of a soldering iron
- States the main hazards and precautions necessary when soldering
- Tin is a soldering iron and makes soft-soldered joints
- Describes the process of sweating joints
- Explains the need for a flux, its application and its removal
- Explains the differences between and the uses of the following fluxes:
 - passive

- active
- Explains the differences between (including the approximate melting temperatures) and the uses of:
 - plumber's solder
 - tinman's solder

Hard soldering

- State the reason for hard soldering
- Identifies the metals which can be joined by:
 - silver solder
 - brazing
 - bronze welding
- States the processes to be followed, stating the approximate melting point when:
 - silver solder
 - brazing
 - bronze welding

(Supervised Student Activity)

- Makes soft-and hard-soldering joints

h) Safety and health when welding

R1

- States the protective clothing to be worn when welding on a bench
- States the additional protection necessary when welding in more difficult situations
- States the measures necessary to protect other personnel when welding
- States the precautions related specifically to gas welding
- Explains the effect of radiation from welding on the eyes and skin
- Describes the dangers of fumes from welding and how this should be dealt with
- Explains the principles of the precautions to be taken when welding or when a similar heating process is to be performed in tanks which have contained combustibles
- States the precautions to be taken when working in confined spaces
- States the care and precautions necessary when handling and storing compressed gas cylinders, with particular reference to acetylene and oxygen

R1
STCW Code
B-III/1 pa.1

3.1.6.4 Measuring Instruments (10 hours)

- Lists measuring instruments usually used for fabrication and repair on board ships, showing measuring instruments such as various types of scales, callipers, protractors, square and straight edge, vernier callipers, depth gauges micrometers, dial indicators, thickness gauges, radius gauges and screw pitch gauges
 - Explains and demonstrates how to use measuring instruments including their accuracy
 - Explains and demonstrates correct selections of specific measuring instruments in accordance with their purposes of use
- #### **(Supervised Student Activity)**
- Uses various measuring instruments to acquire skills of using them with sample materials provided

3.1.7 USE OF VARIOUS TYPES OF SEALANTS AND PACKINGS (5 hours)

R1

Textbooks: T24, T50
Teaching aids: A 1

Required performance:

- Explains what is meant by sealant, gasket and packing
- Explains the differences between gasket and packing

- Explains how packings are used showing actual packings such as various types of O-rings, gland packings, mechanical seals, oil seals and labyrinth packings
- Explains how gaskets are used showing actual gaskets such as various types of non-metallic gaskets, non-ferrous metallic gaskets, metallic gaskets and semi-metallic gaskets
- explains how sealants are used showing actual sealants such as various types of sealants, liquid packings and seal tapes
- **(Supervised Student Activity)**
- Uses various sealants and packings to acquire skills of using them with sample materials provided

COMPETENCE 3.2	Maintenance and repair of shipboard Machinery and equipment	IMO Reference
----------------	----------------------------------------------------------------	---------------

TRAINING OUTCOMES:

Demonstrates a knowledge and understanding of:

STCW CODE
Table A-III/1

- 3.2.1 SAFETY MEASURES TO BE TAKEN FOR REPAIR AND MAINTENANCE INCLUDING THE SAFE ISOLATION OF SHIPBOARD MACHINERY AND EQUIPMENT REQUIRED BEFORE PERSONNEL ARE PERMITTED TO WORK ON SUCH MACHINERY OR EQUIPMENT**
- 3.2.2 APPROPRIATE BASIC MECHANICAL KNOWLEDGE AND SKILLS**
- 3.2.3 MAINTENANCE AND REPAIR SUCH AS DISMANTLING, ADJUSTMENT AND REASSEMBLING OF MACHINERY AND EQUIPMENT**
- 3.2.4 THE USE OF APPROPRIATE SPECIALIZED TOOLS AND MEASURING INSTRUMENTS**
- 3.2.5 DESIGN CHARACTERISTICS AND SELECTION OF MATERIALS IN CONSTRUCTION OF EQUIPMENT**
- 3.2.6 INTERPRETATION OF MACHINERY DRAWINGS AND HANDBOOKS MARINE ENGINEERING DRAWING AND DESIGN**
- 3.2.7 THE INTERPRETATION OF PIPING, HYDRAULIC AND PNEUMATIC DIAGRAMS**

COMPETENCE 3.2	Maintenance and repair of shipboard machinery and equipment	IMO Reference
----------------	-------------------------------------------------------------	---------------

3.2.1 SAFETY MEASURES TO BE TAKEN FOR REPAIR AND MAINTENANCE INCLUDING THE SAFE ISOLATION OF SHIPBOARD MACHINERY AND EQUIPMENT REQUIRED BEFORE PERSONNEL ARE PERMITTED TO WORK ON SUCH MACHINERY OR EQUIPMENT (5 hours)

Textbooks: T41, T70
Teaching aids: A 1, A3, V2, V5

Required performance:

3.2.1.1 ISM Code (1 hour)

R5

- Explains the outline of ISM Code (International Safety Management) including the background and process of establishment

3.2.1.2 SMS (2 hours)

- Explains briefly how a SMS (Safety Management System) should be established and what sorts of documents are included
- Lists documents, checklists and others for safety measures for fabrication and repair and explains their specific purposes

3.2.1.3 Safety Measures to be Taken (2 hours)

R1

- States that safety measures to be taken for repair and maintenance can be identified through proper risk assessment
- States that safety measures based on SMS should be applied to identified risks
- Explains that tool box talks prior to repair and maintenance are effective for taking necessary safety measures
- Explains that safety measures include use of protective equipment, preparation of proper lighting, antislipping measures, preparation of safety procedures, setting up a safety barrier, preparation of a safe working platform, mechanical/electrical isolation of machinery to be repaired/maintained, prior checks based on SMS
- Explains that particular safety measures in accordance with machinery feature may be necessary

3.2.2 APPROPRIATE BASIC MECHANICAL KNOWLEDGE AND SKILLS (5 hours) R1

Textbooks: T24, T50
Teaching aids: A 1

Required performance:

- States that knowledge concerned in operation mechanism and construction of machinery equipment depending on Function 1 has to be necessary to carry out maintenance and repair (Refer to function 1)
- States that details of the construction of intended machinery/equipment/components have to be confirmed with their drawings/instruction books before working on the tasks
- States that understanding/interpretation of drawings and instruction books is required to carry out maintenance and repair

3.2.3 MAINTENANCE AND REPAIR SUCH AS DISMANTLING, ADJUSTMENT AND REASSEMBLING OF MACHINERY AND EQUIPMENT (145 hours) R1

Textbooks: T41, T70

Teaching aids: A1, A2, A3, V2, V3, V4

Required performance:

3.2.3.1 Fastening

- Identifies types of threaded fastener
- States that bolts/nuts should be equally tightened in correct sequence when fastening plates/blocks with more than two bolts/nuts
- Explains why studs are used
(Supervised student activity)
- Fits studs and bolts and uses correct tightening procedures
- Removes studs (intact and broken) and split nuts
- Demonstrates how to protect finished surfaces

3.2.3.2 Centrifugal Pumps (Supervised student activity)

- Dismantles:
 - casing
 - impeller
 - wear rings
 - shaft
 - bearings
 - gland/seal
 - air pump
 - float chamber
- Examines and measures all parts for wear and deterioration
- Re-fits, checking, clearances
- Replaces and adjusts seals

3.2.3.3 Reciprocating Pumps (Supervised student activity)

- Dismantles:
 - cylinders
 - piston/buckets
 - rings
 - valves
 - joins
 - glands
 - relief valves
- Measures wear in cylinders, neck rings and rods; checks ring gaps
- Machines and/or grinds in valves and seats
- Removes gland packing
- Selects and fits new gland packing

3.2.3.4 Screw and Gear Pumps (Supervised Student Activity)

- Dismantles:
 - rotors and gears
 - seals
 - bearings
 - relief valve

- Examines for wear and deterioration
- Re-fits, checking end clearances and backlash
- Replaces and adjusts seals

3.2.3.5 Valves

(Supervised Student Activity)

The followings are applied to typical stop valves and safety/relief valves:

- Examines seats, valves, spindles, glands
- Machine valves and seats
- Beds in valves on seats, using grinding paste
- Removes old gland packing
- Selects correct gland packing
- Repacks glands
- Tests

3.2.3.6 Air Compressors

(Supervised Student Activity)

– Dismantles, examines and replaces or repairs as found necessary:

- suction and delivery valves and seats
- piston and rings
- glands/seals
- relief valves and bursting discs
- coolers and cooling passages
- lubricating oil system
- drains

3.2.3.7 Heat Exchangers

(Supervised Student Activity)

– Dismantles and examines:

- for leakage
- for corrosion
- for erosion
- for fouling

– Checks provision for tube expansion:

- descales
- replaces tubes
- plugs tubes
- secures tube tightness in tube plates
- checks means of reducing corrosion
- fills and tests

3.2.3.8 Diesel Engine

(Supervised Student Activity)

– Dismantles and inspects all parts for wear and deterioration, including:

- pistons
- rings
- liners
- bearings
- valves
- cooling passages
- crankshaft alignment
- lubrication system

– Refurbishes Diesel Engine Components

- cylinder heads
- exhaust valves
- air-start valves

- fuel injector
- relief valve
- fuel injection pump
- Reassembles
- Checks timing and ascertains freedom of movement
- Checks condition of lubrication oil
- Purges air from fuel system
- Test runs

3.2.3.9 Turbocharger (Supervised Student Activity)

- Dismantles:
 - air filter
 - air casing
 - inducer(if fitted)
 - impeller
 - volute
 - diffuser
 - gas inlet grid
 - nozzle ring
 - rotor
 - bearings
- Examines all parts for wear and deterioration, paying particular attention to:
 - erosion in the air side
 - erosion in the turbine nozzles and in the blades
 - corrosion of the gas casing
 - hard deposits
 - damage to balding
 - condition of bearings
 - condition of labyrinths
 - obstructions in the bleed and sealing passages
 - lubrication system
- Reassembles and checks clearances

3.2.3.10 Boiler

- Explains the need for cleaning the fire side of a boiler and how to do it
- Describes how to inspect the fire side of a boiler and repair/maintenance
- Explains the need of cleaning up the water side of a boiler and how to do it
- Describes how to inspect the water side of a boiler and the repair/maintenance
- Describes how to restore the boiler after **(Supervised Student Activity)**
- Thrust block
- Stern tube
- Shaft bearings
- Shaft sealing equipment

3.2.3.12 Refrigeration Maintenance (Supervised Student Activity)

- Compressors
- Evaporator
- Condenser
- Expansion valve
- Oil separator

3.2.3.13 Oils Fuels and Lubricating System Maintenance (Supervised Student Activity)

- Filters
- Purifiers
- Bearings
- Settling-tanks
- Tank contents gauges

3.2.3.14 Deck Machinery Maintenance (Supervised Student Activity)

- Lifeboat davits and gear
- Mooring winch
- Windlass
- Winch
- Crane

3.2.4 THE USE OF APPROPRIATE SPECIALIZED TOOLS AND MEASURING INSTRUMENTS (5 hours)

Textbooks: T7, T41

Teaching aids: A1

Required performance:

- States that some machinery/equipment are installed with specialized tools and measuring instruments for their repair and maintenance
- Explains what sort of specialized tools and measuring instruments are supplied
- Explains how to use specific specialized tools and measuring instruments showing for overhauling diesel engine and steam turbine
- Explains how to use wear down gauge for stern tube bearing

3.2.5 DESIGN CHARACTERISTICS AND SELECTION OF MATERIALS IN CONSTRUCTION OF EQUIPMENT (15 hours)

Textbooks: T13, T24, T50

Teaching aids: A1

Required performance:

3.2.5.1 Selection of Materials in Construction of Equipment (6 hours) R1

- Explains what materials are used for constructing major parts of the following equipment
 - diesel engines: crank shaft, cylinder liner and head, piston, exhaust valve, bearing
 - steam turbines: turbine casing, rotor, blade, nozzle, reduction gear,
 - gas turbine: turbine casing, rotor, compressor, gas generator
 - boilers: water tube, furnace, steam and water drum, superheater
 - shafting: propeller shaft, stern tube bearing, propeller
 - pumps: impeller, casing, shaft, casing ring, sleeve, gear, screw, piston/bucket ring
 - heat exchangers: heating tube, cooling tube, shell
 - compressors: piston ring, valve, cylinder block, cylinder liner
 - purifiers: spindle, gravity disc, bowl body
 - high pressure/temperature valve: body, valve, valve seat

3.2.5.2 Design Characteristics (6 hours) R1

- Explains design characteristics developed to improve performance in
 - highly skewed propeller

- construction of diesel engines
- construction of steam turbine
- construction of gas turbine
- construction of boiler

3.2.5.3 Design characteristics of Bearings (3 hours)

R1

Plain Bearings

- Explains the limitations of direct-lined bearings
- Describes solid and lined inserts
- Describes briefly:
 - thick-walled
 - medium-walled liners
 - thin-walled liners
 - wrapped bushes
- Lists the ideal properties of a lubrication oil for plain bearings
- Describes the reasons for using white metal, copper-lead alloys, lead bronzes, tin bronzes, gun metals and aluminium-based alloys for plain bearings

Ball and Roller Bearings

- Compares the load-carrying abilities of ball and roller bearings
- Compares the ability of ball and roller bearings to carry radial and axial loads
- States the type of bearing suitable for shafts subject to angular misalignment
- Describes how ball and roller bearings are lubricated
- States the proportion of available volume to be filled when using grease
- States the maximum height of lubricant in a stationary bearing when using oil

3.2.6 INTERPRETATION OF MACHINERY DRAWINGS AND HANDBOOKS MARINE ENGINEERING DRAWING AND DESIGN (38 hours)

Textbooks: T 46
Teaching aids: A 1

Required performance:

3.2.6.1 Types of Drawing (2 hours)

R1

- Explains the purpose of a general arrangement
- Explains the purpose of assembly drawings
- Explains the purpose of component drawings
- Explains the use of collective single-part drawings
- Explains the use of pictorial drawings
- Lists the standard/routine information and references commonly given on drawings

3.2.6.2 Linework (4 hours)

R1

- Relates examples of lines to applications and vice-versa
- Draws tangents as required in practice
- Demonstrates what is meant by:
 - first-angle projection
 - third-angle projectionand sketches the correct symbol for both cases
- Using given examples, completes first-and third-angle projections with:
 - missing lines
 - missing views
 - simple plotted curves
- Re-draws given simple components and provides sufficient dimensions for their manufacture

- Completes orthographic projections of solids
- Completes sectional views in orthographic projection
- Draws a third-angle projection with hidden detail
- Explains the use of auxiliary projection

3.2.6.3 Pictorial Projection (4 hours) R1

- Draws isometric projections of simple solids
- Draws oblique projections of simple solids

3.2.6.4 Development (4 hours) R1

- Draws the development of a 90° intersection of circular trucking
- Draws the development of a cone
- Draws the development of a square pyramid
- Draws the development of a square-to-round transition piece

3.2.6.5 Dimensioning (5 hours) R1

- Dimensions a simple component, applying all correct standards
- Explains the advantage of datum dimensioning

3.2.6.6 Geometrical Tolerancing (2 hours) R1

- Explains briefly what is meant by geometrical tolerancing
- Relates symbols for geometrical tolerancing to the intended characteristics
- Using given reference material, applies tolerancing data to engineering drawings, to include examples of:
 - straightness
 - flatness
 - roundness
 - cylindricity
 - concentricity
 - squareness
 - parallelism
 - angularity
 - position

3.2.6.7 Limits and Fits (2 hours) R1

- Explains the need for limits and fits
- Given various ways of indicating limits of size, explains their meaning
- Explains the meaning of:
 - tolerance
 - actual size
 - basic size
 - nominal size
- Explains hole basis fits
- Explains shaft basis fit
- Explains, using examples:
 - clearance fits
 - transition fits
 - interference fits
- Describes, using examples, the cumulative effect of tolerances
- Explains what is meant by selective assembly
- Lists the factors which influence the selection of tolerances

3.2.6.8 Engineering Drawing Practice (15 hours)

R1

- Makes engineering drawings employing the following:
 - sections in two parallel planes
 - revolved sections
 - thin sections
 - part sections
 - half sections
 - hidden detail
 - machinery symbols
 - surface finish
 - angular dimensions
 - arrow heads
 - auxiliary dimensions
 - centre lines
 - pitch-circle diameters
 - threads
 - thick chain-lines
 - enlarged views
 - hatching
 - leader lines
- Using reference material, applies abbreviations to drawings
- Applies conventional representation of the following features
 - external and internal threads
 - squares on shafts
 - serrated and splined shafts
 - holes on a linear and on a circular pitch
 - bearings
 - interrupted views
 - tension and compression springs

3.2.7 THE INTERPRETATION OF PIPING, HYDRAULIC AND PNEUMATIC DIAGRAMS (5 hours)

R1

Textbooks: T24, T46, T50

Teaching aids: A1

Required performance:

- States that piping diagrams indicate all the information necessary for ship's machinery fittings
- Explains that piping diagrams include design characteristics of the system and propulsion plant
- Explains how to interpret piping diagrams taking a major system as an example
- Explains major symbol marks used in piping diagrams
- Explains major symbol marks used in hydraulic and pneumatic diagrams
- Explains operation mechanism of the major devices used in the hydraulic and pneumatic systems and how they work

Officer in Charge of an Engineering Watch

Function 4:

**Controlling the Operation of the Ship and Care for
Persons on Board at the Operational Level**

**Officer in Charge of an Engineering Watch
Function 4: Controlling the Operation of the Ship and Care for Persons
on Board at the Operational Level**

INDEX

Part A4: Course Framework	143
Aims	
Objective	
Entry standards	
Course certificate	
Staff requirements	
Teaching facilities and equipment	
Teaching aids	
CDs&DVDs	
IMO references	
Textbooks	
Part B4: Course Outline and Guidance Notes	149
Timetable	
Lectures	
Course outline	
Guidance notes	
Part C4: Detailed Teaching Syllabus	161
Introduction	
Explanation of information contained in the syllabus tables	
4.1 Ensure compliance with pollution prevention requirements	
4.2 Maintain the seaworthiness of the ship	
4.3 Prevent, control and fight fires on board	
4.4 Operate life-saving appliances	
4.5 Apply medical first aid on board ship	
4.6 Monitor compliance with legislative requirements	
4.7 Application of leadership and teamworking skills	
Annex 1 Ship stability data	
Annex 2 Trim table	
Annex 3 Harmonized system of surveys	

Function 4 - Controlling the Operation of the Ship and Care for Persons on Board at the Operational Level

Part A4: Course Framework

Aims

This model course aims to meet the mandatory minimum requirements for knowledge, understanding and proficiency in TableA-III/1 of STCW 2010 for the function Controlling the Operation of the Ship and Care for Persons on Board at the Operational Level.

Objective

This syllabus covers the requirements of the The Manila Amendment of STCW Convention Chapter III, SectionA-III/1. This functional element provides the detailed knowledge to support the training outcomes related to Controlling the Operation of the Ship and Care for Persons on Board at the Operational Level.

This section provides the background knowledge to support:

- compliance with pollution-prevention requirements
- maintaining the seaworthiness of the ship, including:
 - ship stability
 - ship construction
- prevention, control and fighting of fires on board ship *
- operation of life-saving appliances *
- provision of medical first aid on board ship *
- monitoring compliance with legislative requirements
- Application of Leadership and Team-working skills
- Contribute to safety of personnel and ship

* These topics are covered in separate IMO model courses.

This function includes topics such as ship stability, carriage of cargoes on deck, heavy lifts, a containers, bulk cargoes, grain, dangerous goods, oil tankers and the IMO conventions.

Entry standards

This course is principally intended for candidates for certification as officer in charge of a engineering watch. Those wishing to enter this course should be following an approved programme of shipboard training. Alternatively, trainees may complete approved seagoing service of not less than three years/or as approved by the administration.

Course certificate

On successful completion of the course and assessments, a document may be issued certifying that the holder has successfully completed a course of training which meets or exceeds the level of knowledge and competence specified in Table A-III/1 of STCW The Manila Amendment, for the function Controlling the Operation of the Ship and Care for Persons on Board at the Operational Level.

A certificate may be issued only by centres approved by the Administration.

Staff requirements

Instructors shall be qualified in the task for which training is being conducted and have appropriate training in instructional techniques and training methods (STCW Code Section A-I/6). Depending on the complexity of the exercises set, an assistant instructor with similar experience is desirable for certain practical exercises.

Teaching facilities and equipment

A classroom equipped with an overhead projector and a blackboard, whiteboard or flipchart should be provided for teaching the theory of the course and holding group discussions.

The following equipment is recommended:

- cut-away three-dimensional models showing the structure of parts of the ship
- photographs, drawings and plans illustrating various types of ship and constructional details
- a floating ship stability demonstration model and a flotation tank. The model should be capable of demonstrating the effects of adding or removing masses, shifting masses, suspending masses and free liquid surface.
- a marine hydrometer

Teaching aids (A)

A1 Instructor Guidance (Part B of this course)

A2 DVD Player

CDs and DVDs

D1 DVD: IMO – Safe, Secure and Efficient Shipping on Clean Oceans (2006 Edition)
IMO Sales No. V010M ISBN 978-92-801-70023

Available from: IMO Publications Section
4 Albert Embankment
London SE1 7SR, UK
Fax: +44 20 7587 3241
URL: www.imo.org

- D2 SEVEN STEPS TO SHIP STABILITY PART 1 Code No: 622
SEVEN STEPS TO SHIP STABILITY PART 2 Code No: 623
- D3 ENTERING INTO ENCLOSED SPACES (EDITION 2) Code No: 682
- D4 DEATH IN MINUTES - RESCUE TECHNIQUES FROM CONFINED SPACES Code
No: 750
- D5 PERMIT TO WORK Code No: 621
- D6 SAFE HOT WORK PROCEDURES Code No: 701
- D7 WASTE AND GARBAGE MANAGEMENT Code No: 627
- D8 FIGHTING POLLUTION - PREVENTING POLLUTION AT SEA (EDITION 3)
Code No: 755
- D9 HULL STRESS MONITORING, Code No: 550
- D10 SHIPPING CASUALTY EMERGENCY RESPONSE, Code No: 467
- D11 SURVIVAL, Code No: 681
- D11 BASIC FIRE FIGHTING (EDITION 3), Code No: 674
- D12 HELICOPTER OPERATIONS AT SEA (EDITION 2), Code No: 704
- D13 STCW AND FLAG STATE IMPLEMENTATION, Code No: 629
- D14 SEARCH TECHNIQUES, Code No: 935
- D15 SECURITY AT SEA, Code No: 484
- D16 IMMERSION SUITS - THE DIFFERENCE BETWEEN LIFE AND DEATH,
Code No: 947
- D17 MUSTER LISTS, DRILLS & HELICOPTER OPERATIONS, Code No: 678
- D18 MLC 2006, Code No: 986
- D19 SHIPSHAPE. A GUIDE TO GOOD HOUSEKEEPING PART 1: ON DECK,
Code No: 974

- D20 THE SHIPBOARD MANAGEMENT ROLE (EDITION 2), Code No: 969
- D21 PORT STATE CONTROL - TIGHTENING THE NET (Edition 2), Code No: 977
- D22 HEALTH & WELFARE ADVICE FOR SEAFARERS, Code No: 510
- D23 PERSONAL HYGIENE, Code No: 993
- D24 MEDICAL FIRST AID (Edition 2), Code No: 990
- D25 ENCLOSED LIFEBOATS, FREEFALL LIFEBOATS RESCUE BOATS,
Code No: 679
- D26 LOAD LINE SURVEYS - PART 1, Code No: 544
- D27 SAFETY CONSTRUCTION SURVEY - PART 2, Code No: 545
- D28 SAFETY EQUIPMENT SURVEY - PART 3, Code No: 546

Available from: Videotel Marine International Ltd.,
84 Newman Street, London W1 P 3LD, UK
Tel: +44 20 72991800 Fax: +442072991818
e-mail: mail@videotelmail.com
URL: www.videotel.co.uk

IMO references (R)

- R1 International Convention on Standards of Training, Certification and Watchkeeping for Seafarers (STCW), 1998 (with amendments (1 & 4), 2001 Edition. IMO Sales No. IB938E ISBN 978-92-801-51084
- R2 International Convention for the Safety of Life At Sea, SOLAS (Consolidated Edition, 2009). IMO Sales No. IE110E ISBN 978-92-801-15055
- R3 International Convention on Load Lines, 1966 2005 Edition IMO Sales No. IB701E ISBN 978-92-801-41948
- R4 International Convention for the Prevention of Pollution from Ships. 1973 / 78. (MARPOL) Consolidated Edition, 2006 IMO Sales No. IC520E ISBN 978-92-801-42167
- R5 MARPOL – How to do it, 2002 Edition. IMO Sales No. IA636E ISBN 978-92-801-41528
- R6 Pollution prevention equipment under MARPOL, 2006 Edition. IMO Sales No. IA646E ISBN 978-92-801-14706
- R7 Manual on Oil Pollution - Section II – Contingency Planning, 1995 Edition
IMO Sales No. IA560E ISBN 978-92-801-13303

Manual on Oil Pollution - Section III - Salvage, 1997 Edition
IMO Sales No. IA566E ISBN 978-92-801-14423

Manual on Oil Pollution - Section IV – Combating Oil spills, 2005 Edition
IMO Sales No. IA569E ISBN 978-92-801-41771

Manual on Oil Pollution - Section V: Administrative Aspects of Oil Pollution Response, 2009 Edition
IMO Sales No. IA572E ISBN 978-92-801-15000

Manual on Oil Pollution - Section VI - IMO Guidelines for Sampling and Identification of Oil Spills, 1998 Edition
IMO Sales No. I578E ISBN 978-92-801-14515
MANUAL ON CHEMICAL POLLUTION - Section 1 – Problem Assessment and Response Arrangements (1999 Edition)

- IMO Sales No. IA630E ISBN 978-92-801-60963
MANUAL ON CHEMICAL POLLUTION - Section 2 – Search and Recovery of
Packaged Goods Lost at Sea (2007 Edition)
IMO Sales No. IA633E ISBN 978-92-801-42228
- R8 United Nations Conference on the Law of the Sea, Official Records Volume II Plenary
Meetings.
Geneva, 1958 (United Nations Publication Sales No. 58.VA, Vol II)
containing:
Geneva Convention of the Territorial Sea and the Contiguous Zone, 1958
Geneva Convention on the High Seas, 1958
Geneva Convention on the Continental Shelf, 1958
- R9 United Nations Convention on the Law of the Sea. New York, 1983 (United Nations
Publication Sales No. E.83.V.5)
- R10 IMO Assembly Resolution A.671 (16) - Safety Zones and Safety of Navigation Around
Offshore Installations and Structures
- R11 Supplement relating to the International Convention on Load Lines, 1966
(IMO Sales No. 705)
- R13 IMO Assembly Resolution A.760(18) 1993. Symbols related to life-saving appliances
and arrangements
- R14 IMO Assembly Resolution A.921(22) 2001. Assembly resolutions superseded
by the 1995 amendments to the 1978 STCW Convention
- R15 International Maritime Dangerous Goods Code (IMDG Code), 2008 Edition
(incorporating amendment 34-08) IMO Sales No. IG200E ISBN 978-92-801-42419
- R16 International Maritime Solid Bulk Cargoes Code (IMSBC Code) and Supplement
(2009 Edition) IMO Sales No. IE260E ISBN 978-92-801-42396
- R17 International Code for the Construction and Equipment of Ships Carrying Dangerous
Chemicals in Bulk (IBC Code) (2007 Edition)
IMO Sales No. IC100E ISBN 978-92-801-42266
- R18 INTERNATIONAL CODE FOR THE CONSTRUCTION AND EQUIPMENT OF SHIPS
CARRYING LIQUEFIED GASES IN BULK (IGC Code) (1993 Edition)
IMO Sales No. I104E ISBN 978-92-801-12771
- R19 INTERNATIONAL CONFERENCE ON SPECIAL TRADE PASSENGER SHIPS, 1971
(1972 Edition) IMO Sales No. I727B ISBN 978-92-801-00136
- R20 WHO International Health Regulations (1969), 3rd annotated ed. (Geneva, World
Health Organization, 1983), (HR), (ISBN 92-4-158007-0)
- R21 INTERNATIONAL CONFERENCE ON SPACE REQUIREMENTS FOR SPECIAL
TRADE PASSENGER SHIPS, 1973 (1973 Edition)
IMO Sales No. I734B ISBN 978-92-801-00228
- R22 ATHENS CONVENTION RELATING TO THE CARRIAGE OF PASSENGERS AND
THEIR LUGGAGE BY SEA, 1974 (PAL 1974) (2003 Edition)
IMO Sales No. IA436E ISBN 978-92-801-41610
- R23 INTERNATIONAL CONFERENCE ON TONNAGE MEASUREMENT OF SHIPS,
1969 (1970 Edition)
IMO Sales No. I713E ISBN 978-92-801-10906
- R24 IMO Assembly Resolution A.494 (XII) - Revised Interim Scheme for Tonnage
Measurement for Certain Ships
- R25 IMO Assembly Resolution A.540 (13) - Tonnage Measurement for Certain Ships
Relevant to the International Convention on Standards of Training, Certification And
Watchkeeping for Seafarers, 1978
- R26 IMO Assembly Resolution A.541 (13) - Interim Scheme for Tonnage Measurement

- for/Certain Ships for the Purpose of the International Convention for the Prevention of Pollution From Ships, 1973, As Modified by the Protocol of 1978 Relating Thereto
- R27 IMO Assembly Resolution A.769(18) - Procedures and Arrangements for Issuing GMDSS Certificates to Holders of Non-GMDSS Certificates
- R28 IMO/ILO Document for Guidance, 1985, (IMO Sales No. 935)
- R29 INTERNATIONAL SAFETY MANAGEMENT CODE (ISM Code) AND GUIDELINES ON IMPLEMENTATION OF THE ISM CODE (2010 Edition)
IMO Sales No. IB117E ISBN 978-92-801-51510
- R30 International Life Saving Appliance Code (LSA Code) (2010 edition)
IMO Sales No. ID982E ISBN 978-92-801-15079
- R31 International Code for Fire Safety Systems (FSS Code)
IMO Sales No. IA155E ISBN 978-92-801-14812
- R32 INTERNATIONAL CODE FOR APPLICATION OF FIRE TEST PROCEDURES (FTP Code)(1998 Edition)IMO Sales No. IB844E ISBN 978-92-801-14522
- R33 GRAPHICAL SYMBOLS FOR FIRE CONTROL PLANS (2006 Edition)
IMO Sales No. IA847E ISBN 978-92-801-42259
- R34 INTERNATIONAL CODE ON INTACT STABILITY, 2008 (2009 Edition)
IMO Sales No. IB874E ISBN 978-92-801-15062
- R35 PREVENTION OF CORROSION ON BOARD SHIPS (2010 Edition)
IMO Sales No. I877M ISBN 978-92-801-00358
- R36 IMO Assembly Resolution A.1001(25) 2007. Criteria for the provision of mobile satellite communication systems in the global maritime distress and safety system (GMDSS)
- R37 IMO Assembly Resolution A.705(17) 2008. Amendments to Resolution A.705(17) – Promulgation of Maritime Safety Information
- R38 IMO Assembly Resolution A.706(17) 2008. Amendments to Resolution A.706(17) – World-Wide Navigational Warning Service
- R39 MSC.306(87) 2010. Revised performance standards for enhanced group call (EGC) equipment
- R40 IMO/UNEP GUIDELINES ON OIL SPILL DISPERSANT APPLICATION INCLUDING ENVIRONMENTAL CONSIDERATIONS (1995 Edition)
IMO Sales No. IA575E ISBN 978-92-801-13327
- R41 MANUAL ON OIL SPILL RISK EVALUATION AND ASSESSMENT OF RESPONSE PREPAREDNESS (2010 Edition)
IMO Sales No. I579E ISBN 978-92-801-15123
- R42 GUIDELINES FOR THE DEVELOPMENT OF SHIPBOARD MARINE POLLUTION EMERGENCY PLANS (2010 Edition)
IMO Sales No. IB586E ISBN 978-92-801-15185
- R43 PROCEDURES FOR PORT STATE CONTROL (2000 Edition)
IMO Sales No. IA650E ISBN 978-92-801-50995
- R44 INTERNATIONAL CONVENTION ON THE CONTROL OF HARMFUL ANTI-FOULING SYSTEMS (AFS) ON SHIPS, 2001 (2005 Edition) IMO Sales No. IA680E ISBN 978-92-801-41955

Details of distributors of IMO publications that maintain a permanent stock of all IMO publications may be found on the IMO web site at <http://www.imo.org>

Textbooks (T)

- T11 Bryan Barrass & Capt D R Derrett, *Ship Stability for Masters and Mates*, 6th ed. Butterworth Heinemann, 2006 (ISBN-13:978-0-7506-6784-5, ISBN-10:0-7506-6784-2)
- T19 Hill, C. *Maritime Law*, 6th ed. London, Lloyd's of London Press, 2003 (ISBN 1-84311-255-8)
- T31 ICF, OCIMF & IAPH, *International Safety Guide for Oil Tankers and Terminals (ISGOTT)*. 5th ed. London, Witherby & Co. Ltd., 2006 (ISBN 1-85609-291-7)
- T58 Taylor, D.A. (Dr.) *Merchant Ship Construction*, 4th ed. London, Institute of Marine Engineers, 1998 (ISBN 0-408-01535-7)
- T66 Capt P. Roberts, *Watchkeeping Safety and Cargo Management in Port*. London, The Nautical Institute, 1995 (ISBN-10: 1-870077-29-6)
- T70 Maritime and Coastguard Agency (MCA), *Code of Safe Working Practices for Merchant Seamen*, London. The Stationery Office Publications Centre, Consolidated Edition, 2009 (ISBN 9780115530784)

Function 4: Controlling the Operation of the Ship and Care for Persons on Board at the Operational Level

Part B4: Course Outline and Guidance Notes

Timetable

No formal example of a timetable is included in this model, course.

Development of a detailed timetable depends on the level of skills of the trainees entering the course and the amount of revision work of basic principles that may be required.

Lecturers must develop their own timetable depending on:

- the level of skills of trainees
- the numbers to be trained
- the number of instructors

and normal practices at the training establishment.

Preparation and planning constitute an important factor which makes a major contribution to the effective presentation of any course of instruction.

Lectures

As far as possible, lectures should be presented within a familiar context and should make use of practical examples. They should be well illustrated with diagrams, photographs and charts where appropriate, and be related to matter learned during seagoing time.

An effective manner of presentation is to develop a technique of giving information and then reinforcing it. For example, first tell the trainees briefly what you are going to present to them; then cover the topic in detail; and, finally, summarize what you have told them. The use of an overhead projector and the distribution of copies of the transparencies as trainees handouts contribute to the learning process.

Course outline

The tables that follow list the competencies and areas of knowledge, understanding and proficiency, together with the estimated total hours required for lectures and practical exercises. Teaching staff should note that timings are suggestions only and should be adapted to suit individual groups of trainees depending on their experience, ability, equipment and staff available for training.

COURSE OUTLINE

Knowledge, understanding and proficiency	Total hours for each topic	Total hours for each subject area of Required performance
------------------------------------------	-------------------------------	-----------------------------------------------------------------

Competence:

4.1 ENSURE COMPLIANCE WITH POLLUTION-PREVENTION REQUIREMENTS

4.1.1 THE PRECAUTIONS TO BE TAKEN TO PREVENT POLLUTION OF THE MARINE ENVIRONMENT

.1 MARPOL 73/78	7	7
-----------------	---	---

4.1.2 ANTI POLLUTION PROCEDURES AND ASSOCIATED EQUIPMENT

.1 Regulation 26 - Annex 1 MARPOL 73/78	2	
.2 Anti-Pollution Equipment	1	3

4.1.3 IMPORTANCE OF PROACTIVE MEASURES 2 2

4.2 MAINTAIN THE SEAWORTHINESS OF THE SHIP

4.2.1 SHIP STABILITY

.1 Displacement	4	
.2 Buoyancy	2	
.3 Fresh water allowance	3	
.4 Statical stability	3	
.5 Initial stability	4	
.6 Angle of loll	1	
.7 Curves of statical stability	4	
.8 Movement of centre of gravity	4	
.9 List and Its Correction	6	
.10 Effect of slack tanks	3	
.11 Trim	6	
.12 Loss of intact buoyancy1	41	

4.2.2 SHIP CONSTRUCTION

.1 Ship dimensions and form	12	
.2 Ship Stresses	8	
.3 Hull structure	11	
.4 Bow and stern	6	
.5 Fittings	10	
.6 Rudders and propellers	11	
.7 Load lines and draught marks	5	63

4.3 PREVENT, CONTROL AND FIGHT FIRES ON BOARD

See IMO Model Course No 2.03 and STCW 2010 regulation VI/3

4.4 OPERATE LIFE-SAVING APPLIANCES

See IMO Model Course No 1.23, and STCW 2010 regulation VI/2 paragraph 1-2

4.5 APPLY MEDICAL FIRST AID ON BOARD SHIP

See IMO Model Course No 1.14, and STCW 2010 regulation VI/4 paragraph 1-3

4.6 MONITOR COMPLIANCE WITH LEGISLATIVE REQUIREMENTS

4.6.1 BASIC WORKING KNOWLEDGE OF THE RELEVANT IMO CONVENTIONS CONCERNING SAFETY OF LIFE AT SEA AND PROTECTION OF THE MARINE ENVIRONMENT

International Convention on Load Lines, 1966	3	
SOLAS, 1974 as amended	2	
SOLAS—Subdivision and stability	2	
SOLAS—Fire protection, detection and extinction	2	
SOLAS—LSA and arrangements (LSA Code)	2	
SOLAS—radiotelegraphy and R/T	2	
SOLAS—Radiocommunications (amended Chap. 1V)	2	
SOLAS—Carriage of grain	1	
SOLAS—Carriage of dangerous goods	1	
STCW, 1995	2	
ITU Radio regulations	2	
STP ships Agreement, 1971	1	
SPACE STP, 1973	1	
PAL, 1974 and Tonnage 1969	1	
BWM 2004	1	25

4.7 APPLICATION OF LEADERSHIP AND TEAMWORKING SKILLS

.1 Introduction to Management	2	
.2 Related Conventions and National Legislations	2	
.3 Applies Task and Workload Management	10	
.4 Applies Effective Resource Management and Decision Making	10	24

4.8 CONTRIBUTE TO THE SAFETY OF PERSONNEL AND SHIP

See *IMO Model Course No 1.13, 1.19, 1.20, 1.21, and STCW 2010 regulation VI/1 and Section A-VI/1 paragraph 2*

Total for Function 4: Controlling the Operation of the Ship and Care for Persons on Board at the Operational Level 165 hours

Guidance Notes

The following notes are intended to highlight the main objectives or training outcomes of each part of the function. The notes also contain some material on topics which are not adequately covered in the quoted references.

Trainees will be aware of the need and the practical measures required by law to prevent pollution of the environment. They will understand the requirements of MARPOL 73/78, (R4) the technical annexes, control of oil from machinery spaces and the Oil Record Book (Part1), (R5, V7)

Function 4: Controlling the Operation of the Ship and Care for Persons on Board at the Operational Level

On completion of training for this function trainees will be able to use plans and tables or diagrams of stability and trim data to calculate the ship's initial stability, draughts and trim for any given disposition of cargo and other weights. They will also be able to determine whether stresses on the ship are within permitted limits by the use of stress data, calculating equipment or software. The fundamental actions to take in the event of partial loss of intact buoyancy will be understood.

They will have knowledge of the principal structural members of a ship and the proper names of the various parts.

Training concerned with Advanced Training in Fire-fighting is covered in IMO model course 2.03.

Training concerned with proficiency in survival craft and rescue boats other than fast rescue boats is covered in IMO model course 1.23.

Training concerned with proficiency in medical first aid on board ship is covered in IMO model courses 1.14.

4.1 Ensure Compliance with Pollution—Prevention Requirements

4.1.1 The Precautions to be Taken to Prevent Pollution of the Marine Environment

Prevention of Pollution

In implementing this section of the course, the instructor should bear in mind that any officer of the watch aboard tankers will have completed a tanker familiarization course which should include the relevant requirements on pollution prevention related to tanker operations. This section is intended to provide an outline knowledge of the MARPOL Convention. In the following sections, detailed treatment should be confined to those requirements of the Convention which apply to all ships (V1, V2)

MARPOL technical annexes

The annexes set out the rules for the construction and equipment of ships and for ships' operations which may result in marine pollution.

4.1.2 Anti Pollution Procedures and Associated Equipment

Annex I

Oil is defined in Annex I as any mineral oil and includes petrochemical products other than those listed in Annex II

Compliance with construction and equipment requirements is enforced through the International Oil Pollution Prevention (IOPP) Certificate and regular surveys to ensure that

the ship continues to comply with the requirements of the certificate. Port States verify that a ship has a certificate and may, if necessary, carry out a survey and demand rectification of deficiencies. The Port State also inspects the Oil Record Book to check that the ship is adhering to the required operating procedures. Coastal States may enforce Annex I by regular air patrols which keep a watch for oil slicks.

Control of oil from machinery spaces

Waste oil is generated in lubricating oil and fuel oil purifiers. Under Annex I, discharge of this sludge into the sea is not permitted.

Oil and water leakages in machinery spaces give rise to oil and water mixtures in bilges which have to be disposed of from time to time to prevent them becoming a fire or stability hazard. Many ships have bilge-water holding tanks to enable bilges to be kept clean and dry in port. The contents of the tank can then be discharged at sea, using a separator. The separated oil is dealt with in the same way as other waste oil. The need to retain this on board until arrangements can be made for disposal requires the provision of a tank for oil residues. Annex I makes provision for this.

The equipment required for machinery spaces is set out in the regulations. The discharge provisions are similarly governed.

Oil Record Book (Part I, Machinery Space Operations)

The requirements for keeping records and the form of the Oil Record Book are set out in the relevant regulations (V7).

Precautions which should be taken to prevent accidental pollution by oil

Officers who are to serve in oil, chemical or gas tankers will undertake specialized courses which include pollution-prevention precautions applicable to those specialized ships. The precautions in this section apply to bunkering and the discharge of oily wastes, which are operations common to all ships, and are similar to those to be taken when loading or discharging an oil cargo (V6).

Sewage

Under Annex IV ships are not permitted to discharge sewage within four miles of the nearest land, unless they have in operation an approved treatment plant. Between 4 and 12 miles from land, sewage must be comminuted and disinfected before discharge.

4.1.3 Importance of Proactive Measures

Importance of proactive measures to protect the marine environment encourages engineer officers to observe regulations concerned in the actual tasks on board ships which give direct impacts on the marine environment. Trainees therefore, need to learn about that careful treatment of pollution substances is strictly required.

4.2 Maintain the Seaworthiness of the Ship

4.2.1 Stability, Trim and Stress Tables

A ship's hydrostatic information is given for the even keel condition, so the true mean draught should be used to enter the tables or graphs. Since a ship is rarely on an even keel when draughts are read, either a calculation to correct the arithmetical mean draught must be made or the arithmetical mean draught may be used as an approximation.

Unless trim angles are excessive, the errors resulting from using arithmetical mean draught are small. In cases where complex accuracy is essential, draught surveys for example, the calculations would not be left to the officer of the watch. For the purposes of this course the arithmetical mean draught may be used when working with hydrostatic curves or tables. Data suitable for the preparation of exercises are contained in the Annex to these guidance notes. See also ref V3.

Displacement

Archimedes' law and the principles of flotation should have been covered in physical science before starting this subject.

Buoyancy

Buoyancy in general should have been covered in physical science. The concept of reserve buoyancy and its importance to the safety of the ship should be emphasized.

Fresh water allowance

This should be developed by considering the relationship between buoyancy and water density. Calculations on box-shaped vessels can be used to show how the TPC for fresh water or dock water is related to the tabulated value for seawater.

Statically stability

This section introduces the lever GZ as the horizontal separation between the equal and opposite forces through G and B. The tendency for a stable ship to return to the upright is shown to depend upon the resulting couple.

Initial stability

The transverse metacentre is introduced and the way in which GZ is related to the metacentric height for small angles of heel is derived. A comparison of the behaviour of stiff and tender ships in a seaway is included. A floating model can be used to demonstrate the effect on rolling period.

Angle of loll

The fact that an initial capsizing moment results if G is above M is to be shown. It may be possible to show an angle of loll by using a floating model although it is difficult to avoid large angles of list, due to slight displacement of the model's centre of gravity, confusing the experiment. Even so, the experiment demonstrates the unsatisfactory condition of a ship with a GM of nearly zero.

Curves of statical stability

Trainees should construct some curves of statical stability, using KN curves and given values of KG, including a curve for a ship with a negative GM.

Movement of the centre of gravity

Trainees should be able to deduce that adding masses above, or removing masses below, the original centre of gravity causes an increase in KG. Both processes can occur during a passage as water is absorbed by deck cargo and fuel is consumed from double-bottom tanks.

When dealing with the point of suspension, point out that lowering or raising the weight has no effect on the ship's centre of gravity. Only movement of the point of suspension, where the weight is acting, has any effect on KG.

List and its correction

Trainees should be reminded that the equation for angle of list applies only for small angles of list, up to about 10°, for which the position of M can be taken as fixed.

Effect of slack tanks

It should be pointed out that any free liquid surface, such as water trapped on the weather deck or water used for fire fighting, will cause a similar increase in the value of KG.

Trim

The calculation of trim and final draughts after large changes in deadweight is not included. The lecturer should explain why trim tables should not be used for large changes in deadweight. The theory behind a vessel's change in trim due to a change in water density may also be covered.

In tankers and bulk carriers, the quantity and disposition of cargo is often similar to that of a previous loading. When planning the loading of such a cargo, the final draughts and trim can be obtained by making the necessary small adjustments to the actual draughts recorded for the previous cargo.

Actions to be taken in the event of a partial loss of intact buoyancy

The immediate actions which should be taken by the officer in charge of the watch are aimed at limiting the volume of lost buoyancy to the minimum. At the same time, if cross-flooding arrangements are required, they should be put into operation immediately to restrict the angle of list. Whether anything can be done to stop or reduce the inflow of water will depend upon the circumstances. In the event of loss of buoyancy due to damage to a hatch cover, a prompt reduction in speed or alteration of course, or both, may be effective.

4.2.2 Ship Construction

The trainees should have knowledge of the principal structural members of a ship and the proper names of the various parts. Their knowledge should be such that they are capable of intelligent observation during the ordinary course of their work and can make adequate reports describing the location and nature of faults or minor damage discovered.

Ship dimensions and form

Particulars of constructional details of the various ship types are not intended. A knowledge of the general arrangement of various ship types is also applicable to other areas, such as cargo work and pollution prevention

Ship stresses

A mathematical treatment of shear force and bending moments is not required at this stage. A qualitative description to explain the forces which the ship must be designed to withstand and the parts mainly involved in resisting them is needed.

When dealing with liquid pressure in tanks, attention should be drawn to the high forces on tank tops resulting from filling tanks until there is a head of liquid in air pipes and sounding pipes.

Hull structure

This section deals with the main structure of the hull, the names of the principal parts and how they are connected. Models and three-dimensional drawings are valuable aids to understanding the various connections and stiffening arrangements shown on the usual plan and elevation drawings.

Bow and stern

Details of construction have been limited to the transom stern since that is the commonest construction at present.

Fittings

The closing of hatches with wooden covers and tarpaulins has been included because there are still a number of older ships with that arrangement or a similar one using pontoon covers.

When dealing with bilge or ballast piping systems, show how the nonreturn valves are placed to prevent flooding of adjacent spaces through fractured pipelines. When dry cargo is carried in deep tanks, the ballast lines have blanks fitted to prevent accidental filling of the tanks. A similar arrangement is provided in cargo holds which are connected to the ballast system.

Rudders and propellers

Knowledge of the method of operation of controllable-pitch propellers is not required. Trainees should be aware that the amount and direction of thrust are controlled by altering the pitch of the propeller. They should also realize that when going astern a controllable-pitch propeller acts as an opposite-handed propeller to when going ahead. Many controllable-pitch propellers are made left-handed going ahead so that they behave in the same way as the usual right-handed propellers when acting astern.

Load lines and draught marks

It is not intended that trainees should know how the summer freeboard is assigned. They should know that it is the minimum freeboard permitted when loading in seawater in a summer zone and that it is assigned to the ship by, or on behalf of, the Administration in accordance with the Load Line Regulations. They should also know that the load line mark is placed at that distance below the deck line.

It should be impressed upon trainees that, when loading to the minimum permitted freeboard, checks should be made of the actual freeboard amidships on each side. Even a barely perceptible list can produce a difference of several centimetres in the readings from opposite sides.

4.3 Prevent, Control and Fight Fires on Board

The requirements of the STCW Convention are covered by IMO model course, Basic Fire Fighting. That course is based on the recommendations set out in IMO Assembly resolution and the IMO/ILO Document for Guidance (R28).

Trainees should undertake this course as soon as possible in their career, preferably during the pre-sea stage at a shore-based establishment.

IMO Assembly resolution states "Masters, officers and as far as practicable key personnel who may wish to control fire-fighting operations should have advanced training in techniques for fighting fire with particular emphasis on organization, tactics and command".

IMO model course, Advanced Training in Fire Fighting is suitable for this purpose and Administrations may wish this course to be completed before trainees qualify as officer in charge of a watch. See also IMO Model Course No 2.03.

4.4 Operate Life-Saving Appliances

The requirements of the STCW Convention are fully covered by IMO model course 1.23, Proficiency in Survival Craft and Rescue Boats other than Fast Rescue Boats, which is based on the requirements of the STCW Convention. Trainees who have successfully completed that course and have been issued with a certificate of proficiency in survival craft have demonstrated the ability and knowledge necessary to satisfy the requirements of the regulations.

4.5 Apply Medical First Aid on Board Ship

The requirements of the STCW Convention are covered by IMO model courses 1.14.

4.6 Monitor Compliance with Legislative Requirements

4.6.1 Basic Working Knowledge of the Relevant IMO Conventions Concerning Safety of Life at Sea and Protection of the Marine Environment

The extent and depth of knowledge required of the IMO Conventions and implementation by flag state law is greater than was required by the 1978 Convention. A working knowledge of IMO Conventions concerning safety of life and protection of the marine environment is required. This includes Load Line, Tonnage, PAL, STP, SOLAS, MARPOL, STCW and ILO Minimum Standards in Merchant Ships Conventions. A knowledge of UNCLOS and international maritime law is also required.

Relatively new additions to maritime law should be noted including The ISM Code (R29) (incorporated as Ch IX of SOLAS, Management for the safe operation of ships); MARPOL 73/78, Annex I, regulation 26 that requires every oil tanker of 150gt and above and every ship other than a tanker of 400gt and above to have a shipboard oil pollution emergency plan and amendments to MARPOL Annex V that require garbage management plans to be in place.

Introduction to maritime law

Maritime questions are not confined to one country and therefore maritime law has always had an international bias. Historically, customary codes recognized in several countries were applied by the courts. In more recent years their place has been taken by international conventions, which are given force by national legislation enacted by the contracting States. Most maritime law is now statute law, particularly in the areas of safety and prevention of pollution.

Jurisdiction in public international law has been designed to allocate and delimit national sovereign powers. Each State has the right to legislate and enforce legislation on its own territory, subject to respecting other States' sovereignty and international law.

Ships spend much time on the high seas, over which no one has sovereignty, but these are treated as extensions of the flag State, which should exercise its jurisdiction and control in administrative, technical and social matters. The flag State has exclusive jurisdiction over those matters on the high seas. This is referred to as flag State jurisdiction. In general, international conventions specify the rights and duties of the flag State so that a State accepting a convention must enact legislation applicable to its own ships to give it the powers to enforce the provisions of the convention.

A State's power to control the activities of foreign ships in its territorial waters and contiguous zone is called coastal State jurisdiction. For example, a State may enforce rules regarding traffic separation schemes and anti-pollution measures within its territorial waters. The International Convention Relating to Intervention on the High Seas in Cases of Oil Pollution Casualties, 1969, gives a coastal State powers to take action in respect of a foreign ship on the high seas in special circumstances.

Port State jurisdiction refers to the power of a State to enforce rules and prosecute violations occurring within the jurisdiction of the port State. Many of the IMO conventions and a few ILO conventions include provisions giving rise to port State jurisdiction. The powers of the port State include inspection of certificates, inspection of the ship and in some cases detention of the ship.

The "no more favourable treatment" clause, mentioned in objective 4.6.1.1 provides that States parties are under the obligation to apply the relevant convention in the same manner to foreign ships flying the flag of a State which is not a party as to ships sailing under the flag of a State Party to the convention. The result is that ships flying the flags of non-party States will have to comply with the standards of those conventions when calling at ports of a State party.

Law of the sea - on the high seas

In 1958, four conventions were drawn up at the United Nations Conference on the Law of the Sea at Geneva. They were the Conventions on the Territorial Sea and the Contiguous Zone, on the High Seas, on the Continental Shelf, and on Fishing and Conservation of the Living Resources of the High Seas, all of which are currently in force.

The syllabus is concerned only with those parts of the first three of the conventions mentioned above which are relevant to the master in conducting a voyage.

The United Nations Convention on the Law of the Sea, 1982 (UNCLOS) embraces all aspects of the uses and resources of the oceans.

The Convention establishes a comprehensive framework for the regulation of all ocean space. Its provisions govern, amongst other things, the extent of national sovereignty or jurisdiction, the safety of navigation and the protection of the marine environment from pollution. It provides for the establishment of territorial seas up to 12 miles and an exclusive economic zone of up to 200 miles in breadth over which the coastal State has certain sovereign rights. Many States have given effect to these provisions. It also provides for special regimes that apply to navigation through straits and archipelagic waters.

The Convention entered into force on 16 November 1994. It will of course influence future international maritime conventions and recommendations to the extent that conflict with UNCLOS will be avoided and other measures may be introduced to give substance to certain of its provisions.

Force majeure is an exceptional circumstance which is irresistible, beyond anyone's power to resist even with foreknowledge. See the International Convention on Civil Liability for Oil Pollution Damage (1969), Article III, paragraph 2(a), which uses the expression "an act of war, hostilities, civil war, insurrection or a natural phenomenon of an exceptional, inevitable and irresistible character." They would be examples of *force majeure*, but this list is not necessarily exhaustive.

The expression "generally accepted international regulations, procedures and practices", or one of several similar expressions, is used in a number of the provisions. The Convention on the Law of the Sea does not give formal definitions for these expressions, and no clear guidelines are provided as to how the "international regulations and rules, etc.", referred to in the articles, may be identified. However, it appears to be generally accepted that the international regulations and standards adopted by IMO constitute a major component of the "generally accepted" international regulations and standards in matters relating to safety of navigation and the prevention and control of marine pollution from ships and by dumping.

Formal and authoritative interpretations of the provisions of UNCLOS can only be undertaken by the States parties to that Convention or, in appropriate cases, by the judicial or arbitral tribunals envisaged for that purpose in the convention itself.

Safety

Of all the international conventions dealing with maritime safety the most important is the International Convention for the Safety of Life at Sea, better known as SOLAS which covers a wide range of measures designed to improve the safety of shipping.

The convention is also one of the oldest of its kind: the first version was adopted in 1914 following the sinking of the SS Titanic with the loss of more than 1, 500 lives. Since then there have been four more versions of SOLAS. The present version was adopted in 1974 and entered into force in 1980.

Reference should be made to the International Safety Management (ISM) Code, which sets out the master's responsibility with regard to safety and environmental protection and in which the watchkeeping officer has a crucial role in discharge of these responsibilities.

International Convention on Load Lines

The Load Lines Protocol of 1988 will enter into force on 3 February 2000.

SOLAS - LSA Code

Instructors should note that the International Life-Saving Appliance (LSA) Code was adopted in 1996 and is now in force and mandatory. The Code gives technical and other details of personal life-saving appliances, visual signals, survival craft, rescue boats and other life-saving appliances (R30).

IMO has introduced amendments to harmonize the periods between surveys which will result in equal periods of validity of the different certificates in the near future. The Annex to these Guidance Notes shows bar diagrams of the harmonized system.

The first survey that a cargo ship undergoes by the flag State Administration is the initial survey. When the period of validity of a certificate expires, a renewal survey is required for the new certificate. The annual surveys have different names depending on the certificate involved.

In the future, the Cargo Ship Safety Construction, Safety Equipment and Safety Radio Certificates may be combined into the Cargo Ship Safety Certificate. This is an option under the SOLAS 1988 protocol which comes into force in February 2000.

Under 4.6.1.3, SOLAS sub-division and stability, trainees should only be expected to know the meaning and application of 'floodable length' and 'factor of subdivision', not the technical details of calculations.

In the section concerned with the SOLAS requirements for life-saving equipment, details of life-saving appliances, their equipment and their use are covered in IMO Model Courses 1.19, Proficiency in Personal Survival Techniques, and 1.23, Proficiency in Survival Craft and Rescue Boats other than Fast Rescue Boats.

Amendments to the 1974 SOLAS Convention and its Protocol of 1978 were adopted in 1988 to introduce the global maritime distress and safety system. The amendments entered into force, under the 'tacit acceptance' provisions of the SOLAS Convention and its 1978 Protocol, on 1 February 1992. Training requirements for the GMDSS general operator's certificate, see STCW regulation IV/2, are covered in IMO model course 1.25.

SOLAS - Carriage of grain

In many countries, the ship must also obtain a grain loading certificate, attesting that the ship has been loaded in accordance with the regulations, before sailing. Such certificates would be issued by an organization authorized by the Administration.

SOLAS - Carriage of dangerous goods

Details of the IBC and IGC codes are not required, but trainees should be aware of the survey and certification requirements. Officers who are to serve in chemical tankers or gas carriers will undertake appropriate specialized training.

STCW Code

The regulations and recommendations regarding the keeping of safe watches are fully covered in the STCW Convention, Chapter VIII. Trainees should be aware of the requirements concerning the certificates needed by ship's officers and other personnel and the port State control which may be applied.

ITU Radio Regulations

The International Telecommunication Union (ITU) is the United Nations Specialized Agency charged with the responsibility for all telecommunication matters, including management of the radiospectrum. The use of the radiospectrum is governed by the provisions the Radio Regulations.

IMO, in cooperation with ITU, the International Maritime Satellite Organization (Inmarsat), the COSPAS-SARSAT Partners, the World Meteorological Organization (WMO) and the International Hydrographic Organization (IHO), has developed a new system of maritime mobile radiocommunication services to replace the terrestrial Morse radiotelegraphy and radiotelephone-based system which in various forms has served the shipping industry since the early part of the twentieth century.

The new system, known as the Global Maritime Distress and Safety System (GMDSS), was phased in between 1 February 1992 and 1 February 1999. The system uses both terrestrial and satellite communications and is highly automated. As a result, extensive changes were introduced with respect to the training of personnel who are to operate the system and also with respect to those who may be required to maintain the system.

Passengers

Both the Special Trade Passenger Ships Agreement and the Protocol on Space Requirements refer to the International Health Regulations. The relevant sections are Article 84 and Annex V.

The Athens Convention entered into force on 28 April 1987.

4.7 Application of Leadership and Teamworking Skills

In today's highly demanding shipboard environment, the ship's officers are expected to act as managers and leaders to their crew and colleagues as well as interact with external parties. It is vital that they possess the knowledge and abilities of managing people, plan and coordinate activities on board as well as make the decisions through proper judgment and analysis of the situation at the time. At the same time, officers are required to ensure the company's objectives are achieved in a timely manner, thus he/she will require the knowledge and understanding of organizing and getting things done through others and in this instance, the teamworking skills are important in ensuring success.

Part C4: Detailed Teaching Syllabus

Introduction

The detailed teaching syllabus is presented as a series of learning objectives. The objective, therefore, describes what the trainee must do to demonstrate that the specified knowledge or skill has been transferred.

Thus each training outcome is supported by a number of related performance elements in which the trainee is required to be proficient. The teaching syllabus shows the *Required performance* expected of the trainee in the tables that follow.

In order to assist the instructor, references are shown to indicate IMO references and publications, textbooks and teaching aids that instructors may wish to use in preparing and presenting their lessons.

The material listed in the course framework has been used to structure the detailed teaching syllabus; in particular,

- Teaching aids (indicated by A);
- IMO references (indicated by R); and
- Textbooks (indicated by T).

will provide valuable information to instructors.

Explanation of Information Contained in the Syllabus Tables

The information on each table is systematically organized in the following way. The line at the head of the table describes the FUNCTION with which the training is concerned. A function means a group of tasks, duties and responsibilities as specified in the STCW Code. It describes related activities which make up a professional discipline or traditional departmental responsibility on board.

In this Model course there are four functions:

Marine engineering at the operational Level
Electrical, electronic and control engineering at the operational Level
Maintenance and repair at the operational Level
Controlling the operation of the ship and care for persons on board at the operational Level.

The header of the first column denotes the COMPETENCE concerned. Each function comprises a number of competences. For example, the Function 4, Controlling the Operation of the Ship and Care for Persons on Board at the Operational Level, comprises a number of COMPETENCES. Each competence is uniquely and consistently numbered in this model course.

In this function the competence is **Ensure compliance with pollution prevention requirements**. It is numbered 4.1, that is the first competence in Function 4. The term competence should be understood as the application of knowledge, understanding, proficiency, skills, and experience for an individual to perform a task, duty or responsibility on board in a safe, efficient and timely manner.

Shown next is the required TRAINING OUTCOME. The training outcomes are the areas of knowledge, understanding and proficiency in which the trainee must be able to demonstrate knowledge and understanding. Each COMPETENCE comprises a number of training

outcomes. For example, the above competence comprises two training outcomes. The first is concerned with the PRECAUTIONS TO BE TAKEN TO PREVENT POLLUTION OF THE MARINE ENVIRONMENT. Each training outcome is uniquely and consistently numbered in this model course. That concerned with precautions to be taken to prevent pollution of the marine environment is uniquely' numbered 4.1.1. For clarity training outcomes are printed in black on grey, for example TRAINING OUTCOME.

Finally, each training outcome embodies a variable number of Required performances-as evidence of competence. The instruction, training and learning should lead to the trainee meeting the specified Required performance. For the training outcome concerned with precautions to be taken to prevent pollution of the marine environment, there is just one area of performance. This is:

MARPOL 73/78

Following each numbered area of Required performance there is a list of activities that the trainee should complete and which collectively specify the standard of competence that the trainee must meet. These are for the guidance of teachers and instructors in designing lessons, lectures, tests and exercises for use in the teaching process. For example, under the topic 4.1.1.1, to meet the Required performance, the trainee should be able to:

- define for the purpose of MARPOL 73/78: a harmful substance, a discharge, and ship and an incident
- state that violations of the Convention are prohibited and that sanctions should be established for violations
- describes the inspections which may be made by Port State authorities and outlines actions which they may take

and so on.

IMO references (Rx) are listed in the column to the right hand side. Teaching aids (Ax), videos (Vx) and textbooks(Tx) relevant to the training outcome and required performance are placed immediately following the TRAINING OUTCOME title.

It is not intended that lessons are organized to follow the sequence of Required performances listed in the Tables. The Syllabus Tables are organized to match with the competence in the STCW Code TableA-III/1. Lessons and teaching should follow college practices. It is not necessary, for example, for celestial navigation to be studied before terrestrial and coastal navigation. What is necessary is that all the material is covered and that teaching is effective to allow trainees to meet the standard of the Required performance.

COMPETENCE 4.1	Ensure Compliance with Pollution-Prevention Requirements	IMO Reference
----------------	-------------------------------------------------------------	---------------

TRAINING OUTCOME

Demonstrates a knowledge and understanding of:

STCW Code
Table A-III/1

**4.1.1 THE PRECAUTIONS TO BE TAKEN TO PREVENT POLLUTION OF
THE MARINE ENVIRONMENT**

4.1.2 ANTI-POLLUTION PROCEDURES AND ALL ASSOCIATED EQUIPMENT

4.1.3 IMPORTANCE OF PROACTIVE MEASURES

COMPETENCE 4.1	Ensure Compliance with Pollution-Prevention Requirements	IMO Reference
----------------	-------------------------------------------------------------	---------------

4.1.1 THE PRECAUTIONS TO BE TAKEN TO PREVENT POLLUTION OF THE MARINE ENVIRONMENT

Textbooks: T31, T70
Teaching aids: A1, A2, V1, V2, V6

Required performance:

1.1 International Convention for the Prevention of Pollution from Ships, 1973 and the Protocol of 1978 relating thereto (MARPOL 73/78) (8 hours) R4

- defines, for the purpose of MARPOL 73/78:
 - harmful substance
 - discharge
 - ship
 - incident
- states that violations of the Convention are prohibited and that sanctions should be established for violations, wherever they occur by the Administration of the ship concerned
- describes the inspections which may be made by port State authorities and outlines actions which they may take
- describes the provisions for the detection of violations and enforcement of the Convention
- states that reports on incidents involving harmful substances must be made without delay

Annex I-Oil R5

- defines, for the purposes of Annex I:
 - oil
 - oily mixture
 - oil fuel
 - oil tanker
 - combination carrier
 - nearest land
 - special area
 - instantaneous rate of discharge of oil content
 - wing tank
 - centre tank
 - slop tank
 - clean ballast
 - segregated ballast
- describes the surveys and inspections required under the provisions of MARPOL 73/78
- describes the steps which may be taken if a surveyor finds that the condition of the ship or its equipment is unsatisfactory
- states that the condition of the ship and its equipment should be maintained to conform with the provisions of the Convention
- states that the certificate issued after survey is the International Oil Pollution Prevention (IOPP) Certificate
- states that the IOPP Certificate should be available on board the ship at all times
- lists the conditions under which oily mixtures may be discharged into the Sea from an oil tanker R6

- lists the conditions under which oily mixtures from machinery-space bilges may be discharged into the sea
- states that the provisions do not apply to the discharge of clean or segregated ballast
- describes the conditions under which the provisions do not apply to the discharge of oily mixtures from machinery spaces where the oil content without dilution does not exceed 15 parts per million
- states that residues which cannot be discharged into the sea in compliance with the regulations must be retained on board or discharged to reception facilities
- states that the special areas for the purposes of Annex I as the Antarctic area, the Baltic Sea area, Mediterranean sea area, Black Sea area, The Gulf area, Gulf of Aden area, Red Sea area and north-west European waters
- states that any discharge into the sea of oil or oily mixtures from an oil tanker or other ships of 400 tons gross tonnage and above is prohibited while in a special area
- describes the conditions under which a ship, other than an oil tanker, may discharge oily mixtures in a special area
- states that the regulation does not apply to the discharge of clean or segregated ballast
- describes conditions in which processed bilge water from machinery spaces may be discharged in a special area
- describes the exceptional circumstances in which the regulations on the discharge of oil or oily mixtures do not apply
- states that ballast water should not normally be carried in cargo tanks of tankers provided with segregated ballast tanks
- explains the exceptions in which ballast may be carried in cargo tanks
- states that every oil tanker operating with crude oil washing systems should be provided with an Operations and Equipment Manual
- states that, in new ships of 4, 000 tons gross tonnage and above and in new oil tankers of 150 tons gross tonnage and above, no ballast water should normally be carried in any oil fuel tank **Reg.14**
- describes the requirements for the provision of Oil Record Books **R4**
- lists the entries required for machinery space operations in part A of the Oil Record Book
- lists the entries required in respect of cargo or ballast operations in oil tankers
- describes the entries required for accidental or other exceptional discharge of oil
- states that the Oil Record Book should be kept on board readily available for inspection and should be preserved for a period of three years after the last entry has been made

Annex II - Noxious Liquid Substances in Bulk

R6

- describes the requirements of Annex II apply to all ships carrying noxious liquid substances in bulk
- states that noxious liquid chemicals are divided into four categories, X, Y, Z and OS such that substances in category X pose the greatest threat to the marine environment and those in category Z the least
- states that the conditions for the discharge of any effluent containing substances falling in those categories are specified
- states that more stringent requirements apply in special areas, which for the purposes of Annex II are the Baltic Sea area and the Black Sea area
- states that pumping and piping arrangements are to be such that, after unloading, the tanks designated for the carriage of liquids of category Z do not retain more than certain stipulated quantities of residue
- states that the discharge operations of certain cargo residues and certain tank-cleaning and ventilation operations may only be carried out in accordance with approved procedures and arrangements based on standards developed by IMO
- states that each ship which is certified for the carriage of noxious liquid

- substances in bulk should be provided with a Procedures and Arrangements Manual
- states that the Manual identifies the arrangements and equipment needed to comply with Annex II and specifies the operational procedures with respect to cargo handling, tank cleaning, slops handling, residue discharging, ballasting and deballasting which must be followed in order to comply with the requirements of Annex II
- states that each ship should be provided with a Cargo Record Book which should be completed, on a tank-by-tank basis, whenever any operations with respect to a noxious liquid substance take place
- states that a surveyor appointed or authorized by the Government of a Party to the Convention to supervise any operations under this Annex should make an appropriate entry in the Cargo Record Book
- describes the surveys required for ships carrying noxious liquid substances in bulk
- states that the certificate issued on satisfactory completion of the survey is an International Pollution Prevention Certificate for the Carriage of Noxious Liquid Substances in Bulk

Annex III-Harmful Substances Carried by Sea in Packaged Forms, or in Freight Containers, Portable Tanks or Road and Rail Tank Wagons **R4**

- states that for the purpose of this annex, empty receptacles, freight containers and portable road and rail tank wagons which have been used previously for the carriage of harmful substances are treated as harmful substances themselves unless precautions have been taken to ensure that they contain no residue that is hazardous to the marine environment
- states that packaging, containers and tanks should be adequate to minimize hazard to the marine environment
- describes the requirements for marking and labelling packages, freight containers, tanks and wagons
- describes the documentation relating to the carriage of harmful substances by sea
- states that certain harmful substances may be prohibited for carriage or limited as to the quantity which may be carried aboard any one ship
- states that jettisoning of harmful substances is prohibited except for the purpose of securing the safety of the ship or saving life at sea

Annex IV – Sewage **R4**

- describes the provisions regarding the discharge of sewage into the sea

Annex V – Garbage **R4**

- defines, for the purpose of Annex V:
 - garbage
 - nearest land
 - special area
- states that the provisions of Annex V apply to all ships
- states that the disposal into the sea of all plastics is prohibited
- states the regulations concerning the disposal of other garbage

Annex VI – Air Pollution

- defines, for the purposes of Annex VI:
 - continuous feeding
 - emission
 - new installations
 - NO_x technical code

- ozone depleting substances
- sludge oil
- shipboard incineration
- shipboard incinerator
- SO_x emission control area
- describes the types of inspection required under Annex VI
- describes the provision for the issuance of International Air Pollution Prevention certificate
- describes the duration of validity of the certificate
- describes the regulation regarding NO_x in regulation 13 of Annex VI
- describes the requirement for SO_x emission control area
- describes the requirement for fuel oil quality in regulation 18 of Annex VI

1.2 Convention of the Prevention of Marine Pollution by Dumping of Wastes and Other Matter (London Dumping Convention) (LDC) (2 hours) R4

- explains the aims of the Convention
- defines, for the purpose of the Convention:
 - dumping
 - wastes or other matter
 - special permit
 - general permit
- states that the dumping of wastes or other matter in whatever form or condition, as listed in annex I, is prohibited
- states that the dumping of wastes or other matter listed in annex II requires a prior special permit
- states that the dumping of all other wastes or matter requires a prior general permit
- states that the provisions of Article IV do not apply when it is necessary to secure the safety of human life or of vessels in cases of *force majeure* caused by stress of weather, or in any case which constitutes a danger to human life or a real threat to vessels
- states that such dumping should be done so as to minimize the likelihood of damage to human or marine life and must be reported immediately
- states that the Addendum to Annex I contains regulations on the incineration of wastes at sea
- states that the appropriate authority of a Contracting Party should issue prior special or general permits in respect of matter intended for dumping:
 - loaded in its territory
 - loaded by a vessel flying its flag when the loading occurs in the territory of a State not party to the Convention

1.3 International Convention Relating to Intervention on the High Seas in Cases of Oil Pollution Casualties, 1969 (1 hour) R4

- describes the rights of Parties to the Convention to intervene on the high seas following a maritime casualty

1.4 International Convention on Civil Liability for Oil Pollution Damage, 1969(CLC 1969)(1 hour) R4

- defines, for the purposes of the Convention:
 - ship
 - owner
 - oil
 - pollution damage

- preventive measures
 - incident
- describes the occurrences to which the Convention applies
- states that the owner of a ship is strictly liable for any oil pollution damage caused by the ship as the result of an incident
- lists the exceptions to liability

4.1.2 ANTI-POLLUTION PROCEDURES AND ALL ASSOCIATED EQUIPMENT R4

Textbooks:

Teaching aids: A1, A2, V6, V8

Required performance:

2.1 Basic knowledge of regulation 26 Annex I MARPOL 73/78

- describes the key points in a typical shipboard oil pollution emergency plan

2.2 Basic knowledge of anti-pollution equipment required by national legislation

- for example, lists the equipment required under OPA 90 of the United States

4.1.3 IMPORTANCE OF PROACTIVE MEASURES (2 hours)

R1, R4

Textbooks:

Teaching aids: A1, A2, V6

Required performance:

- describes the importance of proactive measures to protect the marine environment in terms of compliance with the concerning international and national laws or regulations
- describes the responsibilities of master, officer and rating each on board for protecting the marine environment
- describes the impacts on marine environment brought about by pollution substances
- explains what tasks concerning pollution substances are carried out on board ships
- lists actual proactive measures to be taken on board ships when:
 - bunkering
 - transferring oil and other pollution substances
 - disposing of waste

COMPETENCE 4.2	Maintain the Seaworthiness of the Ship	IMO Reference
----------------	----------------------------------------	---------------

TRAINING OUTCOME		STCW Code Table A–III/1
------------------	--	----------------------------

Demonstrates a knowledge and understanding of:

- | | |
|-------------------------------------------------------------------------------------------------------------------------------------------------------------------------------------------------------------------------------|-------------------|
| 4.2.1 STABILITY, TRIM AND STRESS TABLES, DIAGRAMS AND STRESS–CALCULATING EQUIPMENT, AND ACTION TO BE TAKEN IN THE EVENT OF PARTIAL LOSS ON INTACT BUOYANCY. UNDERSTANDING OF THE FUNDAMENTALS OF WATER–TIGHT INTEGRITY | R1, R2, R3 |
| 4.2.2 THE PRINCIPAL STRUCTURAL MEMBERS OF A SHIP AND THE PROPER NAMES FOR VARIOUS PARTS | |

COMPETENCE 4.2	Maintain the Seaworthiness of the Ship	IMO Reference
----------------	----------------------------------------	---------------

4.2.1 STABILITY, TRIM AND STRESS TABLES

Textbooks: T11, T58

Teaching aids: A1, V3

Required performance:

SHIP STABILITY

1.1 Displacement (4 hours)

R1

- states that, for a ship to float, it must displace a mass of water equal to its own mass
- explains how, when the mass of a ship changes, the mass of water displaced changes by an equal amount
- states that the displacement of a vessel is its mass and it is measured in tonnes
- states that displacement is represented by the symbol Δ
- explains the relationship between the displacement and mean draught of a ship by using the graph or scale
- given a displacement/draught curve, finds:
 - displacements for given mean draughts
 - mean draughts for given displacements
 - the change in mean draught when given masses are loaded or discharged
 - the mass of cargo to be loaded or discharged to produce a required change of draught
- defines 'light displacement' and 'load displacement'
- defines 'deadweight'
- uses a deadweight scale to find the deadweight and displacement of a ship at various draughts in seawater
- defines 'tonnes per centimetre immersion'(TPC)
- explains why TPC varies with different draughts
- uses a deadweight scale to obtain TPC at given draughts
- uses TPC obtained from a deadweight to find:
 - the change of mean draught when given masses are loaded or discharged
- the mass of cargo to be loaded or discharged to produce a required change of draught
- defines 'block coefficient'(C_b)
- calculates C_b from given displacement and dimensions
- calculates displacement from given C_b and dimensions

1.2 Buoyancy (2 hours)

R1

- explains what is meant by 'buoyancy'
- states that the force of buoyancy is an upward force on a floating object created by the pressure of liquid on the object
- states that the buoyancy force is equal to the displacement of a floating object
- describes reserve buoyancy
- explains the importance of reserve buoyancy
- explains how freeboard is related to reserve buoyancy
- explains the purpose of load lines
- explains the requirements for maintaining watertight integrity
- demonstrates an understanding of damage stability requirements for certain vessels
- explains reasons for damage stability requirements
- identifies damage stability requirements for Type A vessels, Type (B–60)and Type (B–100) vessels

R1
Section A-V/2

- identifies equilibrium condition after flooding for Type A, and all Type B vessels
- identifies damage stability requirements for passenger vessels

1.3 Fresh Water Allowance (3 hours)

R1

- explains why the draught of a ship decreases when it passes from fresh water to seawater and vice versa
- states that when loading in fresh water before proceeding into seawater, a ship is allowed a deeper maximum draught
- describes what it meant by the fresh water allowance (FWA)
- given the FWA and TPC for fresh water, calculates the amount which can be loaded after reaching the summer load line when loading in fresh water before sailing into seawater
- describes the uses a hydrometer to find the density of dock water
- describes the effect of changes of tide and rain on dock water density
- explains how to obtain the correct dock water density
- given the density of dock water and TPC for seawater, calculates the TPC for dock water
- given the density of dock water and FWA, calculates the amount by which the appropriate load line may be submerged
- given the present draught amidships and the density of dock water, calculates the amount to load to bring the ship to the appropriate load line in seawater

1.4 Statical Stability (3 hours)

R1

- states that weight is the force of gravity on a mass and always acts vertically downwards
- states that the total weight of a ship and all its contents can be considered to act at a point called the centre of gravity (G)
- states that the centre of buoyancy (B) as being the centre of the underwater volume of the ship
- states that the force of buoyancy always acts vertically upwards
- explains that the total force of buoyancy can be considered as a single force acting through B
- states that when the shape of the underwater volume of a ship changes the position of B also changes
- states that the position of B will change when the draught changes and when heeling occurs
- labels a diagram of a midship cross-section of an upright ship to show the weight acting through G and the buoyancy force acting through B
- states that the buoyancy force is equal to the weight of the ship
- labels a diagram of a midship cross-section of a ship heeled to a small angle to show the weight acting through G and the buoyancy force acting through B
- describes stability as the ability of the ship to return to an upright position after being heeled by an external force
- states that the lever GZ as the horizontal distance between the vertical forces acting through B and G
- states that the forces of weight and buoyancy form a couple
- states that the magnitude of the couple is displacement \times lever, $\Delta \times GZ$
- explains how variations in displacement and GZ affect the stability of the ship
- on a diagram of a heeled ship, shows:
 - the forces at B and G
 - the lever GZ
- states that the length of GZ will be different at different angles of heel
- states that if the couple $\Delta \times GZ$ tends to turn the ship toward the upright, the ship is stable
- states that for a stable ship:

- $\Delta \times GZ$ is called the righting moment
- GZ is called the righting lever

1.5 Initial Stability (4 hours)

R1

- states that it is common practice to describe the stability of a ship by its reaction to heeling to small angles (up to approximately 10°)
- defines the transverse metacentre (M) as the point of intersection of successive buoyancy force vectors as the angle of heel increases by a small angle
- states that, for small angles of heel, M can be considered as a fixed point on the centreline
- on a diagram of a ship heeled to a small angle, indicates G, B, Z and M
- shows on a given diagram of a stable ship that M must be above G and states that the metacentric height GM is taken as positive
- shows that for small angles of heel (θ), $GZ = GM \times \sin\theta$
- states that the value of GM is a useful guide to the stability of a ship
- describes the effect on a ship's behaviour of:
 - a large GM (stiff ship)
 - a small GM (tender ship)
- uses hydrostatic curves to find the height of the metacentre above the keel (KM) at given draughts
- states that KM is only dependent on the draught of a given ship
- given the values of KG, uses the values of KM obtained from hydrostatic curves to find the metacentre heights, GM
- states that, for a cargo ship, the recommended initial GM should not normally be less than 0.15m

1.6 Angle of Loll (1 hour)

R1

- shows that if G is raised above M, the couple formed by the weight and buoyancy force will turn the ship further from the upright
- states that in this condition, GM is said to be negative and $\Delta \times GZ$ is called the upsetting moment or capsizing moment
- explains how B may move sufficiently to reduce the capsizing moment to zero at some angle of heel
- states that the angle at which the ship becomes stable is known as the angle of loll
- states that the ship will roll about the angle of loll instead of the upright
- states that an unstable ship may loll to either side
- explains why the condition described in the above objective is potentially dangerous

1.7 Curves of Statical Stability (4 hours)

R1

- states that for any one draught the lengths of GZ at various angles of heel can be drawn as a graph
- states that the graph described in the above objective is called a curve of statical stability
- states that different curves are obtained for different draughts with the same initial GM
- identifies cross curves (KN curves and MS curves)
 - derives the formula $GZ = MS + GM \sin\theta$
 - derives the formula $GZ = KN - KG \sin\theta$
 - derives GZ curves for stable and initially unstable ships from KN curves
 - from a given curve of statical stability obtains:
 - the maximum righting lever and the angle at which it occurs

- the angle of vanishing stability
- the range of stability
- shows how lowering the position of G increases all values of the righting lever and vice versa
- states that angles of heel beyond approximately 40° are not normally of practical interest because of the probability of water entering the ship at larger angles

1.8 Movement of the Centre of Gravity (4 hours)

R1

- states that the centre of gravity (G) of a ship can move only when masses are moved within, added to, or removed from the ship
- states that:
 - G moves directly towards the centre of gravity of added masses
 - G moves directly away from the centre of gravity of removed masses
 - G moves parallel to the path of movement of masses already on board
- calculates the movement of G (GG_1) from:

$$GG_1 = \frac{\text{mass added or removed} \times \text{distance of mass from G}}{\text{new displacement of the ship}}$$

$$GG_1 = \frac{\text{mass moved} \times \text{distance mass is moved}}{\text{displacement of the ship}}$$

- performs calculations as in the above objective to find the vertical and horizontal shifts of the centre of gravity resulting from adding, removing or moving masses
- states that if a load is lifted by using a ship's derrick or crane, the weight is immediately transferred to the point of suspension
- states that if the point of suspension is moved horizontally, the centre of gravity of the ship also moves horizontally
- states that if the point of suspension is raised or lowered, the centre of gravity of the ship is raised or lowered
- calculates, by using moments about the keel, the position of G after loading or discharging given masses at stated positions
- calculates the change in KG during a passage resulting from:
 - consumption of fuel and stores
 - absorption of water by a deck cargo
 - accretion of ice on decks and superstructures given the masses and their positions

1.9 List and its Correction (6 hours)

R1

- shows on a diagram the forces which cause a ship to list when G is to one side of the centreline
- states that the listing moment is given by displacement \times transverse distance of G from the centreline
- shows on a diagram that the angle of list (θ) is given by
$$\tan\theta = \frac{GG_1}{GM}$$
 where GG_1 is the transverse shift of G from the centreline
- states that in a listed condition the range of stability is reduced
- given the displacement, KM and KG of a ship, calculates the angle of list resulting from loading or discharging a given mass at a stated position, or from moving a mass through a given transverse distance
- explains, with reference to moments about the centreline, how the list may be removed
- given the displacement, GM and the angle of list of a ship, calculates the mass to load or discharge at a given position to bring the ship upright
- given the displacement, GM and angle of list of a ship, calculates the mass to

- move through a given transverse distance to bring the ship upright
- given the draught, beam and rise of the floor, calculates the increase in draught resulting from a stated angle of list

1.10 Effect of Slack Tanks (3 hours)

R1

- states that if a tank is full of liquid, its effect on the position of the ship's centre of gravity is the same as if the liquid were a solid of the same mass
- explains by means of diagrams how the centre of gravity of the liquid in a partly filled tank moves during rolling
- states that when the surface of a liquid is free to move, there is a virtual increase in KG, resulting in a corresponding decrease in GM
- states that the increase in KG is affected mainly by the breadth of the free surface and is not dependent upon the mass of liquid in the tank
- states that in tankers the tanks are often constructed with a longitudinal subdivision to reduce the breadth of free surface

1.11 Trim (6 hours)

R1

- states that "trim" is the difference between the draught aft and the draught forward
- states that trim may be changed by moving masses already on board forward or aft, or by adding or removing masses at a position forward of or abaft the centre of flotation
- states that 'centre of flotation' is the point about which the ship trims, and states that it is sometimes called the tipping centre
- states that the centre of flotation is situated at the centre of area of the waterplane, which may be forward of or abaft amidships
- demonstrates the uses hydrostatic data to find the position of the centre of flotation for various draughts
- states that a trimming moment as mass added or removed \times its distance forward or aft of the centre of flotation; or, for masses already on board, as mass moved \times the distance moved forward or aft
- states that the moment to change trim by 1 cm (MCT 1cm) as the moment about the centre of flotation necessary to change the trim of a ship by 1 cm
- demonstrates the uses hydrostatic curves or deadweight scale to find the MCT 1cm for various draughts
- given the value of MCT 1cm, masses moved and the distances moved forward or aft, calculates the change in trim
- given the value of MCT 1 cm, the position of the centre of flotation, masses added or removed and their distances forward of or abaft the centre of flotation, calculates the change of trim
- given initial draughts and the position of the centre of flotation, extends the calculation in the above objective to find the new draughts
- given initial draughts and TPC, extends the calculation in the above objective to find the new draughts
- given initial draughts and TPC, extends the calculation to find the new draughts
- demonstrates the uses of a trimming table or trimming curves to determine changes in draughts resulting from loading, discharging or moving weights
- states that in cases where the change of mean draught is large, calculation of change of trim by taking moments about the centre of flotation or by means of trimming tables should not be used
- calculates final draughts and trim for a planned loading by considering changes to a similar previous loading

R1

1.12 Actions to be Taken in the Event of Partial Loss of Intact Buoyancy (1 hour) R1

- states that flooding should be countered by prompt closing of watertight doors, valves and any other openings which could lead to flooding of other compartments
- states that cross–flooding arrangements, where they exist, should be put into operation immediately to limit the resulting list
- states that any action which could stop or reduce the inflow of water should be taken

4.2.2 THE PRINCIPAL STRUCTURAL MEMBERS OF A SHIP

Textbooks: T58

Teaching aids: A1

Required performance:

SHIP CONSTRUCTION (63 hours)

2.1 Ship Dimensions and Form (12 hours) R1

- illustrates the general arrangement of the following ship types:
 - general cargo
 - tankers
 - bulk carriers
 - combination carriers
 - container
 - RO-RO
 - passenger
- reproduces an elevation of a general cargo ship, showing holds, engine–room, peak tanks, double–bottom tanks, hatchway, tween deck and position of bulkheads
- reproduces an elevation of a typical crude oil carrier, showing bulkheads, cofferdams, pump–room, engine–room, bunker and peak tanks, cargo tanks, slop tank and permanent ballast tanks
- reproduces a plan view of a tanker, showing the arrangement of cargo and ballast tanks
- defines and illustrates:
 - camber
 - rise of floor
 - tumblehome
 - flare
 - sheer
 - rake
 - parallel middle body
 - entrance
 - run
- defines:
 - forward perpendicular(FP)
 - after perpendicular (AP)
 - length between perpendiculars(LBP)
 - length on the waterline (LWL)
 - length overall (LOA)
 - base line
 - moulded depth, beam and draught
 - extreme depth, beam and draught

2.2 Ship Stresses (8 hours)

R1

- describes in qualitative terms shear force and bending moments
- explains what is meant by 'hogging' and by 'sagging' and distinguishes between them
- describes the loading conditions which give rise to hogging and sagging stresses
- describes how hogging and sagging stresses are caused by the sea state
- explains how hogging and sagging stresses result in tensile or compressive forces in the deck and bottom structure
- describes water pressure loads on the ship's hull
- describes liquid pressure loading on the tank structures
- calculates the pressure at any depth below the liquid surface, given the density of the liquid
- describes qualitatively the stresses set up by liquid sloshing in a partly filled tank
- describes racking stress and its causes
- explains what is meant by 'panting' and states which part of the ship is affected
- explains what is meant by 'pounding' or 'slamming' and states which part of the ship is affected
- describes stresses caused by localized loading
- demonstrates understanding of modern methods of determining the effects of different loading and ballasting on the ship's structure
- demonstrates ability to use one of the modern mechanical or electrical aids for determining stress
- understands the input and output data from stress calculation machines and has a working knowledge of the stress tables
- states the purpose of a shipboard stress finding system, including details of input data and the output obtained
- describes how output data from ship stress finding system may be used
- appreciates torsion stress particularly with reference to container ship loading
- analyses the stress areas created by bending moments and shearing forces derived by a stress indicator
- analyses the causes and effects of shearing forces and bending moments on ships' structures
- defines bending moment as the difference between moment of buoyancy and moment of weight
- defines shearing forces in terms of the difference between buoyancy and weight
- extracts information from shear force and bending moment diagrams
- describes the constructional features which compensate for stress
- describes corrosion
- describes the causes of corrosion on board
- describes the various methods that being used to minimize the effect of corrosion

2.3 Hull Structure (11 hours)

R1

- identifies structural components on ships' plans and drawings:
 - frames, floors, transverse frames, deck beams, knees, brackets
 - shell plating, decks, tank top, stringers
 - bulkheads and stiffeners, pillars
 - hatch girders and beams, coamings, bulwarks
 - bow and stern framing, cant beams, breasthooks
- describes the types of materials that are used in the construction of a ship
- describes and illustrates standard steel sections:
 - flat plate
 - offset bulb plate

- equal angle
- unequal angle
- channel
- tee
- describes with aids of sketches the longitudinal, transverse and combined systems of framing on transverse sections of the ships
- sketches the arrangement of frames, webs and transverse members for each system
- illustrates double-bottom structure for longitudinal and transverse framing
- illustrates hold drainage systems and related structure
- illustrates a duct keel
- sketches the deck edge, showing attachment of sheer strake and stringer plate
- sketches a radiused sheer strake and attached structure
- describes the stress concentration in the deck round hatch openings
- explains compensation for loss of strength at hatch openings
- sketches a transverse section through a hatch coaming, showing the arrangement of coamings and deep webs
- sketches a hatch corner in plain view, showing the structural arrangements
- sketches deck-freeing arrangements, scuppers, freeing ports, open rails
- illustrates the connection of superstructures to the hull at the ship's side
- sketches a plane bulkhead, showing connections to deck, sides and double bottom and the arrangement of stiffeners
- sketches a corrugated bulkhead
- explains why transverse bulkheads have vertical corrugations and fore-and-aft bulkheads have horizontal ones
- describes the purpose of bilge keels and how they are attached to the ship's side

R1

2.4 Bow and Stern (6 hour)

R1

- describes the provisions of additional structural strength to withstand pounding
- describes and illustrates the structural arrangements forward to withstand panting
- describes the function of the sternframe
- describes and sketches a sternframe for a single-screw ship
- describes and illustrates the construction of a transom stern, showing the connections to the sternframe

R1

2.5 Fittings (10 hours)

- describes and sketches an arrangement of modern weather-deck mechanical steel hatches
- describes how watertightness is achieved at the coamings and cross joints
- describes the cleating arrangements for the hatch covers
- describes the arrangement of portable beams, wooden hatch covers and tarpaulins
- sketches an oiltight hatchcover
- describes roller, multi-angle, pedestal and Panama fairleads
- sketches mooring bits, showing their attachment to the deck
- sketches typical forecastle mooring and anchoring arrangements, showing the leads of moorings
- describes the construction and attachment to the deck of tension winches and explains how they are used
- describes the anchor handling arrangements from hawse pipe to spurling pipe
- describes the construction of chain lockers and how the bitter-ends are secured in the lockers
- explains how to secure anchors and make spurling pipes watertight in preparation for a sea passage
- describes the construction and use of a cable stopper

- describes the construction of masts and Sampson posts and how they are supported at the base
- describes the construction of derricks and deck cranes
- describes the bilge piping system of a cargo ship
- states that each section is fitted with a screw-down nonreturn suction valve
- describes and sketches a bilge strum box
- describes a ballast system in a cargo ship
- describes the arrangement of a fire main and states what pumps may be used to pressurize it
- describes the provision of sounding pipes and sketches a sounding pipe arrangement
- describes the fitting of air pipes to ballast tanks or fuel oil tanks
- describes the arrangement of fittings and lashings for the carriage of containers on deck

2.6 Rudder and Propellers (11 hours)

R1

- describes the action of the rudder in steering a ship
- reproduces drawings of modern rudders: semi balanced, balanced and spade
- explains the purpose of the rudder carrier and pintles
- explains how the weight of the rudder is supported by the rudder carrier
- describes the rudder trunk
- describes the arrangement of a watertight gland round the rudder stock
- explains the principle of screw propulsion
- describes a propeller and defines, with respect to :
 - boss
 - rake
 - skew
 - face
 - back
 - tip
 - radius
 - pitch
- compares fixed-pitch with controllable-pitch propellers
- sketches the arrangement of an oil-lubricated stern tube and tailshaft
- describes how the propeller is attached to the tailshaft
- sketches a cross-section of a shaft tunnel for water cooled and oil cooled type
- explains why the shaft tunnel must be of watertight construction and how water is prevented from entering the engine-room if the tunnel becomes flooded

2.7 Load Lines and Draught Marks (5 hours)

R1, R3

- explains where the deck line is marked
- defines 'freeboard'
- explains what is meant by 'assigned summer freeboard'
- draws to scale the load line mark and the load lines for a ship of a given summer moulded draught, displacement and tonnes per centimetre immersion in salt water
- explains how the chart of zones, areas and seasonal periods is used to find the applicable load line
- demonstrates how to read draughts
- explains that the freeboard, measured from the upper edge of the deck line to the water on each side, is used to check that the ship is within its permitted limits of loading

COMPETENCE 4.3	Prevent, Control and Fight Fires on Board	IMO Reference
----------------	-------------------------------------------	---------------

TRAINING OUTCOME

Demonstrates a knowledge and understanding of:

STCW Code
Section A-VI/3

4.3.1 FIRE PREVENTION

4.3.2 ORGANISING FIRE DRILLS

4.3.3 CHEMISTRY OF FIRE

4.3.4 FIRE –FIGHTING SYSTEMS

**4.3.5 THE ACTION TO BE TAKEN IN THE EVENT OF FIRE,
INCLUDING FIRES INVOLVING OIL**

See IMO ModelCourse No2.03 and the requirements of STCW
TableA –VI/3 for Competence in Advanced Fire –fighting

STCW Code
Table A-VI/3

COMPETENCE 4.4	Operate life-saving Appliances	IMO Reference
----------------	--------------------------------	---------------

TRAINING OUTCOME

Demonstrates a knowledge and understanding of

4.4.1 ORGANIZING ABANDON SHIP DRILLS AND THE OPERATION OF SURVIVAL CRAFT AND RESCUE BOATS, THEIR LAUNCHING APPLIANCES AND ARRANGEMENTS, THEIR EQUIPMENT, INCLUDING RADIO LIFE-SAVING APPLIANCES, SATELLITE EPIRBs, SARTs, IMMERSION SUITS AND THERMAL PROTECTIVE AIDS

STCW Code
Section A-VI/2
para 1-2

4.4.2 SURVIVAL AT SEA TECHNIQUES

See IMO Model Course 1.23, and the requirements of STCW Table A-VI/2-1 for Competence in Survival Craft and Rescue Boats other than Fast Rescue Boats

STCW Code
Table A-VI/2-1

COMPETENCE4.5	Apply Medical First Aid on Board Ship	IMO Reference
---------------	---------------------------------------	---------------

TRAINING OUTCOME

Demonstrates a knowledge and understanding of

**4.5.1 PRACTICAL APPLICATION OF MEDICAL GUIDES AND
ADVICE BY RADIO, INCLUDING THE ABILITY TO TAKE
EFFECTIVE ACTION BASED ON SUCH KNOWLEDGE IN
THE CASE OF ACCIDENTS OR ILLNESSES THAT ARE
LIKELY TO OCCUR ON BOARD SHIP**

**STCW Code
Section A-VI/4
Para 1-6**

See IMO Model Course 1.14 and the requirements of STCW
Table A-VI/4-1 for Proficiency in Medical First Aid

STCW Code
Table A-VI/4

COMPETENCE 4.6	Monitor Compliance with Legislative Requirements	IMO Reference
----------------	--------------------------------------------------	---------------

TRAINING OUTCOME

STCW Code
Table A-III/1

Demonstrates a knowledge and understanding of :

**4.6.1 IMO CONVENTIONS CONCERNING SAFETY OF LIFE AT
SEA AND PROTECTION OF THE MARINE ENVIRONMENT**

R1

4.6.1 IMO CONVENTIONS CONCERNING SAFETY OF LIFE AT SEA AND PROTECTION OF THE MARINE ENVIRONMENT

Textbooks: T19

Teaching aids: A1, A2, V4, V5, V8

Required performance:

1.1 Introduction to Maritime Law (1 hour)

- states that maritime law is based partly on generally accepted customary rules developed over many years and partly on statute law enacted by states
- states that matters of safety, protection of the marine environment and conditions of employment are covered by statute law
- states that the main sources of maritime law are international conventions
- states that the adoption of international conventions and agreements is intended to provide uniform practice internationally
- states that a convention is a treaty between the States which have agreed to be bound by it to apply the principles contained in the convention within their sphere of jurisdiction
- states that, to implement a convention or other international agreement, a State must enact national legislation giving effect to and enforcing its provisions
- states that recommendations which are not internationally binding may be implemented by a State for ships flying its flag
- lists the main originators of international conventions concerned with maritime law are:
 - International Maritime Organization (IMO)
 - International Labour Organization (ILO)
 - Comite Maritime International (CMI)
 - United Nations
- describes briefly:
 - flag State jurisdiction
 - coastal State jurisdiction
 - port State jurisdiction
- describes main elements of relevant IMO Conventions, e.g. SOLAS, MARPOL and STCW **R1,R2,R4**
- explains the significance of the 'no more favourable treatment' clause in the SOLAS, MARPOL, STCW and ILO Minimum Standards in Merchant Ships Conventions
- distinguishes between private and public international law
- explains that public maritime law is enforced through:
 - surveys, inspection and certification
 - penal sanctions (fines, imprisonment)
 - administrative procedures (inspection of certificates and records, detention)
- states that the operation of a ship is governed by the national laws and regulations of the flag State, including those laws and regulations giving effect to international conventions
- states that differences of detail usually exist in the national laws of different states implementing the same convention
- states that, when serving in a ship flying a foreign flag, it is essential that the master and chief mate familiarize themselves with the laws and regulations of the flag State
- states that, when in port, a ship must also comply with the appropriate laws and regulations of the port State
- describes the importance of keeping up to date with developments in new and amended legislation

1.2 Law of the Sea (7 hours)

R8, R9

Conventions on the Law of the Sea (0.5 hour)

- states that the law of the sea is embodied in the Geneva Conventions of 1958 and the United Nations Convention on the Law of the Sea, 1982 (UNCLOS)
- describes the legal status of UNCLOS
- describes the legal status of the Geneva Conventions
- describes the pollution of the marine environment
- defines dumping
- defines 'force majeure'

Territorial Sea and the Contiguous Zone (2 hours)

R8, R9

- describes the legal status of the territorial sea and its breadth
- defines 'internal waters'
- describes the legal status of roadsteads
- describes the right of innocent passage
- defines 'passage'
- defines innocent passage'
- lists matters on which coastal State laws or regulations may affect innocent passage
- describes the obligations during innocent passage in a territorial sea
- describes the use of sea lanes and traffic separation schemes (TSS) in the territorial sea
- describes the obligations of nuclear-powered ships and ships carrying dangerous or noxious substances
- describes the additional rights of a coastal State regarding ships proceeding to internal waters or calling at a port facility
- describes the charges which may be levied on ships passing through a territorial sea
- describes the criminal jurisdiction of a coastal State on board a foreign ship passing through the territorial sea
- states that a coastal State may take any steps authorized by its laws for the purpose of an arrest or investigation on board a foreign ship passing through the territorial sea after leaving internal waters
- explains the coastal State's obligation to facilitate contact between the consular authority of the flag State and the ship's crew when taking measures to arrest a ship
- states that the coastal State may not take any steps on board a foreign ship passing through the territorial sea to arrest any person or to conduct any investigation in connection with any crime committed before the ship entered the territorial sea if the ship, proceeding from a foreign port, is only passing through the territorial sea without entering internal waters
- describes the civil jurisdiction of a coastal State on board a foreign ship passing through the territorial sea
- describes the extent of the contiguous zone and the control a coastal State may exercise therein

International Straits (1 hour)

R8, R9

- describes the legal status of waters forming straits used for international navigation
- describes the right of transit passage
- defines 'transit passage'
- describes the duties of ships in transit passage
- explains the meaning of 'generally accepted international regulations, procedures and practices'
- describes the duty of ships in transit passage regarding sea lanes and TSS
- lists matters on which coastal State laws or regulations may affect transit passage

- describes the obligations of ships during transit passage
- describes the application of innocent passage to straits used for international navigation
- defines 'archipelago'
- defines 'archipelagic state'
- describes the right of innocent passage through archipelagic waters
- states that an archipelagic State may designate sea lanes through its waters
- describes how sea lanes should be defined and how ships should follow them
- states that an archipelagic State may designate TSS for any sea lanes
- states that ships must respect established sea lanes and TSS
- states that the laws and regulations which may be made by an archipelagic State relating to sea lanes and the obligations of ships during their passage are the same as those relating to the transit of international straits

Exclusive Economic Zone and Continental Shelf (0.5 hour)

R8, R9, R10

- defines the exclusive economic zone and states its breadth
- defines continental shelf
- describes the coastal State's jurisdiction over artificial islands, installations and structures within its exclusive economic zone
- explains the establishment of safety zones around artificial islands, installations and structures and states the breadth of those zones
- describes the obligations of ships regarding safety zones

High Seas (2 hours)

R8, R9

- describes the freedom of the high seas
- explains the nationality of ships
- states that each State must issue to ships to which it has granted the right to fly its flag documents to that effect
- states that, except in exceptional circumstances, ships must sail under the flag of one State only and be subject to its exclusive jurisdiction
- states that a ship may not change its flag during a voyage or while in a port of call, save in case of real transfer of ownership or change of registry
- explains the status of ships regarding nationality
- describes the duties of the flag State with respect to ships flying its flag
- states that in taking such measures each State is required to conform to generally accepted international standards
- states that in the event of a collision or of any other incident of navigation no penal or disciplinary proceedings may be instituted except before the judicial authorities either of the flag State or of the State of which such a person is a national
- explains who may withdraw a master's certificate or a certificate of competence or a licence
- states that no arrest or detention of a ship, even as a measure of investigation, may be ordered by any authorities other than those of the flag State
- states that every State must require the master of a ship sailing under its flag, to render assistance to any person found at sea in danger of being lost, and, after a collision, to render assistance to the other ship, her crew and her passengers and, where possible, to inform the other ship of the name of his own ship, her port of registry and the nearest, port at which she will call
- states that the breaking or injury of submarine cables so as to interrupt or obstruct telegraphic or telephonic communications, and similarly the breaking or injury of a submarine pipeline or high-voltage power cable, is, except for the purpose of saving lives or ships, a punishable offence
- states that the owners of ships who can prove that they have sacrificed an anchor, a net or any other fishing gear in order to avoid injuring a submarine cable or pipeline should be indemnified by the owner of the cable or pipeline

Protection and Preservation of the Marine Environment (1 hour) R8, R9

- explains the rights of coastal States to adopt laws and regulations for the prevention, reduction and control of pollution in respect of their exclusive economic zones
- summarizes the enforcement by flag States of measures for the prevention, reduction and control of pollution from ships
- summarizes the enforcement by port States of measures for the prevention, reduction and control of pollution from ships
- describes the measures relating to seaworthiness of vessels to avoid pollution
- summarizes the enforcements by coastal States of measures for the prevention, reduction and control of pollution from ships
- states the rights of States to take and enforce measures beyond their territorial seas to avoid pollution arising from maritime casualties
- defines 'maritime casualty'
- states that when the United Nations Convention on the Law of the Sea (UNCLOS) entered in force in 1994 it replaced the four Geneva Conventions on the Law of the Sea, 1958
- states that UNCLOS does not alter the rights and obligations of States Parties which arise from other agreements compatible with that Convention

1.3 Safety (24 hours)

**International Convention on Load Lines, 1966 (LL 1966), as amended R3, R11
(3 hours)**

- states that no ship to which the Convention applies may proceed to sea on an international voyage unless it has been surveyed, marked and provided with an international Load Line Certificate (1966) or an international Load Line Exemption Certificate, if appropriate
- explains to which ships the Convention applies
- describes the duration of validity of an International Load Line Certificate (1966)
- explains the circumstances in which an International Load Line Certificate (1966) would be cancelled by the Administration
- states the control to which ships holding an international Load Line Certificate (1966) are subject when in the ports of other Contracting Governments
- describes for the purposes of the Regulations concerning:
 - freeboard
 - freeboard deck
 - superstructure
- describes the position, dimensions and marking of:
 - the deck line
 - the Load Line Mark
 - lines to be used with the Load Line Mark
- states that the circle lines and letters are to be painted in white or yellow on a dark ground or in black on a light ground and that they should be permanently marked on the sides of the ship
- states that the international Load Line Certificate (1966) will not be delivered to a ship until the surveyor has certified that the marks are correctly and permanently indicated on the ship's sides
- explains the terms 'position 1' and 'position 2' with regard to the positions of hatchways, doorways and ventilators
- states that hatchway covers made of mild steel are constructed for assumed loads or not less than 1.75 tonnes/m² in position 1 and of not less than 1.30 tonnes/m² in position 2
- describes the requirements concerning the provision of closing appliances for

- ventilators
- states that means, permanently attached, should be provided for closing the openings of air pipes to ballast tanks and other tanks
- describes the provisions for the protection of the crew
- states that deck cargo should be so stowed as to allow for the closing of openings giving access to crew's quarters, machinery space and other parts used in the necessary work of the ship

International Convention for the Safety of Life at Sea, 1974 as amended (SOLAS) –General Provisions (2 hours) R2

- states that unless expressly provided otherwise, the regulations apply only to ships engaged on international voyages
- defines 'international voyage'
- defines:
 - passenger
 - passenger ship
 - cargo ship
 - tanker
 - age of a ship
- explains who may carry out surveys for the enforcement of the provisions of SOLAS
- describes the powers of a nominated surveyor
- describes the procedures which apply if the surveyor finds that the ship does not comply with the provisions or is in such a condition that it is not fit to proceed to sea without danger to the ship or to persons on board
- lists the surveys to which a passenger ship must be subjected
- describes the extent of the surveys of passenger ships
- describes the requirements for surveys of life-saving appliances and other equipment of cargo ships, including mandatory annual surveys
- describes the requirements for surveys of radio and radar installations of cargo ships
- describes the requirements for surveys of hull, and their extent, machinery and equipment of cargo ships, including mandatory annual surveys
- describes the extent of the surveys of hull, machinery and other equipment of cargo ships
- states that the condition of the ship and its equipment must be maintained to conform with the provisions of the regulations
- states that after any survey of a ship required by SOLAS, no change should be made in the structural arrangements, machinery, equipment or other items covered by the survey without the sanction of the Administration
- states that any accident to a ship or defect affecting the safety of the ship or the efficiency or completeness of the life-saving appliances or equipment should be reported to the Administration or organization responsible for issuing the relevant certificate, who will decide whether a survey is required
- lists the surveys and their extent to which a passenger ship must be subjected
- states that an accident or defect should also be immediately reported, by the master or owner, to the appropriate authorities of the port State when the ship is in a port of another Party to the SOLAS Convention
- lists the certificates, including attachments and supplements, where appropriate, issued after survey to ships satisfying the requirements of SOLAS
- states the period of validity of each of the certificates
- states that no Exemption Certificate is not valid for longer than the period of validity of the certificate to which it refers
- states that no extension of the five-year period of validity of the Cargo Ship Safety Construction Certificate is permitted
- explains the circumstances under which other certificates may be extended and states the maximum extension permitted

- describes the circumstances in which certificates cease to be valid
- states that all certificates or certified copies of them should be posted up in a prominent and accessible place in the ship
- states that certificates issued under the authority of a contracting Government should be accepted by other contracting Governments
- states that a ship in the port of another Party is subject to control by officers authorized by that Government so far as verifying that the SOLAS Convention certificates are valid
- describes the procedures which may be followed by officers authorized by a port State in exercising control regarding SOLAS Convention Certificates or Load Line Convention Certificates
- states that the surveyor should also take into account the requirements of SOLAS reg. V/13 that all ships should be sufficiently and efficiently manned
- states that, at the conclusion of a control exercise the master should be provided with a document giving the results of the control exercise and details of any action taken
- states that Parties to the Protocol of 1978 to the SOLAS Convention, 1974, should apply the requirements of the Convention and Protocol as may be necessary to ensure that no more favourable treatment is given to ships of non-parties to the Convention and Protocol

**SOLAS —Subdivision and Stability, Machinery and Electrical Installation R2
(2 hours)**

- defines, with reference to chapter II—1:
 - subdivision load line
 - deepest subdivision load line
 - length
 - breadth
 - draught
 - bulkhead deck
 - margin line
 - permeability of a space
 - machinery space
 - passenger spaces
 - watertight
- explains what is meant by 'floodable length'
- explains what is meant by 'factor of subdivision'
- explains the application of the factor of subdivision to a passenger ship's ability to withstand the flooding of adjacent main compartments
- describes the requirements regarding unsymmetrical flooding
- states that the master should be supplied with suitable information concerning the use of cross—flooding fittings
- describes the final conditions of the ship after assumed critical damage
- states that the master should be supplied with the data necessary to maintain sufficient intact stability under service conditions to enable the ship to withstand the critical damage
- states that the conditions of stability on which the calculations of heel are based should be supplied to the master of the ship
- states that excessive heeling might result should the ship sustain damage when in a less favourable condition
- states that water ballast should not in general be carried in tanks intended for oil fuel and describes the arrangement for ships which cannot avoid putting water in oil fuel tanks

- describes the marking of subdivision load lines on passenger ships
- states that details of the subdivision load lines assigned and the conditions of service for which they are approved should be clearly indicated on the Passenger Ship Safety Certificate
- states that a ship should not be loaded so as to submerge the load line mark appropriate to the season and locality, as determined in accordance with the international Convention on Load Lines, whatever the position of the subdivision load line marks may be
- states that a ship should not be loaded so as to submerge the subdivision load line mark appropriate to the particular voyage and condition of service
- classifies watertight doors as:
 - class 1 — hinged doors
 - class 2 — hand—operated sliding doors
 - class 3 — sliding doors which are power—operated as well as hand—operated
- describes the provisions regarding the fitting of watertight doors in passenger ships
- states that watertight doors in bulkheads dividing cargo between deck spaces must be closed before the voyage commences and must be kept closed during navigation
- states that the time of opening between—deck doors in port and the time of closing them before leaving port should be entered in the log—book
- states that all watertight doors should be kept closed during navigation except when necessarily opened for the working of the ship, in which, case they should always be ready to be immediately closed
- states that in passenger ships carrying goods vehicles and accompanying personnel indicators are required on the navigating bridge to show automatically when each door between cargo spaces is closed and all door fastenings are secured
- states that sidescuttles the sills of which are below the margin line, should be of such construction as will effectively prevent any person opening them without the consent of the master
- states that certain sidescuttles in between—deck spaces must be closed watertight and locked before the ship leaves port and must not be opened before arrival at the next port
- describes the requirements for deadlights
- states that sidescuttles and deadlights which will not be accessible during navigation must be closed and secured before the ship leaves port
- states that the closing and locking of sidescuttles and deadlights in spaces used alternatively for the carriage of passengers or cargo should be recorded in a log—book when carrying cargo
- states the requirements for the closure of cargo loading doors in passenger ships
- describes the requirements for drills, operation and inspection of watertight doors and other openings in passenger ships
- states that valves, doors and mechanisms should be suitably marked to ensure that they may be properly used to provide maximum safety
- lists the entries which should be made in the log—book regarding the opening and closing of doors, sidescuttles and other openings and the drills and inspections required by the regulations
- states that every passenger ship and every cargo ship of 24 metres and upwards must be inclined upon its completion and the elements of its stability determined
- states that the master should be supplied with such information as is necessary to obtain accurate guidance as to the stability of the ship under varying conditions of service
- describes the contents of damage control plans for passenger ships
- states that booklets containing the damage control information should be made available to the ship's officers

- describes the recommendations on damage control for dry cargo ships
- describes the indicator system which must be provided on the navigating bridge of passenger ro-ro ships to show if shell doors, loading doors and other closing appliances are not fully closed or not secured
- states the requirements for the detection of water leakage through shell doors or vehicle loading doors which could lead to major flooding of special category spaces or ro-ro cargo spaces
- states the requirements for ro-ro cargo spaces to be monitored whilst the ship is under way

**SOLAS –Fire Protection, Fire Detection and Fire Extinction
(2 hours)**

R2

- outlines the basic principles of the regulations on fire protection
- explains briefly the properties of class 'A' and class 'B' divisions
- defines:
 - main vertical zones
 - accommodation spaces
 - public spaces
 - service spaces
 - cargo spaces
 - ro-ro cargo spaces, open and closed
 - special category spaces
 - machinery spaces of category A
 - control stations
- states that fire hoses should be used only for the purposes of extinguishing fires or testing the apparatus at fire drills and surveys
- describes the information included in fire control plans or booklets
- states that instructions concerning the maintenance and operation of all fire-fighting equipment and installations on board should be kept under one cover in an accessible position
- states that a duplicate set of fire control plans or booklet should be permanently stored in a prominently marked weathertight enclosure outside the deckhouse for the assistance of shoreside fire-fighting personnel
- states that all fire-extinguishing appliances must be kept in good order and available for immediate use at all times during the voyage
- states that passenger ships must at all times when at sea, or in port, be so manned or equipped that any initial fire alarm is immediately received by a responsible member of the crew
- states that a special alarm, operated from the navigating bridge or from the fire control station, should be fitted to summon the crew and should be capable of being sounded independently of the alarm to the passenger spaces
- states that an efficient patrol system must be maintained for ships carrying more than 36 passengers
- describes the training required by the fire patrol
- states that there are special requirements for ships carrying dangerous goods
- states that a ship should have a document provided by the Administration as evidence of compliance of construction and equipment with the requirements for the carriage of dangerous goods

SOLAS –Life-Saving Appliances and Arrangements (2 hours)

R2, R28

- defines with reference to chapter III of SOLAS
 - certificated person

- float—free launching
- inflatable appliance
- inflated appliance
- launching appliance or arrangement
- rescue boat
- survival craft
- states that life—saving appliances and arrangements required by chapter III of SOLAS must be approved by the Administration
- states the requirements for exhibiting muster lists
- describes the illustrations and instructions to be displayed in passenger cabins and other spaces **R2, R13**
- lists the items to be included in muster lists and emergency instructions
- describes the provision of operating instructions for life—saving appliances
- explains how the crew should be assigned to survival craft to ensure satisfactory manning and supervision of survival craft
- states that the person in charge of a survival craft should have a list of its crew and should see that they are acquainted with their duties
- states the requirement, for the provision of training manuals
- lists the items which should be contained in the training manuals
- describes the frequency of abandon ship drills and fire drills and how they should be conducted
- describes the guidelines for training crews for the purpose of launching lifeboats and rescue boats from ships making headway through the water **R14**
- describes the on—board training which should be given in the use of life—saving appliances and in survival at sea
- details the records which should be made of abandon ship drills and fire drills, other drills of life—saving appliances and on—board training
- states that before leaving port and at all times during the voyage, all life—saving appliances must be in working order and ready for immediate use
- describes the instructions for on—board maintenance of life—saving appliances which should be carried
- describes the regulation regarding the maintenance of falls
- describes the weekly and monthly tests and inspections required and the entries which should be made in the log—book
- describes the requirements regarding the periodic servicing of inflatable liferafts, inflatable lifejackets, inflated rescue boats and hydrostatic release gear
- describes the requirements for passenger muster stations
- states that, on passenger ships, an abandon ship drill and a fire drill must take place weekly

SOLAS—Radiocommunications(amended chapter IV)(2 hours)

R2

- states that the 1988 amendments to the 1974 SOLAS Convention replace the existing Chapter IV with a new Chapter IV covering the global maritime distress and safety system (GMDSS)
- states that the amended Chapter IV applies to passenger ships, irrespective of size, and cargo ships of 300 tons gross tonnage and upwards engaged on international voyages
- states that every ship must comply with the regulations concerning NAVTEX and satellite EPIRB
- states that every ship constructed on or after 1 February 1995 must comply with all applicable requirements
- explains the applicability to ships built before 1 February 1995
- explains the meanings, for the purpose of the amended Chapter IV, of:

- bridge-to-bridge communications
- continuous watch
- digital selective calling (DSC)
- direct—printing telegraphy
- general radiocommunications
- international NAVTEX service
- locating
- maritime safety information
- polar orbiting satellite service
- sea area A1
- sea area A2
- sea area A3
- sea area A4
- states that every ship, while at sea, must be capable of:
 - transmitting ship—to—shore distress alerts by at least two separate and independent means
 - receiving shore—to—ship distress alerts
 - transmitting and receiving ship to—ship distress alerts
 - transmitting and receiving search and rescue co—ordinating communications
 - transmitting and receiving on—scene communications
 - transmitting and receiving signals for locating
 - transmitting and receiving maritime safety information
 - transmitting and receiving general radio—communications
 - transmitting and receiving bridge—to—bridge communications
- lists the radio equipment to be carried by all ships
- describes the requirements regarding the installation and operation of the satellite EPIRB
- lists the additional equipment required by ships engaged on voyages exclusively within sea area A 1
- lists the additional equipment required by ships engaged on voyages within sea areas A 1 and A2
- lists the additional equipment required by ships engaged on voyages within sea areas A1, A2 and A3
- states that equipment using the inmarsat geostationary satellite service is not an acceptable alternative for ships engaged on voyages which include sea area A4
- states the requirements for maintaining watch on distress frequencies
- states that every ship, while at sea, must maintain a watch for broadcasts of maritime safety information
- describes how the availability of radio equipment required by the regulations is to be ensured
- states that every ship must carry personnel qualified for distress and safety radiocommunications purposes who hold certificates specified in the Radio Regulations
- states that one person is designated to have primary responsibility for radiocommunications during distress incidents
- states that a record must be kept of all incidents connected with the radiocommunication service which appear to be of importance to the safety of life at sea

SOLAS –Carriage of Grain (1 hour)

R2, Ch. VI

- lists the intact stability requirements for a ship carrying bulk grain **Part C**
- lists the contents of the grain loading information referred to in the document of authorization

SOLAS –Carriage of Dangerous Goods (1 hour)

R2

- states that the regulations concerning the carriage of dangerous goods in packaged form or in solid bulk form apply to all ships to which the SOLAS regulations apply and to cargo ships of less than 500 gross tons
- states that the provisions do not apply to ships' stores and equipment
- states that the carriage of dangerous goods is prohibited except in accordance with the provisions of the regulations
- states that the provisions should be supplemented by detailed instructions on safe packaging and stowage, which should include the precautions necessary in relations to other cargo, issued by each Contracting Government **R15, R16**
- classifies dangerous goods according to the IMDG Code
- states that the correct technical name of goods, and not trade names, should be used in all documents relating to the carriage of dangerous goods
- states that the documents prepared by the shipper should include or be accompanied by a signed certificate or declaration that the shipment offered for carriage is properly packaged and marked and in proper condition for carriage
- states the requirements for a special list or manifest of dangerous goods on board and their location or a detailed stowage plan showing the same information
- outlines the stowage requirements for dangerous goods
- states that substances which are liable to spontaneous heating or combustion should not be carried unless adequate precautions have been taken to minimize the likelihood of the outbreak of fire
- lists the explosives which may be carried in a passenger ship
 - defines:
 - International Bulk Chemical Code (IBC Code)
 - chemical tanker
- states that the regulations apply to chemical tankers constructed on or after 1 July 1986, including those of less than 500 gross tons
- states that a chemical tanker must comply with the survey requirements for a cargo ship and, in addition, be surveyed and certified as provided for in the IBC Code
- states that the IBC Code prescribes the design and construction standards of such ships, the equipment they should carry and marine pollution aspects **R17**
- states that the requirements of the IBC Code are mandatory and subject to port State control
- defines: **R18**
 - International Gas Carrier Code (IGC Code)
 - gas carrier

The International Safety Management (ISM) Code

R29

- states that a Safety Management System in compliance with the ISM Code must be in place on board all vessels of 500 gross tonnage and upwards
- states that the details of the ship's system may be found in the ship's Safety Management Manual

International Convention on Standards of Training, Certification and Watchkeeping for Seafarers, 2010 (STCW) (2 hours)

R1

- explains the general obligations under the Convention
- defines, for the purpose of the Convention:
 - Certificate of Competency
 - Certificate of Proficiency
 - Certificated
 - Seagoing ship
 - Radio Regulations
- explains the application of the Convention
- describes the issue of certificates and their endorsement by the issuing Administration
- describes the conditions under which dispensations may be granted
- states that ships, when in a port of a party to the Convention, are subject to control to verify that all seafarers serving on board who are required to be certificated are so certificated or hold a valid dispensation
- states that a ship which extends its voyage beyond what is defined as a near—coastal voyage by a Party must fulfil the requirements of the Convention without the relaxation allowed for near—coastal voyages
- describes the control which may be exercised by a duly authorized control officer
- describes the circumstances in which the control officer should supply written information to the master regarding deficiencies and the grounds under which the ship may be detained
- explains that the regulations contain:
 - mandatory minimum requirements for the certification of masters, officers, able seafarers deck or engine and ratings forming part of a navigational watch or an engineering watch
 - mandatory minimum requirements for the training and qualifications of masters, officers and ratings of oil, chemical and gas tankers
 - mandatory minimum requirements to ensure the continued proficiency and updating of masters, officers, able seafarers, deck or engine and ratings forming part of a navigational watch or an engineering watch
 - basic principles to be observed in keeping navigational and engineering watches
 - mandatory minimum requirements for the issue of a Certificate of Proficiency in Survival Craft and Rescue Boats other than Fast Rescue Boats

ITU Radio Regulations (2 hours)

- states that the International Telecommunication Union (ITU) is the UN specialized agency responsible for regulations governing the use of the radio spectrum
- states that the provisions concerning certificates for personnel of ship stations and ship earth stations with personnel of stations in the maritime mobile and maritime mobile—satellite service are set out in articles 55 and 56 respectively, of the Radio Regulations
- states that articles 55 and 56 of the Radio Regulations also provide for the issue and use of GMDSS certificates as follows:
 - first—class radio electronic certificate
 - second—class radio electronic certificate
 - general operator's certificate
 - restricted operator's certificate
- states that the conditions of issue, the knowledge and the experience required for each GMDSS certificate are set forth in article 55 of the Radio Regulations

- states that article 56 of the Radio regulations stipulates the class and minimum number of operators or personnel for ship stations and ship earth stations
- states that the provision of the Radio Regulations as amended and the provisions of the revised chapter IV of the SOLAS Convention differ with respect to maintenance requirements and requirements for carriage of personnel
- states that a number of members of the ITU made a declaration regarding the revised articles 55 and 56 of the Radio Regulations which thereby do not apply to them
- states that, although they differ, the ITU and IMO requirements are held to be compatible

**Special Trade Passenger Ships Agreement, 1971, and Rules, 1971(STP 1971)
(1 hour)**

R19

- describes the application of the agreement
- defines, for the purpose of the rules:
 - Convention
 - special trades
 - weather deck
 - upper deck
 - special trade passenger
 - special trade passenger ship
- explains the issue of certificates
- states that certificates or certified copies issued under this agreement should be posted in a prominent and accessible place in the ship
- explains the qualification of certificates when the number on board is less than stated in the Special Trade Passenger Ship Safety Certificate
- describes the rule regarding the carriage of dangerous goods in special trade passenger ships
- states that ships to which the Agreement applies should comply with the International Health Regulations, having regard to the circumstances and nature of the voyage

R20

**Protocol and Rules on Space Requirements for Special Trade Passenger Ships,
1973 (SPACE STP 1973) (1 hour)**

R21

- describes the application of the Protocol
- states that a certificate called a Special Trade Passenger Ship Space Certificate is to be issued after inspection and survey of a special trade passenger ship which complies with the applicable requirements of these rules
- states that the Certificate or a certified copy of it should be posted up in a prominent and accessible place in the ship
- lists the spaces not suitable for the carriage of passengers
- states that spaces, including airing spaces, allotted for the accommodation or use of special trade passengers must be kept free of cargo
- states that ships to which the rules apply should comply with the International Health Regulations, having regard to the circumstances and nature of the voyage
- explains that the 1974 SOLAS Convention provides that special trade passenger ships may be exempted from full compliance with the requirements of chapters II–1, II–2 and III, provided they fully comply with the provisions of the Rules annexed to the Special Trade Passenger Ships Agreement, 1971, and to the Protocol on Space Requirements for Special Trade Passenger Ships, 1973

Athens Convention relating to the Carriage of Passengers and their Luggage by Sea (PAL 1974) (1 hour)

R22

- defines, for the purposes to the Convention:
 - carrier
 - performing carrier
 - ship
 - passenger
 - luggage
 - cabin luggage
 - carriage
 - international carriage
- explains the application of the Convention
- describes when the carrier is liable for the damage suffered as a result of the death of or personal injury to a passenger and the loss of or damage to luggage
- describes the presumption of fault or neglect of the carrier, unless the contrary is proved
- explains the carrier's liability in respect of monies and valuables
- states that, in the case of contributory fault on the part of the passenger, the court hearing the case may exonerate the carrier wholly or partly from his liability
- states that limits of liability for personal injury and for loss of or damage to luggage are prescribed
- describes that if an action is brought against a servant or agent of the carrier arising out of damage covered by this Convention, such servant or agent, if he proves that he acted within the scope of his employment, will be entitled to the same defences and limits of liability as the carrier
- states that where entitlement to limit liability exists, the aggregate of the amounts recoverable from the carrier, or performing carrier, and a servant or agent must not exceed the prescribed limit of liability
- describes the circumstances in which the right to limit liability will be lost
- explains where an action arising under this Convention maybe brought
- describes the invalidity of contractual provisions more favourable to the carrier than the provisions of this Convention

International Convention on Tonnage Measurement of Ships, 1969

R22

- defines, for the purposes of the Convention:
 - international voyage
 - gross tonnage
 - net tonnage
 - new ship
 - existing ship
- explains the applications of the Convention to new and existing ships
- states that an International Tonnage Certificate (1969) will be issued to every ship, the gross and net tonnages of which have been determined in accordance with the Convention
- explains the alterations in construction or use of spaces which would lead to the cancellations of the International Tonnage Certificate
- states that a ship flying the flag of a State the Government of which is a Contracting Government is subject to inspection, when in the ports of other Contracting Governments, for the purpose of verifying that the ship is provided with a valid International Tonnage Certificate and that the main characteristics of the ship correspond to the data given in the certificate

- states that certain ships, required to be measured under the 1969 Tonnage Convention, may be allowed by their Administrations to use the gross tonnage as measured by the national tonnage rules in effect prior to the coming into force of the Tonnage Convention, for the application of certain provisions of the SOLAS, MARPOL and STCW Conventions
- states that the tonnage as measured by the national rules appears only on the relevant certificates required by SOLAS and MARPOL, together with an explanatory note

International Convention for the Control and Management of Ship's Ballast Water and Sediments, 2004

- defines the following:
 - ballast water
 - ballast water management
 - sediments
- describes the conditions where the application of this convention may be exempted
- describes the application of this convention
- describes the management and control requirement based on Section B Regulation B1 to B6
- describes the standards that need to be observed in ballast water exchange

COMPETENCE 4.7	Application of leadership and team working skills	IMO Reference
----------------	---------------------------------------------------	---------------

TRAINING OUTCOMES:

Demonstrates a knowledge and understanding of:

4.7.1 APPLICATION OF LEADERSHIP AND TEAMWORKING SKILLS

4.7.1 APPLICATION OF LEADERSHIP AND TEAMWORKING SKILLS

Textbooks: T74

Teaching aids:

Required performance:

1.1 Introduction to Management (2 hour)

- defines the term "Management"
- describes the following management activities:
 - Planning
 - Organizing and Staffing
 - Directing
 - Controlling
- describes the roles of company's objectives and goals
- describes the management policy with respect to ships
- describes managerial issues on:—
 - Operations;
 - Finance;
 - Communications.
- describes the company's expectations for ship's officers.

1.2 Related Conventions and National Legislations (2 hours)

- Explains objectives and aims of the Maritime Labour Convention, 2006 (MLC)
- Describes outlines of the relevant provisions in the MLC concerning conditions of employment, and compliance and enforcement
- Describes the relevant provisions in the STCW Convention and Code concerning responsibilities of seafarers and shipping industries, and fitness for duties for working on shipboard tasks
- Explains what national legislations concerned they have and how the legislations are implemented, referring to relevant regulations/recommendations

1.3 Applies Task and Workload Management (4 hours)

- describes the following types of planning:
 - Long—range planning
 - Intermediate planning
 - Short—range planning
- explains the importance of planning and use of resources for executing a job
- describes the following activities in the planning process:
 - Official goals
 - Development of plans
 - Preparation of detailed plans
 - Preparation of budgets
- describes the following essential steps to make planning effective:
 - Using established techniques
 - Participative planning
 - Communication with subordinates
 - Simplicity of plans
 - Flexibility of plans
 - Monitoring of implemented activities

- describes the following barriers to planning:
 - Environment of the organization
 - Reluctance to establish goals
 - Inadequate reward system
 - Resistance to change
 - Time and expense
- describes the following techniques that can be used to overcome the barriers to a planning process:
 - Support from upper management
 - Communication to all
 - Participation of all members
 - Review and updates of plans
 - Sharing of information
- describes the following:
 - Decision making under certainty
 - Decision making under risk
 - Decision making under uncertainty
- describes the following basic elements of organizational structure:
 - Work specialization based
 - Departmentation
 - Pattern of authority
 - Span of control
 - Coordination of activities
- describes the following three sets of employee behaviours:
 - Participation
 - Effort
 - Performance
- describes the typical traits of the following personality types:
 - Risk takers
 - Authoritarian
 - Dogmatic
 - Focus of control
 - Tolerant of ambiguity
 - Machiavellianism
 - Self–Monitoring
- describes motivation and explains why is it important in an organization
- defines "goal" and explains the functions of goals
- describes the role of the following attributes of goals, in success achieving goals:
 - Specificness of goals
 - Goal difficulty
 - Goal acceptance

1.4 Applies Effective Resource Management and Decision Making (4 hours)

- defines "communication"
- describes the importance of the following functions of the communication process:
 - Information
 - Motivation
 - Control
 - Emotion

- describes the process of communication with regards to the following:
 - Encoder
 - Transmitter
 - Receiver
 - Decoder
- describes the following common causes of failure of communication:
 - Noise
 - Distraction
 - Misrepresentation
 - Information retention
 - Stereotyping the sender
- demonstrates the ability to "effectively communicate" (Oral, Written & Non–Verbal) with others
- interprets and carry out verbal instructions
- describes the following types of leaders:
 - Transactional leaders
 - Transformational leaders
 - Democratic leaders
 - Autocratic leaders
- explains the following types of leader ship behaviours:
 - Directive leadership
 - Supportive leadership
 - Participative leadership
 - Achievement–oriented leadership
- describes the following factors that influence the way the leaders' behaviour affects subordinates' response:
 - Job pressure
 - Job satisfaction
 - Subordinates' need for information
 - Subordinates' expectations
- describes the following stages of a group development:
 - Membership
 - Sub–grouping
 - Confrontation
 - Individual differentiation
 - Collaboration
- describes and elaborates on the process of group meeting management, with regards to the following:
 - Defining the group assignment
 - Planning the group effort
 - Organizing and staffing the committee
 - Direct and control the committee
- describes the following sources of organizational conflict:
 - Task interdependence
 - Goal incompatibility
 - Shared resources
 - Departmental differences
 - Uncertainty
 - Reward system

- describes the following techniques for preventing group conflicts:
 - Organization goals over unit goals
 - Predictable and stable task structure
 - Efficient interdepartmental communication
 - Avoid "win—lose" situations
- describes how some of the following techniques may be ineffective in managing group conflicts:
 - No action
 - Delayed action
 - Secrecy
- describes the use of stringent rules and regulations to resolve conflicts
- describes the process and importance of control systems to an organization
- describes the following activities in the control process:
 - Monitoring the environment
 - Determining direction
 - Assessing ongoing operations
 - Assessing the control system
- describes the following five stages of problem solving:
 - Define the problem
 - Generate alternatives
 - Evaluate and choose
 - Implement decision
 - Control decision
- describes the methods of identify and consider generated option
- describes the difference between formal and personal authority and discuss how/when to best exercise each type
- compares and contrasts between "Large" and "Small" power distance culture within different nationalities
- describes the importance of pre—planning whenever carrying out major and/or critical jobs
- describes the importance of carryout situation and risk assessment before commencing major operation
- describes the concept of delegation and it's benefits
- describes & analyses some important factors that may affect group behaviour, discipline and the amount of work done by the crew
- describes an efficient method of establishing an open communication style on board that encourages challenges and appropriate responses from the team
- describes the need for evaluation of outcomes effectiveness

COMPETENCE 4.8 Contribute to the safety of personnel and ship IMO Reference

TRAINING OUTCOMES:

Demonstrates a knowledge and understanding of:

STCW Code
Section A-VI/1 para 2

4.8.1 KNOWLEDGE OF PERSONNEL SURVIVAL TECHNIQUES

See IMO Model Course 1.19, and the requirements of STCW Code Table A-VI/1-1 for Competence in personal survival techniques

STCW Code
Table A-VI/1-1

4.8.2 KNOWLEDGE OF THE FIRE PREVENTION AND ABILITY TO FIGHT AND DISTINGUISHING FIRES

See IMO Model Course 1.20, and the requirements of STCW Code Table A-VI/1-2 for Competence in fire prevention and fire fighting

STCW Code
Table A-VI/1-2

4.8.3 KNOWLEDGE OF ELEMENTARY FIRST AID

See IMO Model Course 1.13, and the requirements of STCW Code Table A-VI/1-3 for Competence in elementary first aid

STCW Code
Table A-VI/1-3

4.8.4 KNOWLEDGE OF PERSONAL SAFETY AND SOCIAL RESPONSIBILITIES

See IMO Model Course 1.21, and the requirements of STCW Code Table A-VI/1-4 for Competence in personal safety and social responsibility

STCW Code
Table A-VI/1-4

APPENDICES

MARINE ENGINEERING AT THE OPERATIONAL LEVEL

■ Purpose

This syllabus covers the knowledge of basic engineering science which is deemed to provide the depth of knowledge required by the Standards of Competence in Table A-III/1 of Section A-III/1 of the STCW 2010 Code for a candidate for certification as officer in charge of an engineering watch.

It is recommended that the appended subjects area be considered as providing pre-requisite level of knowledge required before attempting the main functional competencies.

■ Training objectives

This function provides the background knowledge to support:

An understanding of the physical principles underlying the behaviour of the ship and its environment and the functioning of equipment upon which to build professional studies. Trainees will also be better able to understand technical specifications and instructions regarding equipment with which they are not familiar.

■ Entry standards

Trainees should be proficient in calculations involving the basic arithmetical operations of addition, subtraction, multiplication and division, including the use of fractions and decimal fractions. They should also have some knowledge of elementary algebra and be capable of solving problems leading to simple equations, including transposition of equations, if necessary.

Some previous study of a science subject, involving experimental work and the making, recording and processing of measurements, would be an advantage. It is worth mentioning Maths, Physics and Chemistry at High School level.

■ Teaching facilities and equipment

In addition to ordinary classroom facilities, which may be used for the teaching of theory, a laboratory suitably equipped with work benches and apparatus for practical work and demonstrations will be required.

■ Guidance notes

These notes are included to provide additional information where appropriate.

Appendix 1 – Basic Engineering Science

The subject has been presented in this manner in an effort to introduce engineering principles for all training outcomes in order that trainees will, from the beginning, know the relationship between quantities when they are later taught separately about:

- thermodynamics
- mechanical science, and
- marine electrotechnology

These basics should, as recommended, be a pre-requisite to the main programme and should ideally be completed before the three engineering science subjects are commenced.

The guidance which follows refers to specific topics.

The term "specific gravity" is still in widespread use and attention should be drawn to this when covering training outcome 1.1, Mass and volume.

Measuring density and temperature is intended to give trainees an opportunity to recognize and use simple instruments.

It is very important that trainees learn the meaning of velocity and acceleration and the units.

The use of graphs in training outcome 1.2, Dynamics is introduced for the first time in this subject; they should be simple, showing constant speed, instant change of speed and uniform, change of speed. Trainees must learn the difference between weight and mass and they must also be made aware of the misconceptions common in daily life.

The treatment of friction is intended to be simple but should include recognition of the fact that resistance occurs when bodies move on rough and on smooth surfaces, in air and in liquids.

When covering training outcome 1.3, Energy Work and Power, petroleum fuel oils should be used as examples of fuels and others could be mentioned.

The treatment of inertia should be simple and not include difficult calculations.

The area under a force–distance graph, representing work done, will often occur in later studies and should be treated with relevant importance.

Care should be taken to ensure that trainees understand the difference between work and power.

Trainees should be made aware that numerous ways are used to express pressure; however, they should use S.I. units.

Opportunity should be taken to show how very high forces occur when moderate pressures are applied to large surface areas.

A simple treatment of calorific values is required at this stage of training and realistic marine fuel values should be used.

Various marine examples of expansion and contraction should be used, such as expansion of pipes (including compensation bends etc.), shrinking metal by cooling or heating to obtain built–up construction such as crankshafts, rudder stocks, etc.

Appendix 2 – Mathematics

Trainees will probably enter the course already in possession of some mathematical ability. This being so, it would be advisable to give a simple test to establish their level of understanding.

There is a possibility that some revision will be necessary for trainees to meet the training outcomes, even if they have covered the work elsewhere.

Trainees need to be able to handle indices in their work on thermodynamics.

Although trainees may not require to use logarithms in their duties, it is considered that such knowledge is of fundamental importance. The evaluation of numbers raised to powers will be necessary in other subjects. Trainees are likely to encounter graphs with logarithmic scales later in their experience.

It is very important that the symbols for S.I. units are understood and used throughout. The prefixes for multiples of ten are in widespread use in marine work.

Trainees should be capable of evaluating expressions by using both a calculator and logarithms, as well as by basic arithmetic where applicable.

Trainees will have to perform algebraic processes in many applications. The examples used in training outcome 1.5 are typical.

It is quite adequate to be able to solve quadratic equations by one method.

Training outcomes in 1.6 are all used in the subject 'electro technology' in the chief and second engineer's course (IMO Model Course 7.02).

A marine engineer frequently has to interpret graphs and occasionally has to plot them; hence training outcome 1.8.

Trainees do not have to carry out differentiation or integration; nevertheless, some insight into these concepts and their application would be of value.

Rates of change are of importance in control engineering; often the expression dy/dx occurs, particularly in technical journals, and trainees therefore need to be familiar with its meaning.

Appendix 3 – Thermodynamics

The terminology and concepts required in this subject are introduced in a simple manner in Appendix 1, Basic Engineering Science.

In some cases the book references develop the theory to a stage beyond that required for the watchkeeping certificate. Care must therefore be taken to ensure that trainees reach the level defined by the specific training outcome. Teaching beyond that level should only take place in rare instances, when it is absolutely necessary in order to give a clear understanding of the specific training outcome. The trainee should not be expected to achieve a level higher than that specified. For this reason the instructor is advised to prepare notes which give clear indication to the trainees of the work they need to do.

Training outcomes are intended to serve as reinforcement of earlier work. Pressure-measuring devices should already have been covered and should not have to be repeated.

Internal and Intrinsic energy have reference to chapter 1.6 of the textbook (T25). It is questionable whether the descriptions of the early misconceptions should be used. Trainees may be in danger of becoming confused and remembering the wrong things.

Trainees will learn the difference between a non-flow system and a steady-flow system; the latter will be introduced when studying for more advanced certificates.

Energy change is included in order to provide a basis for **Vapours**.

The problems in training objectives referring to heat transfer should be simple, such as to find the final temperature of a mixture of liquids or of a solid placed in a liquid when all other required information is known. Heat losses can be mentioned but their inclusion in problems may cause confusion. Similarly, water equivalents can be introduced but should not be over-emphasized. Laboratory work can be introduced provided heat losses can be minimized.

Marine engineers are concerned with a number of vapours; however, steam and the refrigerants are the only vapours commonly used in cyclic processes. Although the references in the textbook are concerned mainly with steam, opportunity should be taken to introduce work involving the use of thermodynamic properties of refrigerants, using the appropriate tables.

A throttling calorimeter can be used to good effect providing the results obtained can be realistic.

In place of "perfect gas", as for all practical purposes the behaviour of a gas deviates slightly, the term "ideal" is used. As far as practising marine engineers are concerned, the difference is of little importance. Problems should be concerned with practical compression and expansion in diesel engines and compressors.

Thermodynamic processes, the versatility of the equation $PV^n = C$ should be emphasized. Description should be given of processes which are nearly adiabatic and in practice are usually taken to be so. The second law of thermodynamics is introduced and should be related to practical applications. To handle problems concerned with polytrophic processes, trainees require to calculate values of, say, $5^{1.3}$. This is covered in **Mathematics**, but may require some revision. Such evaluation could be by use of a suitable electronic calculator. It is important that the evaluation is not allowed to obscure the principles being learnt.

It is recommended that any calculations used to ascertain values of n are kept simple and practical.

Appendix 4 – Mechanical Science

The term "couple" is frequently used in technical papers, and trainees should therefore become familiar with its meaning.

Relative velocity should include that of two objects on converging and diverging paths.

It is intended that retardation, i.e. negative acceleration, should be included.

It is not intended to include friction on the inclined plane.

The principle of the pressure created by a head of liquid in a vertical pipe is very important to a marine engineer and should be illustrated by the use of realistic problems. This can also be demonstrated if the appropriate apparatus is available.

Energy changes in a moving liquid can be demonstrated if the equipment is available. It is also possible that the training outcome can be verified experimentally, using the same apparatus. It is not intended that the coefficient of discharge should be used in calculations at this stage.

Appendix 5 – Industrial Chemistry

It is not intended that trainees should learn to handle chemical equations, and the objectives clearly indicate this. If, however, trainees enter the course already with a sound background in chemistry, the instructor may find it more acceptable to use equations and other more advanced processes to arrive at the same objectives. The important issue is to ensure that trainees achieve the standard laid down. Later, when studying for more advanced certificates, each topic is taken further, but even then the chemistry is not taken to any greater theoretical depth.

"Fundamentals", includes amongst its training outcomes, a series of definitions; as these are not covered in the recommended textbook, suggested definitions are given in the guidance notes. If definitions are to be used from other sources, care should be taken to ensure that they are not so comprehensive as to obscure the purpose described above.

In many cases training outcomes may be best achieved by trainees performing experiments and tasks; the time suggested allows for this.

Simple definitions are adequate; examples are given below:

An atom is the smallest particle of an element which can take part in a chemical reaction.

A molecule is the smallest particle of a substance capable of independent existence while still retaining its chemical properties: it consists of more than one atom.

Chemical element: a substance which cannot be decomposed by chemical means— there are 92 stable elements.

Chemical compound: a substance composed of two or more elements in definite proportions by mass.

Chemical reaction: a process in which a substance is changed into another—involves rearrangement of molecular structure.

Trainees will see chemical symbols and equations in books, technical papers, or on instrument display faces etc., and familiarity with them will therefore be an advantage. However, a seagoing marine engineer does not normally have to use symbols and equations except possibly as shorthand in reports.

Solution: a mixture (of variable composition) of two or more substances, one of which is usually a liquid.

Solubility: the ability of a substance to dissolve in a solvent.

Saturated solution: a solution which can exist in equilibrium with excess of the dissolved substance.

Suspension: a fluid in which denser particles cannot settle out and are distributed throughout. Opportunity should be taken to demonstrate these conditions by adding, say, sodium

chloride to a beaker of fresh water and measuring its density at various stages until no more can be dissolved.

In later work, when preparing for a higher qualification, trainees will cover the determination of alkalinity of boiler feedwater by more accurate methods.

Samples of common metals with passive oxide films should be shown. Seawater as an electrolyte can be easily demonstrated by setting up a cell, using seawater as the electrolyte, and a galvanometer.

If available, show pictures or samples of metals affected by graphitization and dezincification.

Opportunity can be taken to measure the density of salts in solution to demonstrate metallic salts.

It is sufficient for a marine engineer to consider the carbon content of each fuel stated to be reasonably constant. The increase in sulphur content is of particular importance as fuel become "heavier". The same applies to the ash and water contents, which are zero or negligible for petrol and kerosene; both ash and water are usually present, sometimes in disturbing quantities, in "heavy" fuels.

Introduction to fuels and lubricants should include precautions with pipework, storage, venting, heating, protection against opening pressurized filters, sources of ignition, discharge from relief valves, operation of sludge valves, drip trays, cofferdams and pipe shrouding.

If laboratory equipment and time are available, trainees would benefit from at least witnessing the tests specified in training outcomes. In any case, trainees should be made familiar with the crude tests which can be performed on board ship.

Teaching aids (A)

A classroom equipped with a black/white board and an overhead projector is required for the theory of the course.

A1 Instructor Guidance.

Textbooks (T)

There are many textbooks which cover mathematics at the level of this syllabus. The choice of textbook is left to the discretion of the instructor

- T13 Hannah—Hillier, J. Applied Mechanics. Harlow, Longman 1995. (ISBN 0582 25632.1)
- T24 Jackson, L and Morton, T.D. General Engineering Knowledge for Marine Engineers. 5th ed. London, Thomas Reed Publications Ltd 1990. (ISBN 0947 637.761)
- T25 Joel, R. Basic Engineering Thermodynamics In SI Units. 4th ed. Harlow, Longman, 1996 (ISBN 0582 41626 4)

APPENDICES – SUPPORTING KNOWLEDGE OUTLINE

Knowledge, understanding and proficiency	Total hours for lectures and laboratory work	Total hours
Appendix 1		
1.1 BASIC ENGINEERING SCIENCE		
1.1.1 Mass and Volume	3	
1.1.2 Dynamics	14	
1.1.3 Energy, Work and Power	12	
1.1.4 Fluids	12	
1.1.5 Heat	9	50
Appendix 2		
2.1 MATHEMATICS		
2.1.1 Calculations with Positive and Negative Integers	18	
2.1.2 Simplifying Expressions	12	
2.1.3 Indices	9	
2.1.4 Calculations	9	
2.1.5 Algebra	18	
2.1.6 Trigonometry	18	
2.1.7 Mensuration	10	
2.1.8 Graphs	6	100 ¹
Appendix 3		
3.1 THERMODYNAMICS		
3.1.1 Thermodynamic Properties	4	
3.1.2 Thermodynamic Energy	8	
3.1.3 Thermodynamic Systems	1	
3.1.4 Energy Change	6	
3.1.5 Heat Transfer	16	
3.1.6 Vapours	16	
3.1.7 Ideal Gases	15	
3.1.8 Thermodynamic Processes	12	
3.1.9 Work Transfer	12	90
Appendix 4		
4.1 MECHANICS		
4.1.1 Statics	24	
4.1.2 Dynamics	20	
4.1.3 Hydrostatics	10	
4.1.4 Hydraulics	6	60
Appendix 5		
5.1 INDUSTRIAL CHEMISTRY		
5.1.1 Chemical Fundamentals	6	
5.1.2 Acidity/Alkalinity	3	
5.1.3 Corrosion	12	
5.1.4 Water Testing and Treatment	12	
5.1.5 Introduction to Fuels and Lubricants	12	45
Total hours:		345

¹ These hours will need to be substantially increased if trainees commence the course without a reasonable mathematical background.

APPENDIX 1: BASIC ENGINEERING SCIENCE

Textbooks: T13, T25

Teaching aids:A1

TRAINING OUTCOME

Demonstrates a knowledge and understanding of:

1.1 Mass and Volume (3 hours)

- Defines:
 - volume v
 - mass
 - centre of gravity
 - density as mass/volume—units are kg/m³
 - relative density
- explains that for homogeneous masses the centre of gravity lies at the centre of volume
- solves simple problems involving the above objectives
- measures density of liquids, using a hydrometer

1.2 Dynamics (14 hours)

The Relationship Between Speed, Acceleration, Mass, Force and Resistance

- defines speed as $\frac{\text{distance travelled}}{\text{time}}$ units are m/s or km/h
- calculates mean speeds, given time and distance
- defines acceleration (for motion in a straight line) as change of $\frac{\text{speed}}{\text{time}}$
- plots speed–time graphs for straight–line motion
- defines free fall acceleration as 9.8 m/s²
- solves problems using $\text{distance} = \text{speed} \times \text{time}$
- uses the equation $v = u + at$ to solve problems
- states that, in order to accelerate a mass, a force has to be applied
- states that the unit of force is the Newton (N)
- states that one Newton is the force which causes a mass of one kilogram to accelerate at the rate of 1m/s²
- states Newton's first law
- states Newton's second law
- defines weight as a force caused by gravitational attraction towards the centre of the earth
- uses the equation $F = ma$ to solve simple problems
- identifies practical examples of the effect of friction
- defines friction
- states that force is required to overcome the effects of friction
- explains in general terms the factors which affect frictional resistance to motion

1.3 Energy, Work and Power (12 hours)

The Relationship Between Forms of Energy, Work and Power

- states that common fuels such as hydrocarbons are sources of energy
- defines work as force \times distance travelled (newtons \times metres); unit is the joule (J)
- define the relationship between energy and work
- defines potential energy
- defines kinetic energy and derives the equation $\frac{mv^2}{2}$
- solves simple problems involving force, distance and work
- relates the work done to accelerate an object to its change of kinetic energy
- defines inertia
- using given data, draws graphs of force and distance moved and relates the area under the graphs to work done

- gives examples of the conversion of energy from one form to another
- defines efficiency in terms of input and output
- defines power as the rate of transfer of energy or the rate of doing work, i.e.
$$\frac{\text{energy transfer (joules)}}{\text{time taken (seconds)}}$$
- states that the unit of power is the watt (W)
- solves simple problems relating to the above objectives

1.4 Fluids (12 hours)

The Effect of Pressure, its Relationship to Depth of Liquid and Force

- defines a fluid
- defines pressure, i.e. $\frac{\text{force (newtons)}}{\text{area (metres}^2\text{)}}$
- states that the unit of pressure is the pascal (Pa)
- states that a practical unit of pressure is 10^5 newton/m² and is 1 bar
- states that atmospheric pressure is approximately 1 bar
- solves problems involving force, area and pressure
- states that the pressure at any level in a fluid is equal in all directions
- states that pressure acts in a direction normal to a surface
- states that the pressure at any level in a liquid depends upon the vertical height to the liquid surface (its head) and the density of the liquid
- explains in simple terms what is meant by:
 - atmospheric pressure
 - vacuum
 - partial vacuum
 - absolute zero pressure
 - gauge pressure
- draws a simple diagram of a:
 - piezometer
 - manometer
 - simple barometer
 - bourdon pressure gauge
- solves simple problems involving $9.8 \times \text{head} \times \text{density}$

1.5 Heat (9 hours)

The Relationship Between Temperature, Heat Energy and Heat Transfer

- explains what is meant by the temperature of a substance
- defines the Celsius scale and its fixed points
- defines the Kelvin
- measures temperature, using a mercury-in-glass thermometer
- defines the calorific value of a fuel
- solves simple problems, using the equation:
$$\text{heat transfer} = \text{mass of fuel} \times \text{calorific value}$$
- solves problems involving calorific value, mass of fuel, work done, energy transfer, fuel flow rates and efficiency
- defines specific heat capacity
- solves problems involving mass, specific heat capacity and temperature change
- explains in simple terms what is meant by:
 - conduction
 - convection
 - radiation
- gives examples of heat transfer by each of the processes described in the above objective

- explains the effect of raising their temperature on the physical dimensions of solids, liquids and gases
- gives examples where the above objective:
 - has to be allowed for
 - is used to advantage

APPENDIX 2: MATHEMATICS

The mathematics presented in this Appendix covers the teaching required to support marine engineering knowledge, understanding and proficiency for:

Officer in Charge of an Engineering Watch (Model Course 7.04), and Chief and Second Engineer Officer (Model Course 7.02)

Textbooks:

Teaching aids:

TRAINING OUTCOME

Demonstrates a knowledge and understanding of:

1.1 Calculations with positive and negative integers

- perform calculations with positive and negative integers involving the following processes:
 - addition
 - subtraction
 - multiplication
 - division
- defines the parts of a fraction as the numerator and denominator
- simplifies fractions by cancellation
- adds, subtracts, multiplies and divides fractions and simplifies the results
- solves problems, using one or more of the operations in the above objective

1.2 Simplifying expressions

- solves problems, using ratios
- applies the four basic arithmetic operations to expressions involving decimals
- converts a decimal to a fraction and vice versa
- recognizes recurring decimals as non-terminating decimals
- reduces a decimal number to a specified number of decimal places
- reduces a decimal number to a specified number of significant figures
- adds and subtracts decimal numbers
- multiplies and divides decimal numbers, giving answers to a specified number of decimal places and significant figures
- solves problems involving more than one of the operations in the above objectives

1.3 Indices (9 hours)

- Recognizes numbers involving indices, powers and roots
- applies the following rules, where m and n are integers:

$$a^m \times a^n = a^{m+n}$$

$$\frac{a^m}{a^n} = a^{m-n}$$

- deduces that $a^0 = 1$ and that $a^{-n} = \frac{1}{a^n}$
- expresses a binary number in the standard form of mantissa and exponent
- converts to normal decimal form a number given in standard form
- adds, subtracts, multiplies and divides two numbers given in standard form
- defines logarithms to the base of 10 and to the base of e (i.e. 2.718)
- uses logarithm tables to solve problems
- evaluates numbers raised to powers ranging from powers of 1.2 to 1.9
- states the meaning of and the symbol for prefixes for powers to ten, including: mega, kilo, hecto, deca, centi, milli, micro, nano and pico

1.4 Calculations (9 hours)

- defines percentage
- expresses one quantity as a percentage of another
- expresses increase and decrease as a percentage
- estimates the appropriate value of arithmetic problems and compares with given correct and false answers
- adds, subtracts, multiplies and divides numbers
- determines reciprocals, squares, square roots and fractional indices
- performs arithmetic operations on a calculator
- evaluates expressions, using realistic problems and the processes covered by the above objectives

1.5 Algebra (18 hours)

- states that an algebraic expression is a statement in which numerical quantities have been replaced by letters or other suitable symbols
- reduces an algebraic expression to its simplest form
- factorizes expressions by the extraction of a common factor
- applies any of the arithmetic expressions
- simplifies expressions when quantities are placed within brackets
- simplifies expressions when positive or negative signs are placed in front of a bracket
- solves linear equations with one unknown
- applies the rules which govern the transposition of quantities such as:

$$V = IR; A = x^2, L_1 = L(1 + t); v = u + at, E = \frac{mv^2}{2}$$

- expands the following:
 $(a + b)^2$
 $(a + b)^3$
 $(a + b)(a - b)$
- solves simultaneous equations with two unknowns
- solves problems by forming an equation, initially in algebraic, finally in numeric form
- solves quadratic equations by using the formula method

1.6 Trigonometry (18 hours)

- describe the measurement of angles in degrees and radians
- sketches and names the following angles: obtuse, right, complementary, supplementary and reflex
- defines a degree as 1/360 of a revolution and a minute as 1/60 of a degree
- defines a radian
- converts angular measurement into radians and vice versa
- defines sine, cosine and tangent from trigonometric tables
- uses the theorem of Pythagoras to find the length of one side in a right-angled triangle
- states that the sum of angles inside a triangle is 180°
- applies numerical solutions in respect of the side and angles of a right-angled triangle
- solves problems, given the equations, using:
 - the sine rule
 - the cosine rule
- demonstrates that $\cos \omega t = \sin \left(\omega t \pm \frac{\omega}{2} \right)$
- shows that $\sin^2 \omega t = \frac{1 - \cos 2\omega t}{2}$
- shows that $\sin \theta \cos \theta = \frac{\sin 2\theta}{2}$
- applies positive and negative values as appropriate to the sines, cosines and tangents Of angles between 0° and 360°

1.7 Mensuration (10 hours)

- states and applies formulae to find the area of the following:
 - a circle
 - a sector of a circle
 - a triangle
 - parallelogram
 - a trapezium
- defines a centroid
- states the position of the centroid of common regular shapes
- deduces a formula for the areas of a segment of a circle
- defines volume, for shapes having a constant cross-sectional area, as the product of area and length
- applies formulae to find the volume of the following:
 - a cube
 - a cylinder
 - a sphere
 - a triangular prism
- defines centre of volume
- states the position of the centre of volume of common solids
- uses the mid-ordinate rule to find the area of irregular figures
- uses Simpson's 1st and 2nd rules to find the area of irregular figures
- uses Simpson's 1st and 2nd rules to find the volume of irregular objects

1.8 Graphs (6 hours)

- draws axes for positive values
- defines and labels axes
- from given data, determines suitable scales
- plots points accurately, given co-ordinates
- draws smooth graphs through plotted points
- plots sine waves
- plots cosine waves
- determines the co-ordinates of intersecting curves or lines
- draws graphs of values with positive, negative and mixed co-ordinates
- states that the average value of a sine wave and a cosine wave is zero
- indicates changing rates on graphs
- explains the concept of $\frac{dy}{dx}$
- defines an elemental area
- explain the concept of integration

APPENDIX 3: THERMODYNAMICS (90 hours)

Textbooks:

Teaching aids:

TRAINING OUTCOME

Demonstrates a knowledge and understanding of:

1.1 Thermodynamic Properties (4 hours)

- describes the properties used to specify the state, or condition, of a substance, the units in which the property is measured and the usual symbol, e.g.
 - pressure
 - temperature
 - volume
 - energy
- explains what is meant by:
 - absolute quantities
 - specific quantities
 - intensive values
 - extensive values
- explains that a substance can exist in three states, or phases, which are:
 - solid
 - liquid
 - gaseous
- describes the energy required to change phase as:
 - enthalpy of fusion (solid—liquid)
 - enthalpy of evaporation (liquid—vapour)
- states that a change of phase is a constant—temperature process
- explains that fluids can have a liquid or a gaseous form

1.2 Thermodynamic Energy (8 hours)

- states that "internal" or "intrinsic" energy (U) is related to the motions of the molecules of a substance or a system
- states that internal energy is derived only from molecular motions and vibrations, is dependent only on thermodynamic temperature and is energy stored in the molecules
- states that the total energy stored in a body, or system, is termed enthalpy (H)
- defines total stored energy the sum of internal energy and the product of pressure (P) And volume (V), i.e. $H = U + PV$
- defines potential energy as energy stored in the molecules by virtue of their vertical Position above some datum level
- defines kinetic energy as energy stored in molecules by virtue of their velocity; kinetic energy has a value of $\frac{v^2}{2}$ (i.e. 0.5 of velocity squared) per unit mass of substance
- states that energy in transition between bodies or systems can only be heat flow (or Heat transfer) (Q) and work flow (or work transfer) (W)
- defines the first law of thermodynamics as "the energy stored in any given thermodynamic system can only be changed by the transition of energies Q and/or W "
- solves problems to demonstrate the above objectives

1.3 Thermodynamic Systems (1 hour)

- states that systems are identified in terms of mass of substance (i.e. molecules) contained within a system and/or the mass entering and leaving
- states that this identification is of importance when evaluating property changes taking place during thermodynamic operations

1.4 Energy Change (6 hours)

- explains that the "non-flow" equation derives directly from the first law of thermodynamics and is applicable only to "closed" systems (i.e. no molecules of substance are entering or leaving the system during the thermodynamic operation)
- defines the general form of the non-flow equation as $(U_2 - U_1) = \pm W \pm Q$
- explains that the mathematical sign associated with the transition energies of Q and W will be governed by "direction", i.e. whether the energy transfer is "into" or "out of" the closed system
- solves simple problems concerning energy changes in practice

1.5 Heat Transfer (16 hours)

- states that heat transfer can take place by conduction, convection and radiation and that when substances at different temperatures are placed in contact they will, in time, reach a common temperature through transfer of heat
- defines specific heat capacity as the heat transfer, per unit mass, per unit of temperature change, for any given body or system
- uses laboratory equipment to determine:
 - specific heat capacity of substances
 - final temperature of mixtures, and verifies the observed value by calculation
- states that the Fourier law for the conduction of heat through a substance as given by
$$Q = \frac{\lambda A e t}{x}$$
- identifies the quantities in the Fourier law as
 - Q = heat flow, measured in joules
 - A = surface area, measured in square metres
 - e = temperature difference between the surface, measured in °C
 - t = time interval, measured in seconds
 - x = distance travelled between the surface by the heat, measured in metres
 - λ = the coefficient of thermal conductivity
- explains that the units for the coefficient of thermal conductivity are watts per metre per kelvin i.e. $\frac{\text{joules} \times \text{metres}}{\text{second} \times \text{metres}^2 \times \text{kelvin}}$
- solves simple numerical problems involving heat transfer between substances when placed in contact with each other; to include mixtures of liquids and solids placed in liquids
- solves simple problems on the application of the Fourier law to solid homogeneous materials
- performs laboratory work to verify the above objective

1.6 Vapours (16 hours)

- defines the vapour phase as intermediate stage between the solid and the perfect gas state, and the property values, such as pressure, energy, volume
- states that the important fluids in this group are H₂O (i.e. steam) and the refrigerants
- defines the following conditions:
 - saturated vapour
 - dry vapour
 - wet vapour
 - dryness fraction
 - superheated vapour
- explains and uses the "corresponding" relationship that exists between pressure and temperature for a saturated liquid or saturated vapour
- demonstrates the above objective, using laboratory equipment
- uses tables of thermodynamic properties to determine values for enthalpy, internal energy and volume at any given condition of pressure and/or temperature defined in the above objective

1.7 Ideal Gases (15 hours)

- states the "critical temperature" as being the limit of the liquid phase
- defines an "ideal" gas as one which behaves almost as a perfect gas, whose temperature is above the critical one and whose molecules have a simple monatomic structure
- states that an "ideal" gas cannot be liquefied by alteration of pressure alone
- states the laws of Boyle and Charles and identifies the following statements with them:
 - $P \times V = a$ constant – Boyle
 - $\frac{V}{T} = a$ constant – Charles
- sketches a P – V curve demonstrating Boyle's law
- sketches a graph of V and T , demonstrating Charles' law
- states that the result of combining the laws of Boyle and Charles is:
 - $\frac{PV}{T} = a$ constant
- defines the specific ideal gas equation as:
 - $\frac{PV}{T} = R$, per unit mass of gas
- explains that R will have a different numerical value for each ideal gas or mixture of Ideal gases
- applies simple numerical calculations involving the elements of the above objectives

1.8 Thermodynamic Processes (12 hours)

- defines a thermodynamic process as "an operation during which the properties of state, pressure, volume and temperature may change, with energy transfer in the form of work and/or heat flow taking place"
- states that the following processes are applicable to ideal gases and vapours:
 - heat transfer: heating and cooling
 - work transfer; compression and expansion
- explains in simple terms the second law of thermodynamics
- explains with the aid of a sketched P – V diagram, where appropriate, the following "standard" processes;
 - pressure remaining constant
 - volume remaining constant
 - temperature remaining constant
 - zero heat transfer
 - polytropic expansion and compression
- describes a process of constant temperature as "isothermal"
- describes a process in which there is no heat transfer as "adiabatic"
- describes practical applications of the process described in the above objectives
- solves simple numerical problems relating to the elements in the above objectives

1.9 Work Transfer (12 hours)

- explains that "work" is calculated by force \times distance moved by that force
- sketches a P – V diagram relating the area of the diagram to the work done when a fluid exerts constant pressure on a piston in a cylinder
- explains the work transfer for a vapour or an ideal gas terms of pressures and volumes
- sketches a P – V diagram, relating the area of the diagram to work done on or by a piston in a cylinder during polytropic expansion and compression
- states the equation for work transfer, i.e.

$$W = \frac{P_1 V_1 - P_2 V_2}{n - 1}$$

where: W is the work done, in joules

P is the pressure at specific points in the process, in newtons/m²

V is the volume at the same points as for pressure, in m³ n is a numerical index

- states that the numerical index n is derived by experiment, using the equation
$$(P_1 V_1)^n = (P_2 V_2)^n$$
- states that, for most practical operations, n has numerical values between 1.2 and 1.5
- applies simple numerical calculations related to the elements in the above objectives

APPENDIX 4: MECHANICAL SCIENCE (60 hours)

TRAINING OUTCOME

Demonstrates a knowledge and understanding of:

1.1 Statics (24 hours)

- defines scalar and vector quantities, giving examples, e.g. mass and weight
- defines force
- shows force as a graphic representation
- uses the parallelogram of forces to obtain the resultant of two forces acting as a Common point
- states the principle of equilibrium
- defines the equilibrant
- states the necessary conditions for three forces to be in equilibrium
- defines the triangle of forces
- describes the polygon of forces
- defines the condition for equilibrium in the polygon of forces
- defines the net effect of a number of forces acting at a common point as the resultant
- defines the moment of a force about a point
- determines the moment produced by a couple
- describes the conditions required for equilibrium when a number of forces and moments act on a body
- balances moments
- resolves a force into a force and a couple
- defines the factors which govern the stability and overturning of a box
- states that the centre of gravity of a mass suspended from a single point lies vertically below the point of suspension
- states that the centre of gravity of a mass supported by a single point lies vertically above the point of support
- solves simple numerical and graphical problems related to the elements in the above objectives

1.2 Dynamics (20 hours)

Velocity and the Effect of Change of Direction

- defines velocity as a vector quantity
- plots graphs of velocity against time
- defines relative velocity
- determines average velocity from initial and final values of velocity
- states that the area enclosed by a velocity–time curve is distance
- defines acceleration in terms of initial and final values of velocity
- solves simple problems, using the equations

$$v = u \pm at$$
$$v^2 = u^2 \pm 2as$$
$$s = ut \pm \frac{at^2}{2}$$

- defines velocity as a graphic representation
- uses the parallelogram and the triangle of velocities to obtain resultant velocity

Friction

- defines friction in the horizontal plane
- defines the force required to overcome friction in the horizontal plane as

$$F = \mu N$$

where: F = force in newtons

N = normal (i.e. 90°) reaction force between contact surfaces

μ = coefficient of friction

- solves simple numerical problems related to the elements in the above objectives

1.3 Hydrostatics (10 hours)

- states the formulae for the pressure exerted by a liquid at any given vertical depth
- deduces the equation $F = 9.81 \times \text{head} \times \text{density} \times \text{area}$, to give the force on the surfaces of a rectangular tank when filled with liquid
- defines the effect of 'sounding pipes', 'air release pipes' or other 'standpipes' when containing liquid
- defines, with the aid of sketches, a hydraulic lifting machine
- applies simple numerical calculations related to the elements in the above objectives

1.4 Hydraulics (6 hours)

- describes the different energies stored in a liquid when in motion as potential energy, pressure energy and kinetic energy
- defines the "head of a liquid"
- states the energy components in a moving liquid in terms of its head
- states the expression to give the volumetric flow of liquid as its $\text{velocity} \times \text{cross-sectional area}$, measured in m³/second
- states the expression to give the mass flow of liquid as its $\text{velocity} \times \text{cross-sectional area} \times \text{density}$, measured in kilogram/second
- solves simple problems concerning the above objectives

APPENDIX 5: INDUSTRIAL CHEMISTRY (45 hours)

Textbooks:

Teaching aids:

TRAINING OUTCOME

Demonstrates a knowledge and understanding of:

1.1 Fundamentals (6 hours)

- defines an atom
- describes a molecule
- defines:
 - chemical elements
 - chemical compounds
- explains the difference between compounds and mixtures and names of:
 - elements
 - compounds
 - mixtures
- defines a chemical reaction
- defines an oxide
- uses as necessary the convention denoting elements, compounds and mixtures by letters and numbers; for example, carbon dioxide represented by CO_2
- explains what is meant by:
 - solution
 - solubility
 - saturated solution
 - suspension
 - precipitation

1.2 Acidity/Alkalinity (3 hours)

- defines the composition of an atom
- explains the result of an atom gaining or losing electrons
- defines a hydrogen ion
- defines a hydroxyl ion
- given pH values, demonstrates whether a solution is alkaline, neutral or acidic, indicating its strength or weakness
- uses an indicator such as litmus paper to determine whether a solution is acid or alkaline

1.3 Corrosion (12 hours)

- defines how metallic hydroxide is formed when an iron is immersed in an acidic solution
- defines the effect of dissolved oxygen and high acidity on polarization
- states that boiler water should be alkaline and contain little or no dissolved oxygen
- explains the fundamental process of corrosion
- names common engineering materials which produce passive oxide films
- states the main cause of corrosion
- names the components of a galvanic cell and applies these to the corrosion of a metal
- defines that seawater is an electrolyte
- defines an anode
- from a list of common metals, selects relative anodes
- defines metals as being noble or base relative to each other
- defines the use of sacrificial anodes
- recognizes the problems if graphite grease is used when seawater is present
- defines practical means of reducing galvanic action in the choice of metal and exposed surface area

- defines pitting corrosion
- recognizes the process of graphitization of cast iron
- defines the reasons why corrosion increases when seawater velocity increases
- defines the terms and what is meant by stress corrosion and names the metals in which it commonly occurs
- explains what is meant by dezincification and dealuminification
- defines how the process in the above objective can be prevented
- explains what is meant by fretting corrosion
- defines the factors which increase the rate of fretting
- defines what is meant by corrosion fatigue
- identifies the major factors affecting the corrosion process as:
 - differential temperatures
 - stresses within the metal structure
 - variation in crystal structure of the metal
 - distribution/concentration of impurities in the metal crystals
 - flow of oxygen to the cathode
 - flow of carbon dioxide to the anode and cathode
 - hydroxyl ion concentration of the aqueous solution
- recognizes that some films and coatings on metal surfaces can provide protection so long as they remain intact
- recognizes that surface preparation prior to the application of protective coatings is very important
- identifies the important methods of surface protection as:
 - paints
 - chemical films
 - metallic coatings
 - anodizing

1.4 Water testing and treatment (12 hours)

- recognizes the importance of controlling the pH value of aqueous solutions within the minimum corrosive range
- identifies the chemical additives that can be used to obtain the condition required in the above objective
- knows the importance of maintaining a gas-free condition in the water used to "feed" a steam boiler or to circulate in an engine cooling system
- identifies the methods in common use for conditioning the water content of marine Power plant, e.g. trisodium phosphate, hydrazine
- explains that natural water supplies contain metallic salts in solution
- demonstrates the standard method of measuring metallic salt content, i.e. state the Actual quantity of metallic salt present in a specified quality of water
- knows the standard measurement given in the above objective as in units of "parts per million" (ppm) or less accurately in '32's' (seawater density measurement)
- lists the main metallic salts found in:
 - fresh water
 - average seawater
- defines:
 - permanent hardness
 - temporary hardness
- defines briefly how scale and sludge are produced in a steam boiler
- explains the different effects of using seawater, fresh water and distilled water as boiler feedwater
- defines the principal objects of treatment of boiler feedwater

1.5 Introduction to fuels and Lubricants (12 hours)

- identifies the average carbon, hydrogen, sulphur and ash content of the following fuels:
 - petrol
 - kerosene
 - marine diesel fuel
 - boiler fuel oil
 - defines flashpoint and explains its importance for marine fuels and lubricants
 - knows flashpoint temperature for the following hydrocarbons:
 - petrol
 - kerosene
 - marine diesel fuel
 - boiler fuel oil
 - lubricating oil
 - identifies the minimum closed flashpoint of marine fuels
 - states the maximum temperature to which fuel oil may be raised
 - describes precautions taken on board ship to prevent accidental ignition of the oils listed in the above objective
 - defines viscosity in terms of resistance to flow
 - demonstrates why it is necessary to raise the temperature of some fuel oils
 - carries out tests on fuels and lubricants for:
 - flashpoint
 - viscosity
 - explains the reason why values of flashpoint or of viscosity need to be known for the following:
 - fuels and lubricants in storage
 - transfer of fuels and lubricants
 - carries out tests on fuels and lubricants for water content
-