

SUB-COMMITTEE ON STANDARDS OF  
TRAINING AND WATCHKEEPING  
43rd session  
Agenda item 3

STW 43/3/7  
10 October 2011  
Original: ENGLISH

## VALIDATION OF MODEL TRAINING COURSES

### Model Course – Chief Engineer Officer and Second Engineer Officer

#### Note by the Secretariat

#### SUMMARY

*Executive summary:* This document contains a revised draft model course on Chief Engineer Officer and Second Engineer Officer

*Strategic direction:* 5.2

*High-level action:* 5.2.2

*Planned output:* 5.2.2.5

*Action to be taken:* Paragraph 3

*Related document:* STW 40/14

1 Attached in the annex is the revised draft model course on Chief Engineer Officer and Second Engineer Officer.

2 The preliminary revised draft of this model course was forwarded to members of the validation panel for their comments. Relevant comments on the revised draft course have been received from the validation panel and incorporated, as appropriate.

#### Action requested of the Sub-Committee

3 The Sub-Committee is invited to consider the above information and take action as appropriate.

\*\*\*



**ANNEX**

**DRAFT IMO MODEL COURSE ON CHIEF ENGINEER OFFICER  
AND SECOND ENGINEER OFFICER**

**MODEL  
COURSE  
7.02**

**CHIEF ENGINEER OFFICER AND  
SECOND ENGINEER OFFICER**

**XXXX Edition**

### **ACKNOWLEDGEMENTS**

This course for Chief Engineer Officer and Second Engineer Officer is based on material developed by Anglo Eastern Maritime Training Centre and Australian Maritime College for IMO under the guidance of GlobalMET.

IMO wishes to express its sincere appreciation to GlobalMET for its provision of expert assistance, valuable cooperation, and generous funding in support of this work.

## Contents

	<b>Page</b>
<b>Introduction</b>	
<b>Part A: Course Framework for all functions</b>	13
<b>Function 1: Marine Engineering at the Management Level</b>	
Part B1: Course Outline	35
Part C1: Detailed Teaching Syllabus	40
Part D1: Instructors Manual	72
<b>Function 2: Electrical, Electronic and Control Engineering at the Management Level</b>	
Part B2: Course Outline	93
Part C2: Detailed Teaching Syllabus	96
Part D2: Instructors Manual	110
<b>Function 3: Maintenance and Repair at the Management Level</b>	
Part B3: Course Outline	122
Part C3: Detailed Teaching Syllabus	124
Part D3: Instructors Manual	134
<b>Function 4: Controlling the Operation of the Ship and Care for Persons on Board at the Management Level</b>	
Part B4: Course Outline	146
Part C4: Detailed Teaching Syllabus	152
Part D4: Instructors Manual	179
<b>Part E: Evaluation</b>	207
<b>Guidance on implementation of IMO Model Courses</b>	216

## Introduction

### ■ Purpose of the model courses

The purpose of the IMO model courses is to assist maritime training institutes and their teaching staff to introduce and organise new training courses and enhance existing training material, whereby the quality and effectiveness of the training may be improved.

It is not the intention of the model course programme to present instructors with a rigid "teaching package" which they are expected to "follow blindly". Nor is it the intention to substitute audio-visual or "programmed" material for the instructor's presence. As in all training endeavours, the knowledge, skills and dedication of the instructors are the key components in the transfer of knowledge and skills to those being trained through IMO model course material.

The educational systems and the cultural backgrounds of trainees in maritime subjects vary considerably from country to country. For this reason, the model course material has been designed to identify the basic entry requirements and trainee target group for each course in universally applicable terms, and to specify clearly the technical content and levels of knowledge and skill necessary to meet the technical intent of IMO conventions and related recommendations.

This is the first major revision to this Model Course. In order to keep the training programme up to date in future, it is essential that users provide feedback. New information will provide better training in safety at sea and protection of the marine environment. Information, comments and suggestions should be sent to the Head of the STCW and Human Element Section at IMO, London.

### ■ Use of the model course

To use the model course the instructor should review the course plan and detailed syllabus, taking into account the information provided under the entry standards specified in the course framework. The actual level of knowledge and skills and the prior technical education of the trainees should be kept in mind during this review, and any areas within the detailed syllabus which may cause difficulties because of differences between the actual trainee entry level and that assumed by the course designer should be identified. To compensate for such differences, the instructor is expected to delete from the course, or reduce the emphasis on, items dealing with knowledge or skills already attained by the trainees. He should also identify any academic knowledge, skills or technical training which they may not have acquired.

By analysing the detailed syllabus and the academic knowledge required to allow training in the technical area to proceed, the instructor can design an appropriate pre-entry course or, alternatively, insert the elements of academic knowledge required to support the technical training elements concerned at appropriate points within the technical course.

Adjustment of the course objective, scope and content may also be necessary if in your maritime industry the trainees completing the course are to undertake duties which differ from the course objectives specified in the model course.

Within the course plan, the course designers have indicated their assessment of the time, which should be allotted to each area of learning. However, it must be appreciated that these allocations are arbitrary and assume that the trainees have fully met all entry requirements of the course. The instructor should therefore review these assessments and may need to re-allocate the time required to achieve each specific learning objective or training outcome.

## ■ Lesson plans

Having adjusted the course content to suit the trainee intake and any revision of the course objectives, the instructor should draw up lesson plans based on the detailed syllabus. Where no adjustment has been found necessary in the learning objectives of the detailed syllabus, the lesson plans may simply consist of the detailed syllabus with keywords or other reminders added to assist the instructor in making his presentation of the material.

## ■ Presentation

The presentation of concepts and methodologies must be repeated in various ways until the instructor is satisfied, by testing and evaluating the trainee's performance and achievements, that the trainee has attained each specific learning objective or training outcome. The syllabus is laid out in learning objective format and each objective specifies a required performance or what the trainee must be able to do as the learning or training outcome. Taken as a whole, these objectives aim to meet the knowledge, understanding and proficiency specified in the appropriate tables of the STCW Code.

## ■ Implementation

For the course to run smoothly and to be effective, considerable attention must be paid to the availability and use of:

- Properly qualified instructors
- Support staff
- Rooms and other spaces
- Workshops and equipment
- Suggested references, textbooks, technical papers, bibliography
- Other reference material.

Thorough preparation is the key to successful implementation of the course. IMO has produced a booklet entitled "Guidance on the implementation of IMO model courses", which deals with this aspect in greater detail.

In certain cases, the requirements for some or all of the training in a subject are covered by another IMO model course. In these cases, the specific part of the STCW Code, which applies, is given and the user is referred to the other model course.

## ■ **Course objective**

This model course comprises four functions at the management level. On successful completion of the course and the requisite watchkeeping experience, officers will be prepared for taking full responsibility for the safety of the ship, its passengers, crew and cargo. They will be aware of their obligations under international agreements and conventions concerning safety and the protection of the marine environment and will be prepared for taking the practical measures necessary to meet those obligations.

In this model course, one combined course has been written for both chief engineer officer and second engineer officer. The material is set out so that it can be run separately from the course for officer in charge of an engineering watch, but this is not intended to imply that it has to be run separately. It has been written in this manner so as to give Administrations the opportunity to arrange a structure best suited to their needs.

The teaching schemes should be carefully scrutinized to ensure that all of the tabulated training outcomes are covered, that repetition is avoided and that essential underpinning knowledge at any stage has already been covered. A certain amount of duplication under different subjects will probably occur, provided it is not excessive, the different approaches can provide useful reinforcement of work already learned. Care should be taken to see that items not included in the syllabus or treatment beyond the depth indicated by the objectives have not been introduced except where necessary to meet additional requirements of the Administration. The teaching scheme should be adjusted to take account of those matters and the timing of any modular courses (such as training in Fire Fighting), which are to be included.

## ■ **Entry standards**

Entrants should have successfully completed a course covering the minimum standards required for certification as officer in charge of an engineering watch in a manned engine-room or designate duty engineer in a periodically unmanned engine-room (see IMO Model Course No. 7.04 Officer in Charge of an Engineering Watch).

## ■ **Course intake limitations**

Class sizes should be limited to not more than 24 in order to allow the instructor to give adequate attention to individual trainees. Larger numbers may be admitted if extra staff and tutorial periods are provided to deal with trainees on an individual basis. In addition, for scheduling access to learning facilities and equipment, attention to strict time management is necessary. In large classes students should have their own reference books, unless sufficient copies can be provided in a central library. Classrooms should be big enough to seat all students so they can see and hear the instructor.



During practical sessions and group activities, there will be additional restraints on class size. Where applicable, a recommendation on class size is contained in the framework for each of the individual functions.

## ■ Textbooks, videos and bibliography

References to books, videos and bibliography are made in the Instructor's Manual of the individual subjects to aid both instructors and trainees in finding relevant information and to help in defining the scope and depth of treatment intended.

The mention of a particular textbook does not imply that it is essential to use that book only that it appeared to be best suited to the course at the time of its design. In many instances there are a number of suitable books and instructors are free to use whatever texts they consider to be most suited to their circumstances and trainees.

Every effort has been made to quote the latest editions of the publications mentioned but new editions are constantly being produced. Instructors should always use the latest edition for preparing and running their courses.

Full use should be made of technical papers and other publications available from maritime and other professional organizations. Such papers contain new developments in techniques, equipment, design, management and opinion and are an invaluable asset to a maritime training establishment.

## ■ Computer applications

In view of the rapid growth of information technology (IT) and widespread use of computers aboard ship, it is recommended that at the discretion of the Administration, computer applications at an advanced level should be included in the training for chief engineer officer and second engineer officer. If this topic has not been covered during training as officer in charge of an engineering watch some basic training will also be required.

Particulars of the training will depend upon the computer facilities available and the needs of the trainees. The following outline provides guidance on topics which could be included:

- The care and storage of magnetic media; use of simple utility programs for identifying disk problems and fixes; LAN maintenance; back-up management; virus protection.
- IT and the use of applications, for communications (e-mail, data, etc), the internet, intranets and the world-wide web (www).
- The installation and setup of multi-media applications.

In addition applications of computers and micro-processors to instrumentation and control systems, including:

- Simple digital circuits, binary logic switches, bistable circuits.
- Logic gates, truth tables of simple logic circuits.

- Representation of data by bits, bytes and words, binary and hexadecimal representation.
- Binary-coded decimal representation, fixed- and floating-point numbers, ASCII Code.
- Analogue-to-digital and digital-to-analogue converters.
- Computer architecture, information transfer between principal units.
- Memory, ROM, RAM, direct access memory, virtual memory.
- Input and output devices, data transfer, modems, multiplexers.
- Block diagrams of computer supervisory control systems and direct digital control systems.
- Automatic monitoring, data-recording and alarm systems.

The use of multi-media applications can enhance learning in topics in many areas of knowledge and prove of value to chief engineer officer and second engineer officer. Many of the IMO rules and Assembly Resolutions are available on CD-ROM. Up to date details may be found on the IMO web site at <http://www.imo.org>

## ■ Training and the STCW 2010 Convention

The standards of competence that have to be met by seafarers are defined in Part A of the STCW Code in the Standards of Training, Certification and Watchkeeping for Seafarers Convention, as amended in 2010. This IMO model course has been revised and updated to cover the competences in STCW 2010. It sets out the education and training to achieve those standards.

In common with the Convention, the course is organised under the seven functions at three levels of responsibility. Specifically, this course covers the minimum standard of competence for chief engineer officers and second engineer officers on ships powered by main propulsion machinery of 3,000 kW propulsion power or more, see STCW Code Table A-III/2.

For ease of reference, the course material is organised into four separate Functions as per the STCW Code. These functions are:

- Function 1 Marine engineering at the management level
- Function 2 Electrical, electronic and control engineering at the management level
- Function 3 Maintenance and repair at the management level
- Function 4 Controlling the operation of the ship and care for the persons on board at the management level.

Each function is addressed in 4 parts: Part A which is common for all functions, Part B, Part C and Part D.

Part A provides the framework for the course with its aims and objectives and notes on the suggested teaching facilities and equipment. A list of useful teaching aids which includes videos, CBT, IMO references, textbooks and bibliography is included in function 1, which affects all the 4 functions.

Part B provides an outline of lectures, demonstrations and exercises for the course. No detailed timetable is suggested. From the teaching and learning point of view, it is more important that the trainee achieves the minimum standard of competence defined in the STCW Code than that a strict timetable is followed. Depending on their experience and ability, some students will naturally take longer to become proficient in some topics than in others.

Part C gives the Detailed Teaching Syllabus. This is based on the theoretical and practical knowledge specified in the STCW Code. It is written as a series of learning objectives; in other words what the trainee is expected to be able to do as a result of the teaching and training. Each of the objectives is expanded to define a required performance of knowledge, understanding and proficiency. The objective, therefore, describes what the trainee must do to demonstrate that the specified knowledge or skill has been transferred.

Thus each training outcome is supported by a number of related performance elements in which the trainee is required to be proficient. The teaching syllabus shows the *required performance* expected of the trainee in the tables that follow.

## ■ Explanation of Information Contained in the Syllabus Tables

The information on each table is systematically organised in the following way. The line at the head of the table describes the FUNCTION with which the training is concerned. A function means a group of tasks, duties and responsibilities as specified in the STCW Code. It describes related activities, which make up a professional discipline or traditional departmental responsibility on board.

In this model course there are four functions:

- Marine engineering at the management level
- Electrical, electronic and control engineering at the management level
- Maintenance and repair at the management level
- Controlling the operation of the ship and care for the persons on board at the management level

The header of the first column denotes the **COMPETENCE** concerned. Each function comprises a number of competences. For example, the Function 1, Marine engineering at the Management Level, comprises a total of four **COMPETENCES**. Each **COMPETENCE** is uniquely and consistently numbered in this model course.

The first is **Manage the Operations of Propulsion Machinery**. It is numbered 1.1 that is the first competence in Function 1. The term competence should be understood as the application of knowledge, understanding, proficiency, skills and experience for an individual to perform a task, duty or responsibility on board in a safe, efficient and timely manner.

Shown next is the required **TRAINING OUTCOME**. The training outcomes are the areas of knowledge, understanding and proficiency in which the trainee must be able to demonstrate knowledge and understanding. Each **COMPETENCE** comprises a number of training outcomes. For example, the competence **Manage the Operations of Propulsion Machinery** comprises a total of seven training outcomes. The first concerns **DESIGN FEATURES AND OPERATIVE MECHANISM OF MARINE DIESEL ENGINE AND ASSOCIATED AUXILIARIES**. Each training outcome is uniquely and consistently numbered in this model course. **DESIGN FEATURES AND OPERATIVE MECHANISM OF MARINE DIESEL ENGINE AND ASSOCIATED AUXILIARIES** is numbered 1.1.1. and **THERMODYNAMICS AND HEAT TRANSMISSION IS NUMBERED 1.2.1**. For clarity training outcomes are printed in black in grey, for example **TRAINING OUTCOME**.

Finally, each training outcome embodies a variable number of required performances - as evidence of competence. The instruction, training and learning should lead to the trainee meeting the specified required performance. For the training outcome 1.2.1 *Thermodynamics and heat transmission*, there are twelve areas of performance. These are:

<b>1.2.1.1</b>	<b>Thermodynamic Fundamentals</b>
<b>1.2.1.2</b>	<b>Perfect Gas</b>
<b>1.2.1.3</b>	<b>Second Law</b>

and so on.

Following each numbered area of required performance there is a list of activities that the trainee should complete and which collectively specify the standard of competence that the trainee must meet. These are for the guidance of teachers and instructors in designing lessons, lectures, tests and exercises for use in the teaching process. For example, under the topic 1.2.1.1 Thermodynamic Fundamentals, to meet the required performance, the trainee should be able to explain:

- System and working substance.
- SI units. Property and State.
- Reversible and irreversible processes.
- Reversible work of compression or expansion.

and so on.

Note that it is not intended that lessons are organised to follow the sequence of required performances listed in the Tables. The Tables are organised to match with the competence in the STCW Code Table A-III/2. Lessons and teaching should follow college practices. It is not necessary, for example, for Materials for construction and repair to be studied before Safe working practices. What is necessary is that all the material is covered and that teaching is effective to allow trainees to meet the standard of required performance.

Part D gives the Instructor's Manual, which contains guidance notes for the Instructors and additional explanations. Suggested teaching aids, which includes IMO references and publications', textbook, videos, CBT's and bibliography are included to assist the teacher in preparing and presenting their lessons.

The material listed in the course framework has been used to structure the detailed teaching syllabus; in particular,

Teaching aids (indicated by Ax)  
IMO references (indicated by Rx)  
Textbooks (indicated by Tx)  
Videos (indicated by Vx)  
Bibliography (indicated by Bx)

will provide valuable information to instructors.

The Convention defines the minimum standards to be maintained in Part A of the STCW Code. Mandatory provisions concerning Training and Assessment are given in Section A-I/6 of the STCW Code. These provisions cover: qualification of instructors; supervisors as assessors; in-service training; assessment of competence; and training and assessment within an institution. The corresponding Part B of the STCW Code contains non-mandatory guidance on training and assessment.

The criteria for evaluating competence specified in the competence tables of Part A of the STCW Code have to be used in the assessment of all competences listed in those tables.

A separate IMO model course 3.12 addresses Assessment of Competence. This course explains the use of various methods for demonstrating competence and criteria for evaluating competence as tabulated in the STCW Code.

### ■ **Ships with main propulsion plant operated by steam boilers and steam turbines**

The function Marine Engineering at the Management Level includes competences concerned with the operation of main steam boilers and main steam turbine. These are addressed in the Detailed Teaching Syllabus in Part B and Part C at competence 1.1.7. Candidates for certification for service on ships in which main steam boilers and main steam turbines do not form part of their main propulsion plant may omit the competence 1.1.7. Certificates so awarded should not be valid for service on ships in which main steam boilers and main steam turbines form part of their propulsion machinery until the engineer officer meets the standard of competence in the items previously omitted. Such limitations are required to be shown on the certificate and in the endorsement.

### ■ **Responsibilities of Administrations**

Administrations should ensure that training courses delivered by colleges and academies are such as to ensure officers completing training do meet the standards of competence required by STCW Regulation II/1 paragraph 2.

## ■ **Validation**

The information contained in this document has been validated by the Sub-Committee on Standards of Training and Watchkeeping for use by technical advisers, consultants and experts for the training and certification of seafarers so that the minimum standards implemented may be as uniform as possible. Validation in the context of this document means that no grounds have been found to object to its content. The Sub-Committee has not approved this document, as it considers that the document must not be considered an official interpretation of the Convention.'

## **PART A: Course Framework for all functions**

### **■ Aims**

This model course aims to meet the mandatory minimum requirements for knowledge, understanding and proficiency in Table A-III/2 of STCW 2010 for the function Marine Engineering at the Management Level, for the function Electrical, Electronic and Control Engineering at the Management Level, for the function Maintenance and Repair at the Management Level and the background knowledge to support Controlling the Operation of the Ship and Care for Persons on Board at the Management Level.

### **■ Objective**

#### **Function 1**

The syllabus for Function 1 covers the requirements of the 2010 STCW Convention Chapter III, Section A-III/2. This functional element provides the detailed knowledge to support the training outcomes related to the Marine Engineering at the Management Level.

This section provides the background knowledge to support the tasks, duties and responsibilities in:

- managing the operation of propulsion plant machinery
- planning and scheduling operations *theoretical knowledge*
- operation, surveillance, performance assessment and maintaining safety of propulsion plant and auxiliary machinery *practical knowledge*
- managing fuel, lubrication and ballast operations.

#### **Function 2**

The syllabus of Function 2 covers the requirements of the 2010 STCW Convention Chapter III, Section A-III/2. This functional element provides the detailed knowledge to support the training outcomes related to Electrical, Electronic and Control Engineering at the Management Level.

This section provides the background knowledge to support the tasks, duties and responsibilities in:

- managing the operation of electrical and electronic control equipment *theoretical knowledge*
- managing trouble shooting and restoration of electrical and electronic control equipment to operating condition

#### **Function 3**

The syllabus of Function 3 covers the requirements of the 2010 STCW Convention Chapter III, Section A-III/2. This functional element provides the detailed knowledge to

support the training outcomes related to Maintenance and Repair at the Management Level.

This section provides the background knowledge to support the tasks, duties and responsibilities in:

- Managing safe and effective maintenance and repair procedures
- Detecting and identifying the cause of machinery malfunctions and correct faults *practical knowledge*
- Ensuring safe working practices *practical knowledge*

#### **Function 4**

The syllabus of Function 4 covers the requirements of the 2010 STCW Convention Chapter III, Section A-III/2. This functional element provides the detailed knowledge to support the training outcomes related to Controlling the Operation of the Ship and Care for Persons on Board at the Management Level.

This section provides the background knowledge to support the tasks, duties and responsibilities in:

- Controlling trim, stability and stress
- Monitoring and controlling compliance with legislation to ensure safety of life at sea and protection of the marine environment
- Maintaining safety and security of crew and passengers and the operational condition of the life saving, fire fighting and other safety system
- Developing emergency and damage control plans and handling emergency situation
- Using leadership and managerial skills

These include topics such as ship construction and stability, search and rescue, personnel management and contingency planning.

#### **■ Entry standards**

This course is principally intended for officers for certification as chief engineer and second engineer on ships powered by main propulsion machinery of 3000 kW propulsion power or more. Entrants should have successfully completed a course covering the minimum standards required for certification as officer in charge of an engineering watch (see IMO Model Course No. 7.04, Officer in Charge of an Engineering Watch) and have approved seagoing service, see STCW Regulation III/2.

#### **■ Course certificate**

On successful completion of the course and assessments, a document may be issued certifying that the holder has successfully completed a course of training which meets or exceeds the level of knowledge and competence specified in Table A-III/2 of STCW 2010, for the function.



A certificate may be issued only by centres approved by the Administration.

## ■ Staff requirements

Instructors shall be qualified in the task for which training is being conducted and have appropriate training in instructional techniques and training methods (STCW Code Section A1/6). As well as instructors, additional staff will be required for the maintenance of machinery and equipment and for the preparation of materials, work areas and supplies for all practical work.

## ■ Teaching facilities and equipment

A classroom equipped with an overhead projector and a blackboard or whiteboard or interactive board or flipchart should be provided for teaching the theory of the course and holding group discussions.

Administrations may wish to consider the provision of a large workshop, equipped to facilitate all of the engineering practice, in a single space. Such an arrangement can be quite efficient in the use of staff, materials, stores, tools, etc.

## ■ Teaching aids (A)

- A1 Instructor Manual (Part D of this course)
- A2 Ship's Drawings / Plan (GA, Shell expansion, Deck plan and Mid section)
- A3 Videos (DVDs), CD-ROMs, CBT's (V)
  - V1 DIESEL ENGINE CRANKCASE LUBRICATING OILS Code No: 126
  - V2 HANDLING & TREATMENT OF HEAVY FUELS Code No: 143
  - V3 INTERNAL CARE OF MARINE BOILERS Code No: 150
  - V4 HYDRAULIC OIL CONTAMINATION Code No: 166
  - V5 DIESEL FUEL INJECTION PUMPS Code No: 302
  - V6 MICROBIAL PROBLEMS IN FUELS Code No: 322
  - V7 PRINCIPLES OF LUBRICATION & GENERAL APPLICATION Code No: 442
  - V7A LUBRICATION, SLOW & MEDIUM SPEED MARINE DIESEL ENGINES Code No: 443
  - V8 LUBRICATION OF ANCILLARY EQUIPMENT - PART 3 Code No: 444
  - V9 MACHINERY ALARMS & PROTECTION DEVICES Code No: 528
  - V10 FUEL OIL BURNER THEORY AND DIAGNOSTICS Code No: 604
  - V11 AN INTRODUCTION TO HYDRAULICS Code No: 66
  - V12 EFFICIENT OPERATION OF MARINE DIESEL ENGINES Code No: 693
  - V13 SHIP'S ELECTRICAL SYSTEMS - SAFETY AND MAINTENANCE Code No: 665
  - V14 ELECTRICAL DISTRIBUTION Code No: 666
  - V15 GENERATORS AND MAIN CIRCUIT BREAKERS Code No: 667
  - V16 MOTORS AND STARTERS Code No: 668
  - V17 ANCILLARY ELECTRICAL SERVICES Code No: 669
  - V18 SPECIAL ELECTRICAL PRACTICE FOR OIL, GAS & CHEMICAL TANKERS Code No: 670

- V19 ELECTRICAL SURVEY REQUIREMENTS Code No: 671
- V20 ELECTRIC PROPULSION AND HIGH VOLTAGE PRACTICE Code No: 672
  
- V21 MARPOL ANNEX VI - PREVENTION OF AIR POLLUTION FROM SHIPS (Ed Code No: 1119
- V22 FIGHTING POLLUTION - PREVENTION OF POLLUTION FROM SHIPS EDIT Code No: 1122
- V23 CRISIS MANAGEMENT Code No: 507
- V24 FIRE PARTY OPERATIONS Code No: 509
- V25 THE INTERNATIONAL SAFETY MANAGEMENT CODE Code No: 524
- V26 LOAD LINE SURVEYS - PART 1 Code No: 544
- V27 SAFETY CONSTRUCTION SURVEY - PART 2 Code No: 545
- V28 SAFETY EQUIPMENT SURVEY - PART 3 Code No: 546
- V29 PERSONAL SAFETY IN THE ACCOMMODATION Code No: 554
- V30 PERSONAL SAFETY ON DECK Code No: 555
- V31 PERSONAL SAFETY IN THE ENGINE ROOM Code No: 556
- V32 PERSONAL SAFETY ON BULK CARRIERS Code No: 558
- V33 PERSONAL SAFETY ON GENERAL CARGO SHIPS Code No: 559
- V34 PERSONAL SAFETY ON CONTAINER SHIPS Code No: 560
- V35 PERSONAL SAFETY ON CAR CARRIERS & RORO'S Code No: 562
- V36 PERSONAL SAFETY ON PASSENGER SHIPS Code No: 563
- V37 THE SHIPBOARD MANAGEMENT ROLE (EDITION 2) Code No: 969
- V38 PERSONAL SAFETY ON TANKERS (EDITION 2) Code No: 970
- V39 PERSONAL SAFETY ON CHEMICAL TANKERS Code No: 980
- V40 THE ISM AUDIT Code No: 575
- V41 BUNKERING OPERATIONS - SAFE OIL TRANSFER PROCEDURES Code No: 588
- V42 MARINE RISK ASSESSMENT-THE FLEET Code No: 735
- V43 MANAGEMENT ON BOARD - PART 1 Code No: 607
- V44 GET SMART: ORGANISATION AND PLANNING - PART 2 Code No: 608
- V45 GET RESULTS: PLANNING FOR PROFIT - PART 3 Code No: 609
- V46 TEAMWORK - PART 4 Code No: 610
- V47 MOTIVATING INDIVIDUALS - PART 5 Code No: 611
- V48 COMMUNICATION - PART 6 Code No: 612
- V49 PERMIT TO WORK Code No: 621
- V50 SEVEN STEPS TO SHIP STABILITY PART 1 Code No: 622
- V51 SEVEN STEPS TO SHIP STABILITY PART 2 Code No: 623
- V52 WASTE AND GARBAGE MANAGEMENT Code No: 627
- V53 MACHINERY SPACE FIRES (EDITION 3) Code No: 677
- V54 ENCLOSED LIFEBOATS, FREEFALL LIFEBOATS RESCUE BOATS Code No: 679
- V55 ENTERING INTO ENCLOSED SPACES (EDITION 2) Code No: 682
- V56 OPERATIONS & PERSONAL SAFETY IN DRY DOCKS & REPAIR YARDS Code No: 692
- V57 BALLAST WATER MANAGEMENT Code No: 698
- V58 CREW RESOURCE MANAGEMENT - ENGINE ROOM Code No: 929
- V59 PORT STATE CONTROL Code No: 821

Available from: Videotel Marine International  
84 Newman Street, London W1T 3EU, UK  
Tel: +44(0) 20 72991800  
Fax: +44(0) 207299 1818  
E-mail: [mail@videotelmail.com](mailto:mail@videotelmail.com)  
URL: [www.videotel.co.uk](http://www.videotel.co.uk)

V60 BALLAST WATER MANAGEMENT - WHAT YOU REALLY NEED TO KNOW

Available from: Walport International Ltd,  
Riverside Business Centre,  
Fort Road,  
Tilbury,  
Essex,  
RM18 7ND,  
United Kingdom  
*Telephone:* +44 (0)1375 489 790  
*Fax:* +44 (0)1375 489 794  
*Email:* [sales@walport.com](mailto:sales@walport.com)  
URL: [www.walport.com](http://www.walport.com)

- V61 REMOTE CONTROL SYSTEM, AUTOCHIEF 4 (CBT #0019)
- V62 OPERATION OF GENERATORS (CBT #0041)
- V63 AUTOMATION, VISCOSITY CONTROL (CBT # 0083)
- V64 INERT GAS GENERATOR (CBT # 0007)
- V65 FUELGAS PLANT (CBT # 0008)
- V66 FUELOIL SYSTEM (CBT # 0009)
- V67 MARINE FUEL HANDLING (CBT # 0010)
- V68 STEERING GEAR (CBT # 0017)
- V69 COOLING SYSTEM (CBT # 0018)
- V70 AUXILIARY ENGINE (CBT # 0024)
- V71 MARINE LUBRICANTS (CBT # 0030)
- V72 AC4, DIGITAL GOVERNOR SYSTEM (CBT # 0034)
- V73 BILGE WATER SEPARATOR (CBT # 0043)
- V74 AUXILIARY BOILER PLANT (CBT # 0046)
- V75 FUEL COMBUSTION EFFICIENCY (CBT # 0047)
- V76 BASIC REFRIGERATION THEORY (CBT # 0069)
- V77 BASIC HYDRAULICS (CBT # 0072)
- V78 SULZER MEDIUM SPEED DIESEL ENGINE (CBT # 0074)
- V79 PUMPS AND PUMPING OPERATIONS (CBT # 0078)
- V80 INCINERATORS (CBT # 0091)
- V81 FLEXINERT GAS GENERATOR (CBT # 0094)
- V82 ENERGY CONSERVATION (CBT # 0097)
- V83 FRESH WATER GENERATOR (CBT # 0098)
- V84 AC4 SULZER DENIS 1 (CBT # 0110)
- V85 AC4 MAN B AND W (CBT # 0116)
- V86 STEERING GEAR, RAM TYPE (CBT # 0118)
- V87 ALCAP (SEPARATION PRINCIPLES) (CBT # 0162)
- V88 MARINE FUEL PROPERTIES II (CBT # 0179)

- V89 VESSEL STRUCTURAL CONDITIONS (CBT # 0014)
- V90 PROTECTION AND INDEMNITY (CBT # 0028)
- V91 HULL AND MACHINERY (CBT # 0029)
- V92 INSPECTIONS (CBT # 0035)
- V93 CRISIS MANAGEMENT (CBT # 0073)
- V94 RISK ASSESSMENT AND MANAGEMENT (CBT # 0123)
- V95 HOTWORK (CBT # 0125)
- V96 ENCLOSED SPACE ENTRY (CBT # 0127)

Available from: Seagull AS  
P.O. Box 1062  
N-3194 Horten, Norway  
Phone: +47 33 03 09 10  
Fax: +47 33 04 62 79  
Email: [seagull@sgull.com](mailto:seagull@sgull.com)

- V97 STATIC ELECTRICITY ON BOARD TANKERS
- V98 ENCLOSED SPACE ENTRY -PERILS & PRECAUTIONS
- V99 ENCLOSED LIFEBOAT-ON LOAD RELEASE GEAR
- V100 FREE FALL LIFE BOATS "RELEASE MECHANISM

Available from: Available from: A226/B341,  
Oshiwara Industrial Centre,  
New Link Road,  
Goregaon(W)  
Mumbai 400104  
India  
[Tel:+91-22-67101229/28766205](tel:+91-22-67101229/28766205)  
H/P: +91-9821097101  
Email:[karco@karcoservices.com](mailto:karco@karcoservices.com)  
[www.karco.in](http://www.karco.in)

## ■ IMO/ILO/WHO references (R)

- R1 SOLAS (*Consolidated Edition, 2009*) Code IE110E ISBN 978-92-801-150
- R2 ILO/IMO/WHO INTERNATIONAL MEDICAL GUIDE FOR SHIPS (*3rd Edition*) Code I115E ISBN 978-92-415-47208
- R3 INTERNATIONAL SHIP ANDPORT FACILITY SECURITY CODE (ISPS Code) (*2003 Edition*) Code I116E ISBN 978-92-801-51497
- R4 INTERNATIONAL SAFETY MANAGEMENT CODE (ISM Code) AND GUIDELINES ON IMPLEMENTATION OF THE ISM CODE (*2010 Edition*) Code IB117E ISBN 978-92-801-51510
- R5 CODE OF THE INTERNATIONAL STANDARDS AND RECOMMENDED PRACTICES FOR A SAFETY INVESTIGATION INTO A MARINE CASUALTY OR MARINE INCIDENT (Casualty Investigation Code) (*2008 Edition*) Code I128E ISBN 978-92-801-14980

- R6 INTERNATIONAL CODE FOR FIRE SAFETY SYSTEMS (FSS Code) (2007 Edition) Code IA155E ISBN 978-92-801-14812
- R7 INTERNATIONAL CODE OF SAFETY FOR HIGH-SPEED CRAFT, 2000 (2000 HSC Code) (2008 Edition) Code IA185E ISBN 978-92-801-42402
- R8 INTERNATIONAL MARITIME DANGEROUS GOODS CODE (IMDG Code) 2008 Edition (incorporating amendment 34-08) Code IG200E ISBN 978-92-801-42419
- R9 GUIDELINES ON THE ENHANCED PROGRAMME OF INSPECTIONS DURING SURVEYS OF BULK CARRIERS AND OIL TANKERS (2008 Edition) Code IA265E ISBN 978-92-801-14966
- R10 INTERNATIONAL CONVENTION FOR SAFE CONTAINERS, 1972 (CSC 1972) (1996 Edition) Code IA282E ISBN 978-92-801-14119
- R11 CONVENTION ON FACILITATION OF INTERNATIONAL MARITIME TRAFFIC, 1965 (FAL 1965) (2006 Edition) Code IB350E ISBN 978-92-801-14676
- R12 INTERNATIONAL CONVENTION RELATING TO INTERVENTION ON THE HIGH SEAS IN CASES OF OIL POLLUTION CASUALTIES (Intervention), 1969 (1977 Edition) Code I402E ISBN 978-92-801-10708
- R13 INTERNATIONAL CONVENTION ON CIVIL LIABILITY FOR OIL POLLUTION DAMAGE, 1969 (CLC 1969) (1977 Edition) Code I410E ISBN 978-92-801-10713
- R14 CONFERENCE ON THE ESTABLISHMENT OF AN INTERNATIONAL COMPENSATION FUND FOR OIL POLLUTION DAMAGE, 1971 (1972 Edition) Code I420B (E/F) ISBN 978-92-801-11965
- R15 OFFICIAL RECORDS OF THE CONFERENCE ON THE ESTABLISHMENT OF AN INTERNATIONAL COMPENSATION FUND FOR OIL POLLUTION DAMAGE, 1971 (1978 Edition) Code I423E ISBN 978-92-801-10760
- R16 INTERNATIONAL LEGAL CONFERENCE ON MARITIME CARRIAGE OF NUCLEAR SUBSTANCES, 1971 (1972 Edition) Code I429B (E/F) ISBN 978-92-801-00174
- R17 ATHENS CONVENTION RELATING TO THE CARRIAGE OF PASSENGERS AND THEIR LUGGAGE BY SEA, 1974 (PAL 1974) (2003 Edition) Code IA436E ISBN 978-92-801-41610
- R18 INTERNATIONAL CONFERENCE ON LIMITATION OF LIABILITY FOR MARITIME CLAIMS, 1976 (2007 Edition) Code IA444E ISBN 978-92-801-14768
- R19 INTERNATIONAL CONFERENCE ON SALVAGE, 1989 (1989 Edition) Code I450E ISBN 978-92-801-12511
- R20 OFFICIAL RECORDS OF THE INTERNATIONAL CONFERENCE ON LIMITATION OF LIABILITY FOR MARITIME CLAIMS, 1976 (1983 Edition) Code I448E ISBN 978-92-801-11569
- R21 INTERNATIONAL CONFERENCE ON THE SUPPRESSION OF UNLAWFUL ACTS AGAINST THE SAFETY OF MARITIME NAVIGATION, 1988 (2006 Edition) Code IA462E ISBN 978-92-801-42297

- R22 CIVIL LIABILITY FOR OIL POLLUTION DAMAGE (*1996 Edition*) Code I473E ISBN 978-92-801-13310
- R23 INTERNATIONAL CONVENTION ON LIABILITY AND COMPENSATION FOR DAMAGE IN CONNECTION WITH THE CARRIAGE OF HAZARDOUS AND NOXIOUS SUBSTANCES BY SEA, 1996 (HNS Convention) (*1996 Edition*) Code I479E ISBN 978-92-801-14508
- R24 INTERNATIONAL CONVENTION ON CIVIL LIABILITY FOR BUNKER OIL POLLUTION DAMAGE, 2001 (*2004 Edition*) Code I490M ISBN 978-92-801-00327
- R25 MARPOL (*Consolidated Edition, 2006*) Code IC520E ISBN 978-92-801-42167
- R26 MARPOL – HOW TO DO IT (*2002 Edition*) Code IA636E ISBN 978-92-801-41528
- R27 POLLUTION PREVENTION EQUIPMENT UNDER MARPOL (*2006 Edition*) Code IA646E ISBN 978-92-801-14706
- R28 CONDITION ASSESSMENT SCHEME (CAS) (*2006 Edition*) Code I530E ISBN 978-92-801-42075
- R29 GUIDELINES FOR THE IMPLEMENTATION OF ANNEX V OF MARPOL (*2006 Edition*) Code IA656E ISBN 978-92-801-42235
- R30 PROVISIONS CONCERNING THE REPORTING OF INCIDENTS INVOLVING HARMFUL SUBSTANCES UNDER MARPOL (*1999 Edition*) Code IA516E ISBN 978-92-801-60987
- R31 LONDON CONVENTION 1972 AND 1996 PROTOCOL (*2003 Edition*) Code IA532E ISBN 978-92-801-41559
- R32 GUIDELINES ON THE CONVENTION ON THE PREVENTION OF MARINE POLLUTION BY DUMPING OF WASTES AND OTHER MATTER, 1972 (*2006 Edition*) Code I531E ISBN 978-92-801-51503
- R33 INTERNATIONAL CONVENTION ON OIL POLLUTION PREPAREDNESS, RESPONSE AND CO-OPERATION, 1990 (OPRC) (*1991 Edition*) Code I550E ISBN 978-92-801-12672
- R34 OPRC-HNS PROTOCOL 2000 (*2002 Edition*) Code I556E ISBN 978-92-801-51367
- R35 IMO/UNEP GUIDELINES ON OIL SPILL DISPERSANT APPLICATION INCLUDING ENVIRONMENTAL CONSIDERATIONS (*1995 Edition*) Code IA575E ISBN 978-92-801-13327
- R36 IMO/UNEP GUIDANCE MANUAL ON THE ASSESSMENT & RESTORATION OF ENVIRONMENTAL DAMAGE FOLLOWING MARINE OIL SPILLS (*2009 Edition*) Code I580E ISBN 978-92-801-15017
- R37 GUIDELINES FOR THE DEVELOPMENT OF SHIPBOARD MARINE POLLUTION EMERGENCY PLANS (*2010 Edition*) Code IB586E ISBN 978-92-801-15185
- R38 CRUDE OIL WASHING SYSTEMS (*2000 Edition*) Code IA617E ISBN 978-92-801-50940
- R39 BALLAST WATER MANAGEMENT CONVENTION (*2004 Edition*) Code I620M ISBN 978-92-801-00334

- R40 BALLAST WATER MANAGEMENT CONVENTION AND THE GUIDELINES FOR ITS IMPLEMENTATION (2009 Edition) Code I621E ISBN 978-92-801-15031
- R41 BUNKERS SAMPLING GUIDELINES (2005 Edition) Code I665E ISBN 978-92-801-41993
- R42 PROCEDURES FOR PORT STATE CONTROL (2000 Edition) Code IA650E ISBN 978-92-801-50995
- R43 INTERNATIONAL CONVENTION ON THE CONTROL OF HARMFUL ANTI-FOULING SYSTEMS (AFS) ON SHIPS, 2001 (2005 Edition) Code IA680E ISBN 978-92-801-41955
- R44 INTERNATIONAL CONFERENCE ON LOAD LINES, 1966 (2005 Edition) Code IB701E ISBN 978-92-801-41948
- R45 INTERNATIONAL CONFERENCE ON TONNAGE MEASUREMENT OF SHIPS, 1969 (1970 Edition) Code I713E ISBN 978-92-801-10906
- R46 INTERNATIONAL CODE FOR THE CONSTRUCTION AND EQUIPMENT OF SHIPS CARRYING DANGEROUS CHEMICALS IN BULK (IBC Code) (2007 Edition) Code IC100E ISBN 978-92-801-42266
- R47 CODE FOR THE CONSTRUCTION AND EQUIPMENT OF SHIPS CARRYING DANGEROUS CHEMICALS IN BULK (BCH Code) (2009 Edition) Code IC772E ISBN 978-92-801-15093
- R48 INTERNATIONAL CODE FOR THE CONSTRUCTION AND EQUIPMENT OF SHIPS CARRYING LIQUEFIED GASES IN BULK (IGC Code) (1993 Edition) Code I104E ISBN 978-92-801-12771
- R49 CODE FOR THE CONSTRUCTION AND EQUIPMENT OF SHIPS CARRYING LIQUEFIED GASES IN BULK (GC Code) (1983 Edition) Code I782E ISBN 978-92-801-11651
- R50 NOISE LEVELS ON BOARD SHIPS (1982 Edition) Code I814E ISBN 978-92-801-11347
- R51 INTERNATIONAL CODE FOR APPLICATION OF FIRE TEST PROCEDURES (FTP Code) (1998 Edition) Code IB844E ISBN 978-92-801-145
- R52 GUIDELINES ON SURVEYS REQUIRED BY THE 1978 SOLAS PROTOCOL, THE IBC CODE AND THE IGC CODE (1987 Edition) Code I858E ISBN 978-92-801-12221
- R53 CODE ON ALARMS AND INDICATORS, 1995 (1996 Edition) Code IA867E ISBN 978-92-801-14218
- R54 INTERNATIONAL CODE ON INTACT STABILITY, 2008 (2009 Edition) Code IB874E ISBN 978-92-801-15062
- R55 PREVENTION OF CORROSION ON BOARD SHIPS (2010 Edition) Code I877M ISBN 978-92-801-00358
- R56 CONVENTION ON THE INTERNATIONAL REGULATIONS FOR PREVENTING COLLISIONS AT SEA, 1972 (COLREG 1972) (Consolidated Edition 2003) Code IB904E ISBN 978-92-801-41672
- R57 INTERNATIONAL CONVENTION ON STANDARDS OF TRAINING, CERTIFICATION AND WATCHKEEPING FOR SEAFARERS, 1978 (STCW 1978) (2001 Edition) Code IB938E ISBN 978-92-801-51084
- R58 INTERNATIONAL CONVENTION ON SEARCH AND RESCUE, 1979 (SAR 1979) (2006 Edition) Code IB955E ISBN 978-92-801-52067

- R59 GUIDELINES ON FATIGUE (2002 Edition) Code I968E ISBN 978-92-801-51282
- R60 IMO/ILO GUIDELINES FOR THE DEVELOPMENT OF TABLES OF SEAFARERS' SHIPBOARD WORKING ARRANGEMENTS AND FORMATS OF RECORDS OF SEAFARERS' HOURS OF WORK OR HOURS OF REST (1999 Edition) Code I973E ISBN 978-92-801-60956
- R61 INTERNATIONAL LIFE-SAVING APPLIANCES CODE (LSA Code) (2010 edition) Code ID982E ISBN 978-92-801-15079
- R62 ASSEMBLY RESOLUTIONS on CD, Version 9 (2010) Code D026E ISBN 978-92-801-70320
- R63 INTERNATIONAL HEALTH REGULATIONS (2005).SECOND EDITION (GENEVA, WORLD HEALTH ORGANIZATION, 2008), ISBN 9789241580410
- R64 COMPENDIUM OF MARITIME LABOUR INSTRUMENTS (2008 EDITION) (INTERNATIONAL LABOUR OFFICE, GENEVA) ISBN 978-92-2-120612-5

Details of distributors of IMO/ILO/WHO publications that maintain a permanent stock of all IMO/ILO/WHO publications may be found on the IMO/ILO/WHO web site at <http://www.imo.org>; <http://www.ilo.org>; and <http://www.who.int>

## ■ Textbooks (T)

- T1 REED'S VOLUME 2: APPLIED MECHANICS FOR ENGINEERS; BY WILLIAM EMBLETON; REVISED BY J. T. GUNN; PUBLISHER: SUNDERLAND [TYNE AND WEAR]: THOMAS REED, 1983; ISBN: 0900335874
- T2 REED'S 3: APPLIED HEAT FOR ENGINEERS; EMBLETON, WILLIAM AND JACKSON, LESLIE;
- T3 REED'S VOLUME 4: NAVAL ARCHITECTURE FOR MARINE ENGINEERS; E. A. STOKOE; ISBN: 9780947637859
- T4 REED'S VOLUME 5: SHIP CONSTRUCTION FOR MARINE STUDENTS, E.A. STOKOE; ISBN 9780713671780
- T5 REED'S VOLUME 6: BASIC ELECTROTECHNOLOGY FOR ENGINEERS; E. G. R. KRAAL, PUBLISHER: LONDON: THOMAS REED PUBLICATIONS, [1985] ISBN: 0900335963
- T6 REED'S VOLUME 7: ADVANCED ELECTROTECHNOLOGY FOR ENGINEERS. 2ND ED.; KRAAL, E.G.R. LONDON, ADLARD COLES NAUTICAL, 2008
- T7 REED'S VOLUME 8: GENERAL ENGINEERING KNOWLEDGE FOR MARINE ENGINEERS; JACKSON & MORTON; A & C BLACK PUBLISHERS LTD (UNITED KINGDOM), 2006; ISBN 9780713682649
- T8 REED'S VOLUME 9: STEAM ENGINEERING KNOWLEDGE FOR MARINE ENGINEERS; BY THOMAS D. MORTON; PUBLISHER: LONDON: THOMAS REED PUBLICATIONS, 1979; ISBN: 0900335580
- T9 REED'S VOLUME 10: INSTRUMENTATION AND CONTROL SYSTEMS (REED'S MARINE ENGINEERING SERIES) LESLIE JACKSON; PUBLISHER: THOMAS REED PUBLICATIONS; ISBN: 0947637869 EDITION: PAPERBACK; 2002-12-07



- T10 REED'S VOLUME 12: MOTOR ENGINEERING KNOWLEDGE FOR MARINE ENGINEERS; BY THOMAS D. MORTON; TECHNICAL EDITOR, WILLIAM EMBLETON; PUBLISHER: SUNDERLAND: T. REED, 1978; ISBN: 0900335521
- T11 GENERAL ENGINEERING KNOWLEDGE; H D MCGEORGE; BUTTERWORTH-HEINEMANN; ISBN: 0750600063
- T12 MODERN MARINE ENGINEER'S MANUAL VOL 1; ALAN OSBOURNE AND A. BAYNE NIELD; CORNELL MARITIME PRESS, ISBN: 978-0870330636
- T13 MODERN MARINE ENGINEER'S MANUAL VOL 2; A. OSBOURNE AND E. C. HUNT; ISBN: 9780870335372
- T14 PRACTICAL MARINE ELECTRICAL KNOWLEDGE; DENNIS T. HALL; LONDON, WITHERBY & CO., (ISBN 1 85609 182 1)
- T15 THE RUNNING AND MAINTENANCE OF MARINE MACHINERY; EDITED BY J. COWLEY; PUBLISHER: LONDON: INSTITUTE OF MARINE ENGINEERS, 1992; ISBN: 0907206425
- T16 DERRETT, D.R SHIP STABILITY FOR MASTERS AND MATES, 6TH ED. BUTTEWORTH HEINEMANN, 2006 (ISBN 9870750667845)
- T17 APPLIED MECHANICS, J. HANNAH AND M. J. HILLIER, LONGMAN, 1998, ISBN 9780582256323
- T18 BASIC ENGINEERING THERMODYNAMICS; JOEL RAYNER; LONGMAN; ISBN0582256291;
- T19 MERCHANT SHIP CONSTRUCTION; D. A. TAYLOR; INSTITUTE OF MARINE ENGINEERS; ISBN 1 902536002
- T20 MARINE MEDIUM SPEED DIESEL ENGINES; DR. DENIS GRIFFITHS, INSTITUTE OF MARINE ENGINEERS; ISBN 1 902536185
- T21 MARINE LOW SPEED DIESEL ENGINES; DR. DENIS GRIFFITHS, INSTITUTE OF MARINE ENGINEERS; ISBN 090097679 9
- T22 POUNDER'S MARINE DIESEL ENGINES AND GAS TURBINES; DOUG WOODYARD; BUTTERWORTH HEINEMANN; ISBN: 978-0-7506-5846-1;
- T23 MARINE ELECTRICAL EQUIPMENT AND PRACTICE; H D McGEORGE; BUTTERWORTH-HEINEMANN; ISBN: 978-0750616478
- T24 CODE OF SAFE WORKING PRACTICES FOR MERCHANT SEAMEN CONSOLIDATED EDITION, 2010; THE STATIONERY OFFICE, UK; ISBN-978-0-11-553170-5
- T25 SHIP CONSTRUCTION; EYRES, D.J.; LONDON, BUTTERWORTH-HEINEMANN; ISBN: 0-7506-4887-2
- T26 MARITIME LAW; HILL, C.; LLOYD'S OF LONDON PRESS; ISBN: 1-850-44-888-4
- T27 INTERNATIONAL MEDICAL GUIDE FOR SHIPS. WORLD HEALTH ORGANIZATION
- T28 STABILITY AND TRIM FOR THE SHIP'S OFFICER; LA DAGE, J. AND VAN GEMERT, L. (EDS). ; CENTREVILLE, MARYLAND, US, CORNELL MARITIME PRESS; ISBN: 0-87033-297-X
- T29 SHIP CAPTAIN'S MEDICAL GUIDE. 1985. DEPARTMENT OF TRANSPORT HMSO PUBLISHED BY HMSO

- T30 THE SHIPMASTER'S BUSINESS COMPANION (BOOK AND CD); MACLACHLAN, MALCOLM; ISBN: 978 1 870077453
- T31 DIGITAL ELECTRONICS: PRINCIPLES AND APPLICATION; ROGER L TOKHEIM; MCGRAW-HILL; ISBN: 978-0078309823
- T32 POWER ELECTRONICS: CONVERTERS, APPLICATIONS, AND DESIGN; MOHAN, UNDELAND & RIOBBINS, JOHN WILEY & SONS; ISBN: 978-0-471-22693-2
- T33 MERCHANT SHIP CONSTRUCTION; H. J. PURSEY; FERGUSON BROWN & SON; ISBN 9870851744544
- T34 SHIPS & NAVAL ARCHITECTURE; MUNRO-SMITH, R.; INSTITUTE OF MARINE ENGINEERS; ISBN 9781902536169
- T35 SHIP DESIGN AND CONSTRUCTION, R. TAGGART, 1980, SNAME, NEW YORK; ISBN 0960304800
- T36 DRY-DOCKING & SHIPBOARD MAINTENANCE: A GUIDE TO INDUSTRY; DAVID J HOUSE; WITHERBY; ISBN: 978-1856092456
- T37 LAMB'S QUESTIONS & ANSWERS ON THE MARINE DIESEL ENGINE 8TH ED.; CHRISTENSEN, STANLEY G; BUTTERWORTH HEINEMANN; ISBN: 978-0-85264-307-5
- T38 MARINE STEAM BOILERS; MILTON AND REACH; BUTTERWORTH-HEINEMANN; ISBN: 978-0408004169
- T39 GUIDELINES ON THE APPLICATION OF THE IMO INTERNATIONAL SAFETY MANAGEMENT (ISM); ICS/ISF PUBLICATIONS
- T40 DIESEL MOTOR SHIPS ENGINES AND MACHINERY; CHRISTEN KNAK; G. E. C. GAD; ISBN: 978-8712467779
- T41 INTERNAL COMBUSTION ENGINE FUNDAMENTALS; J. B. HEYWOOD; MCGRAW-HILL SCIENCE; ISBN: 978-0070286375
- T42 MARINE BOILERS; G. T. H. FLANAGAN; ELSEVIER BUTTERWORTH-HEINEMANN; ISBN: 0750618213
- T43 APPLIED MECHANICS; D. TITHERINTON AND J. G. RIMMER; MCGRAW HILL; ISBN: 007084659-6
- T44 MATERIALS FOR MARINE MACHINERY, S. H. FREDERICK AND H. CAPPER; INSTITUTE OF MARINE ENGINEERS; ISBN: 0900976-42-X
- T45 FEED WATER SYSTEMS AND TREATMENT; G. T. H. FLANAGAN; STANFORD MARITIME; ISBN: 0540073431
- T46 APPLICATION OF AUTOMATIC MACHINERY AND ALARM EQUIPMENT IN SHIPS; R. G. SMITH; INSTITUTE OF MARINE ENGINEERS; ISBN: 0900976152
- T47 MARINE CONTROL PRACTICE; D. A. TAYLOR AND BILLIS; BUTTERWORTH-HEINEMANN; ISBN: 978-0408013130
- T48 PRINCIPLES OF REFRIGERATION; ROY J. DOSSAT; PRENTICE HALL; ISBN: 978-0130272706
- T49 MARINE REFRIGERATION & AIR CONDITIONING; JAMES HARBACH; CORNELL MARITIME PRESS; ISBN: 978-0870335655
- T50 HYDRAULICS AND PNEUMATICS; ANDREW PARR; BUTTERWORTH-HEINEMANN; ISBN: 978-0750644198
- T51 DIGITAL ELECTRONICS: PRINCIPLES, DEVICES AND APPLICATIONS; ANIL K. MAINI; WILEY; ISBN: 978-0470032145
- T52 PROGRAMMABLE LOGIC CONTROLLERS; W. BOLTON; NEWNES: ISBN: 978-0750681124

- T53 FABRICATION AND WELDING ENGINEERING; ROGER TIMINGS; NEWNES; ISBN: 978-0-7506-6691-6
- T54 INTRODUCTION TO PHYSICAL METALLURGY; SYDNEY H. AVNER; GLENCOE/MCGRAW-HILL; ISBN: 978-0070024991
- T55 ELECTRICAL EQUIPMENT HANDBOOK: TROUBLESHOOTING AND MAINTENANCE; PHILIP KIAMEH; MCGRAW-HILL PROFESSIONAL; ISBN: 978-0071396035
- T56 ELECTRIC CIRCUITS AND MACHINES; EUGENE LISTER, ROBERT RUSCH; MCGRAW-HILL; ISBN: 9780028018096
- T57 PRACTICAL NO-DESTRUCTIVE TESTING; BALDEV RAJ, T. JAYAKUMAR, M. THAVASIMUTHU; WOODHEAD PUBLISHING; ISBN: 1-855736004
- T-58 ELECTRICAL INTERFERENCE HANDBOOK, SECOND EDITION, NORMAN ELLIS, PUBLISHER: NEWNES, ISBN-10: 9780750635479
- T-59 ROGET'S INTERNATIONAL THESAURUS; PETER MARK ROGET; OXFORD & IBH PUBLISHING COMPANY PVT. LTD., 113 – B SHAHAPUR JAT, ASIAN VILLAGE SIDE, NEW DELHI 110 049; ISBN 978 – 81 – 204 – 1696 – 3
- T-60 THE INSULATED GATE BIPOLAR TRANSISTOR: IGBT THEORY AND DESIGN; VINOD KUMAR KHANNA; A JOHN WILEY & SONS, INC., PUBLICATION; ISBN 0-470-23845-7
- T-61 INTEGRATED SMART SENSORS: DESIGN AND CALIBRATION; GERT VAN DER HORN, JOHAN H. HUIJSING; KULWER ACADEMIC PUBLISHERS, 3300 AA DORDRECHT, THE NETHERLANDS; ISBN 0-7923-8004-5
- T-62 THE MICROCONTROLLER IDEA BOOK: CIRCUITS, PROGRAMS, & APPLICATIONS FEATURING; JAN AXELSON. LAKEVIEW RESEARCH, USA; ISBN 0-9650819-0-7
- T-63 INTRODUCTION TO MARINE GAS TURBINES, NAVAL EDUCATION AND TRAINING SUPPORT COMMAND, UNITED STATES GOVT. PRINTING OFFICE, WASHINGTON, D.C.

## ■ Bibliography (B)

- B1. ANDERSON, P. – ISM CODE: A GUIDE TO THE LEGAL AND INSURANCE IMPLICATIONS. LONDON, LLOYD'S OF LONDON PRESS. (ISBN 1-859-786-21-9)
- B2. ARROYO, D.W. - INTERNATIONAL MARITIME CONVENTIONS. DEVENTER (NETHERLANDS), KLUWER LAW AND TAXATION PUBLISHERS, 1991. (ISBN 90-6544-4408)
- B3. BARRASS, C.B. – SHIP STABILITY: NOTES AND EXAMPLES. 3RD ED. OXFORD, BUTTERWORTH-HEINEMANN, 2001. (ISBN 0-7506-4850-3)
- B4. BAUGHEN, S. - SHIPPING LAW. LONDON: CAVENDISH PUBLISHING LTD, 1998. (ISBN 1-85941-313-7)
- B5. BENNET, H. – LAW OF MARINE INSURANCE. 2ND ED. OXFORD, OXFORD UNIVERSITY PRESS, 2006 (ISBN 0-19-927359-6)

- B6. BIRNIE, P. & BOYLE, A.E. - INTERNATIONAL LAW AND THE ENVIRONMENT. 2ND ED. OXFORD, OXFORD UNIVERSITY PRESS, 2002. (ISBN 0-19-8766553-3)
- B7. BROWN, E.D. - THE INTERNATIONAL LAW OF THE SEA. 2 VOLS. ALDERSHOT, DARTMOUTH PUBLISHING CO. LTD., 1994 (ISBN 1-85521-306-0)
- B8. BROWN, R. H. - MARINE INSURANCE. VOL. 1 - PRINCIPLES AND BASIC PRACTICE. 6TH ED. LONDON, WITHERBY & CO. LTD., 1999. (ISBN 1-85609-150-3)
- B9. BROWN, R. H. - MARINE INSURANCE. VOL. 3 - HULL PRACTICE. 2ND ED. 1992. (ISBN 0-948691-45-X).
- B10. BRUBAKER, D. - MARINE POLLUTION AND INTERNATIONAL LAW: PRINCIPLES AND PRACTICES. LONDON, BELHAVEN PRESS, 1993. (ISBN 1-85293-273-2)
- B11. BUNDOCK, M. - SHIPPING LAW HANDBOOK. 3<sup>RD</sup> ED. LONDON, LLOYD'S OF LONDON PRESS, 2003 (ISBN 1-84311-209-4)
- B12. CAMINOS, H. (ED.) - LAW OF THE SEA. ALDERSHOT : DARTMOUTH PUBLISHING CO., 2001 (ISBN : 1-84014-090-9)
- B13. CHEN, X. – LIMITATION OF LIABILITY FOR MARITIME CLAIMS. THE HAGUE, KLUWER LAW INTERNATIONAL, 2001. (ISBN 90-411-1598-6)
- B14. CHURCHILL, R. & LOWE, A. - LAW OF THE SEA. 3RD ED. MANCHESTER UNIVERSITY PRESS, 1989. (ISBN 0-7190-4381-6)
- B15. CURTIS, S. - THE LAW OF SHIPBUILDING CONTRACTS. 3RD ED. LONDON, LLOYD'S OF LONDON PRESS, 2002.
- B16. DAVIES, D. - COMMENCEMENT OF LAYTIME, 3RD. ED. LONDON, LLOYD'S OF LONDON PRESS, (ISBN 1-85978-196-9)
- B17. DAVIES, M. & DICKEY, A. - SHIPPING LAW. 3RD ED. SYDNEY, LAWBOOK CO. 2004 (ISBN 0-455-22081-6)
- B18. FAIRPLAY PUBLICATIONS - TONNAGE MEASUREMENT OF SHIPS. 2ND ED. COULSDON, (UK), FAIRPLAY PUBLICATIONS LTD, 1980. (ISBN 0-905045-03-3)
- B19. FISHER, A. / ECON, D. – PRINCIPLES OF MARINE INSURANCE. LONDON, CHARTERED INSURANCE INSTITUTE, 1999. (ISBN 1-85369-267-0)
- B20. FOGARTY, - MERCHANT SHIPPING LEGISLATION. 2ND ED. LONDON, LLOYD'S OF LONDON PRESS, 2004. (ISBN 1-84311-329-5)
- B21. FORSBERG, G. - SALVAGE FROM THE SEA. GLASGOW, BROWN, SON & FERGUSON LTD, 1977. (ISBN 0-71008698-9)
- B22. GAUCI, G. - OIL POLLUTION AT SEA: CIVIL LIABILITY AND COMPENSATION FOR DAMAGE. CHICHESTER (WEST SUSSEX): JOHN WILEY & SONS, 1997. (ISBN : 0-471-97066-2)
- B23. GOLD, E. - GARD HANDBOOK ON MARINE POLLUTION. 2ND ED. ARENDAL, (NORWAY), ASSURANCE FORENINGEN GARD, 1997. (ISBN 82-90344-11-2)

- B24. HAZELWOOD, S.J. - P & I CLUBS: LAW AND PRACTICE. 3RD ED. LONDON, LLOYD'S OF LONDON PRESS, 2000 (ISBN 1-85978-531-X)
- B25. HODGES, S & HILL C. – PRINCIPLES OF MARITIME LAW. LONDON, LLOYD'S OF LONDON PRESS, 2001. (ISBN 1-85978-998-6)
- B26. HODGES, S. - LAW OF MARINE INSURANCE. LONDON, CAVENDISH PUBLISHING LTD, 1996 (ISBN 1-85941-227-0)
- B27. HOPKINS, F.N. - BUSINESS AND LAW FOR THE SHIPMASTER. 7TH ED. GLASGOW (UK), BROWN, SON & FERGUSON LTD, 1989. (ISBN 0-85174537-7)
- B28. HOUSE, D.J. - MARINE SURVIVAL AND RESCUE SYSTEMS. 2<sup>ND</sup> ED. LONDON, WITHERBY & CO. LTD. 1997 (ISBN 1-85609-127-9)
- B29. HUDSON, N AND ALLEN, J. - MARINE CLAIMS HANDBOOK. 5TH ED. LONDON, LLOYD'S OF LONDON PRESS, 1996. (ISBN 1-85978-048-2)
- B30. INTERNATIONAL ASSOCIATION OF CLASSIFICATION SOCIETIES (IACS) - BULK CARRIERS: GUIDANCE AND INFORMATION TO SHIPOWNERS AND OPERATORS. LONDON : IACS, 1992
- B31. INTERNATIONAL ASSOCIATION OF CLASSIFICATION SOCIETIES (IACS) - BULK CARRIERS: GUIDELINES FOR SURVEYS, ASSESSMENT AND REPAIR OF HULL STRUCTURE. 3RD ED. LONDON : WITHERBY AND CO. LTD, 1995 (ISBN : 1-85609-135-X)
- B32. INTERNATIONAL ASSOCIATION OF CLASSIFICATION SOCIETIES (IACS) - BULK CARRIERS: HANDLE WITH CARE. LONDON, IACS, 1998.
- B33. INTERNATIONAL ASSOCIATION OF CLASSIFICATION SOCIETIES (IACS) – CONTAINER SHIPS: GUIDELINES FOR SURVEYS, ASSESSMENT AND REPAIR OF HULL STRUCTURES. LONDON, WITHERBY & CO. LTD, 2005. (ISBN 1-85609-296-8)
- B34. INTERNATIONAL ASSOCIATION OF CLASSIFICATION SOCIETIES (IACS) - GENERAL CARGO SHIPS: GUIDELINES FOR SURVEYS, ASSESSMENT AND REPAIR OF HULL STRUCTURE. LONDON, WITHERBY & CO. LTD, 1999 (ISBN 1-85609-189-9)
- B35. INTERNATIONAL ASSOCIATION OF CLASSIFICATION SOCIETIES (IACS) - GUIDELINES FOR COATINGS MAINTENANCE AND REPAIRS. LONDON, WITHERBY & CO. LTD., 2005. (ISBN 1-85609-308-5)
- B36. INTERNATIONAL ASSOCIATION OF DRY CARGO SHIPOWNERS (INTERCARGO) - BULK CARRIER CASUALTY REPORT 2005, THE PREVIOUS TEN YEARS (1996-2005) AND THE TRENDS. LONDON, INTERCARGO, 2006
- B37. INTERNATIONAL ASSOCIATION OF DRY CARGO SHIPOWNERS (INTERCARGO) - PORT STATE CONTROL: A GUIDE FOR SHIPS INVOLVED IN THE DRY BULK TRADES. LONDON, INTERCARGO, 2000
- B38. INTERNATIONAL ASSOCIATION OF DRY CARGO SHIPOWNERS (INTERCARGO) - BULK CARRIERS: GUIDELINES FOR SURVEYS, ASSESSMENT AND REPAIR OF HULL STRUCTURES. 2ND ED. LONDON, WITHERBY & CO. LTD, 2002 (ISBN 1-85609-223-2)

- B39. INTERNATIONAL ASSOCIATION OF INDEPENDENT TANKER OWNERS (INTERTANKO) – A GUIDE TO CRUDE OIL WASHING AND CARGO HEATING CRITERIA. OSLO, INTERTANKO, 2004.
- B40. INTERNATIONAL ASSOCIATION OF INDEPENDENT TANKER OWNERS (INTERTANKO) - A GUIDE FOR CORRECT ENTRIES IN THE OIL RECORD BOOK (PART I – MACHINERY SPACE OPERATIONS). REVISED EDITION. OSLO, INTERTANKO, 2006.
- B41. INTERNATIONAL ASSOCIATION OF INDEPENDENT TANKER OWNERS (INTERTANKO) – A GUIDE FOR VETTING INSPECTIONS. 3RD ED. OSLO : INTERTANKO, 1997
- B42. INTERNATIONAL ASSOCIATION OF INDEPENDENT TANKER OWNERS (INTERTANKO) – A GUIDE TO INTERNATIONAL ENVIRONMENTAL MANAGEMENT SYSTEMS (EMS). OSLO : INTERTANKO,
- B43. INTERNATIONAL ASSOCIATION OF INDEPENDENT TANKER OWNERS (INTERTANKO) – A GUIDE TO BUNKERING OF SHIPS FOR THE PURPOSES OF ANNEX VI TO MARPOL. OSLO, INTERTANKO, 2004.
- B44. INTERNATIONAL CHAMBER OF SHIPPING (ICS) – CONDITION EVALUATION AND MAINTENANCE OF TANKER STRUCTURE. LONDON, WITHERBY & CO. LTD., 1992. (ISBN 1-85609-039-6)
- B45. INTERNATIONAL CHAMBER OF SHIPPING (ICS) - INTERNATIONAL SAFETY GUIDE FOR OIL TANKERS AND TERMINALS (ISGOTT). 5TH ED LONDON, WITHERBY & CO. LTD., 2006 (ISBN 1-85609-291-7)
- B46. INTERNATIONAL CHAMBER OF SHIPPING (ICS) - SAFETY IN CHEMICAL TANKERS. LONDON, WITHERBY & CO. LTD., 1977.
- B47. INTERNATIONAL CHAMBER OF SHIPPING (ICS) - SAFETY IN LIQUEFIED GAS TANKERS. LONDON, WITHERBY & CO. LTD., 1980
- B48. INTERNATIONAL CHAMBER OF SHIPPING (ICS) - SAFETY IN OIL TANKERS. LONDON. WITHERBY & CO. LTD., 1978.
- B49. INTERNATIONAL CHAMBER OF SHIPPING (ICS) - SHIP SHORE SAFETY CHECKLIST FOR BULK CARRIERS. LONDON, ICS, 2000
- B50. INTERNATIONAL CHAMBER OF SHIPPING (ICS) - SHIPPING AND THE ENVIRONMENT: A CODE OF PRACTICE. 3RD. ED, LONDON, ICS, 1999.
- B51. INTERNATIONAL CHAMBER OF SHIPPING (ICS) - TANKER SAFETY GUIDE: CHEMICALS. 3RD. ED. LONDON, ICS, 2002. (ISBN 0-906270-04-9)
- B52. INTERNATIONAL CHAMBER OF SHIPPING (ICS) - TANKER SAFETY GUIDE: LIQUEFIED GAS. 2ND ED. LONDON, ICS, 1995. (ISBN 0-906270-03-0)
- B53. INTERNATIONAL CHAMBER OF SHIPPING (ICS) / OIL COMPANIES INTERNATIONAL MARINE FORUM (OCIMF) - PERIL AT SEA AND SALVAGE: A GUIDE FOR MASTERS. 5TH ED. LONDON, WITHERBY & CO. LTD., 1998. (ISBN 1- 5609-095-7)
- B54. INTERNATIONAL CHAMBER OF SHIPPING (ICS) / OIL COMPANIES INTERNATIONAL MARINE FORUM (OCIMF) - CLEAN SEAS GUIDE

- B55. FOR OIL TANKERS. 4TH ED. LONDON WITHERBY & CO. LTD., 1994 (ISBN 1-85609-058-2)
- B56. INTERNATIONAL CHAMBER OF SHIPPING (ICS) / OIL COMPANIES INTERNATIONAL MARINE FORUM (OCIMF) - GUIDANCE MANUAL FOR THE INSPECTION AND CONDITION ASSESSMENT OF TANKER STRUCTURES. LONDON, WITHERBY & CO. LTD., 1986. (ISBN 0-948691-11-5);
- B57. INTERNATIONAL CHAMBER OF SHIPPING ET AL - BULK CARRIER CHECKLISTS. LONDON, ICS, 1996
- B58. INTERNATIONAL ORGANIZATION FOR STANDARDIZATION (ISO) - SHIPS AND MARINE TECHNOLOGY: BULK CARRIERS: CONSTRUCTION QUALITY OF HULL STRUCTURE. GENEVA, ISO, 2000. (ISO 15401)
- B59. INTERNATIONAL ORGANIZATION FOR STANDARDIZATION (ISO) - SHIPS AND MARINE TECHNOLOGY: BULK CARRIERS: REPAIR QUALITY OF HULL STRUCTURE. GENEVA, ISO, 2000. (ISO 15402)
- B60. INTERNATIONAL SHIPPING FEDERATION (ISF) - ILO MARITIME LABOUR CONVENTION: A GUIDE FOR THE SHIPPING, LONDON, ISF, 2006
- B61. JACKSON, D. - ENFORCEMENT OF MARITIME CLAIMS. 4TH ED. LONDON, LLOYD'S OF LONDON PRESS, 2005. (ISBN 1-84311-424-0)
- B62. JERVIS, B. – REEDS MARINE INSURANCE. LONDON, ADLARD COLES NAUTICAL, 2005. (ISBN 0-7136-7396-6) ([HTTP://WWW.ADLARDCOLES.COM](http://www.adlardcoles.com))
- B63. LLOYD'S REGISTER OF SHIPPING - BULK CARRIERS - THE SAFETY ISSUES. LONDON : LLOYD'S REGISTER OF SHIPPING, 1991
- B64. LLOYD'S REGISTER OF SHIPPING - BULK CARRIERS: AN UPDATE (JANUARY 1996). LONDON : LLOYD'S REGISTER OF SHIPPING, 1996
- B65. LLOYD'S REGISTER OF SHIPPING - BULK CARRIERS: GUIDANCE TO OPERATORS ON THE INSPECTION OF CARGO HOLDS. LONDON : LLOYD'S REGISTER OF SHIPPING, 1991
- B66. LLOYD'S REGISTER OF SHIPPING - LLOYD'S REGISTER AND THE STANDARD. A MASTER'S GUIDE TO HATCH COVER MAINTENANCE. LONDON, WITHERBY & CO. LTD, 2002 (ISBN 1-85609-232-1)
- B67. LUX, J. (ED). - CLASSIFICATION SOCIETIES. LONDON, LLOYD'S OF LONDON PRESS, 1993. (ISBN 1-85044-491-9)
- B68. MANDARAKA-SHEPPARD, A. – MODERN ADMIRALTY LAW. LONDON, CAVENDISH PUBLISHING LTD, 2001. (ISBN 1-85941-531-8)
- B69. NAUTICAL INSTITUTE - IMPROVING SHIP OPERATIONAL DESIGN. LONDON, THE NAUTICAL INSTITUTE, 1998.
- B70. NAUTICAL INSTITUTE - MASTER'S ROLE IN COLLECTING EVIDENCE. LONDON, NAUTICAL INSTITUTE, 1989. (ISBN 1-870077-05-9)

- B71. NAUTICAL INSTITUTE - SAFE OPERATION OF BULKS CARRIERS. LONDON, NAUTICAL INSTITUTE, 1991.
- B72. NAUTICAL INSTITUTE - SEAWORTHINESS: THE MARINE AND THE MARITIME LA W SERIES NO. 3. LONDON, NAUTICAL INSTITUTE, 1992.
- B73. OIL COMPANIES INTERNATIONAL MARINE FORUM (OCIMF) - GUIDE ON MARINE TERMINAL FIRE PROTECTION AND EMERGENCY EVACUATION. LONDON, WITHERBY & CO. LTD., 1987. (ISBN 0-948691-30-1)
- B74. OIL COMPANIES INTERNATIONAL MARINE FORUM (OCIMF) - MARINE AND TERMINAL OPERATIONS SURVEY GUIDELINES. LONDON, WITHERBY & CO. LTD., 1994. (ISBN 1-85609-62-0)
- B75. OIL COMPANIES INTERNATIONAL MARINE FORUM (OCIMF) - OIL SPILL CONTINGENCY PLANNING: A BRIEF GUIDE. LONDON, WITHERBY & CO. LTD. 1990. (0-900886-40-4)
- B76. OIL COMPANIES INTERNATIONAL MARINE FORUM (OCIMF) - OIL SPILL FATE AND IMPACT ON THE MARINE ENVIRONMENT. LONDON, WITHERBY & CO. LTD., 1980. (ISBN 0-900-80086-49-8)
- B77. OIL COMPANIES INTERNATIONAL MARINE FORUM (OCIMF) - RECOMMENDATIONS FOR OIL TANKER MANIFOLDS AND ASSOCIATED EQUIPMENT. 4TH ED. LONDON, WITHERBY & CO. LTD., 1991. (ISBN 1-85609-017-5)
- B78. OIL COMPANIES INTERNATIONAL MARINE FORUM (OCIMF) - SAFETY GUIDE FOR TERMINALS HANDLING SHIPS CARRYING LIQUEFIED GASES IN BULK. 2ND ED. LONDON. WITHERBY & CO. LTD. 1993. (ISBN 1-85609-057-4)
- B79. OIL COMPANIES INTERNATIONAL MARINE FORUM (OCIMF) - VESSEL INSPECTION QUESTIONNAIRE FOR BULK OIL/CHEMICAL CARRIERS AND GAS CARRIERS – V.I.Q. 2ND ED. LONDON, WITHERBY & CO. LTD, 2000. ISBN 1-85609-200-3)
- B80. OIL COMPANIES INTERNATIONAL MARINE FORUM (OCIMF) / INTERNATIONAL TANKER OWNERS POLLUTION FEDERATION (ITOPF) - GUIDELINES FOR THE PREPARATION OF SHIPBOARD OIL SPILL CONTINGENCY PLANS. LONDON, WITHERBY & CO. LTD., 1990. (ISBN 1-85609-016-7)
- B81. OIL COMPANIES INTERNATIONAL MARINE FORUM (OCIMF) / SOCIETY OF INTERNATIONAL GAS TANKERS AND TERMINAL OPERATORS (SIGTTO) - INSPECTION GUIDELINES FOR SHIPS CARRYING LIQUEFIED GASES IN BULK. 2ND ED. LONDON: WITHERBY & CO. LTD, 1998. (ISBN :1-85609-139-2)
- B82. OIL COMPANIES INTERNATIONAL MARINE FORUM (OCIMF) / SOCIETY OF INTERNATIONAL GAS TANKERS AND TERMINAL OPERATORS (SIGTTO) - SHIP INFORMATION QUESTIONNAIRE FOR GAS CARRIERS. 2ND ED. LONDON, WITHERBY & CO. LTD, 1998 (ISBN 1-85609-138-4)
- B83. OZCAYIR, Z.O. - LIABILITY FOR OIL POLLUTION AND COLLISIONS. LONDON, LLOYD'S OF LONDON PRESS (ISBN 1-85978-179-9)
- B84. PAYNE & IVAMY - MARINE INSURANCE. 4TH ED. SEVEN OAKS (UK), BUTTERWORTH & CO. LTD, 1985. (ISBN 0-406-25313-7)



- B85. POLAND, S. ROTH, T. - GARD HANDBOOK ON P & I INSURANCE. 4TH ED. ARENDAL (NORWAY), ASSURANCEFORENINGEN GARD , 1996 (ISBN 82-90344-16-3)
- B86. REYNOLDS, M. - ARBITRATION. LONDON, LLOYD'S OF LONDON PRESS, 1995. (ISBN 1-85044-550-8)
- B87. RHIDIAN THOMAS, D. (ED) - MODERN LAW OF MARINE INSURANCE. VOL. 1. LONDON, LLOYD'S OF LONDON PRESS, 1996. (ISBN 1-85978-033-4)
- B88. RHIDIAN THOMAS, D. (ED) - MODERN LAW OF MARINE INSURANCE. VOL. 2. LONDON LLOYD'S OF LONDON PRESS, 2002. (ISBN 1-84311-120-9)
- B89. RICHARDSON, J. - THE HAGUE AND HAGUE-VISBY RULES. 4TH ED. LONDON: LLOYD'S OF LONDON PRESS, 1999. (LLOYD'S PRACTICAL SHIPPING GUIDES) (ISBN : 1-85978-180-2)
- B90. ROSE, F. – MARINE INSURANCE: LAW AND PRACTICE. INFORMA, 2004 (ISBN 1-8431-1247-7)
- B91. ROSES, F. - GENERAL AVERAGE: LAW AND PRACTICE. LONDON, LLOYD'S OF LONDON PRESS, 1997. (ISBN 1-85978-158-6)
- B92. SANDS, P. - PRINCIPLES OF INTERNATIONAL ENVIRONMENTAL LAW. 2ND. ED. CAMBRIDGE, CAMBRIDGE UNIVERSITY PRESS, 2003 (ISBN 0-521-81794-3)
- B93. SCHOENBAUM, T.J. - ADMIRALTY AND MARITIME LAW. 3RD. ED. ST. PAUL (MINN.) (USA), WEST PUBLISHING CO., 2001. (ISBN 0-314-02711-4)
- B94. SCHOFIELD, J. - LAYTIME AND DEMURRAGE. 5TH. ED. LONDON, LLOYD'S OF LONDON PRESS, 2005. (ISBN 1-84311- 419-4)
- B95. SOCIETY OF INTERNATIONAL GAS TANKER AND TERMINAL OPERATORS (SIGTTO) - CREW SAFETY STANDARDS AND TRAINING FOR LNG CARRIERS: ESSENTIAL BEST PRACTICES FOR THE INDUSTRY. LONDON, WITHERBY & CO.LTD, 2003 (ISBN 1-85609-257-7)
- B96. SOCIETY OF INTERNATIONAL GAS TANKER AND TERMINAL OPERATORS (SIGTTO) - LIQUEFIED GAS FIRE HAZARD MANAGEMENT. LONDON, WITHERBY & CO. LTD., 2004. (ISBN 1-85609-265-8)
- B97. SOCIETY OF INTERNATIONAL GAS TANKER AND TERMINAL OPERATORS (SIGTTO) - LIQUEFIED GAS CARRIERS: YOUR PERSONAL SAFETY GUIDE. LONDON, WITHERBY & CO. LTD, 2002 (ISBN 1-85609-217-8)
- B98. TANKER STRUCTURE CO-OPERATIVE FORUM - GUIDANCE MANUAL FOR TANKER STRUCTURES. LONDON, WITHERBY & CO, LTD, 1997. (ISBN 1-85609-093-0)
- B99. TANKER STRUCTURE CO-OPERATIVE FORUM / INTERNATIONAL ASSOCIATION OF CLASSIFICATION SOCIETIES (IACS). - GUIDELINES FOR THE INSPECTION AND MAINTENANCE OF DOUBLE HULL TANKER STRUCTURES. LONDON, WITHERBY & CO. LTD., 1995. (ISBN 1-85609-080-9)

- B100. TETLEY, W. - MARITIME LIENS AND CLAIMS. 2ND. ED. MONTREAL, INTERNATIONAL SHIPPING PUBLICATIONS, 1998. (ISBN 2-89451-227-9)
- B101. THE TANKER STRUCTURE CO-OPERATIVE FORUM - GUIDELINES FOR BALLAST TANK COATING SYSTEMS AND SURFACE PREPARATION. LONDON: WITHERBY & CO. LTD., 2002. (ISBN : 1-85609-214-3)
- B102. THOMAS, D.R. - MARITIME LIENS. ANDOVER (HANTS, UK), STEVENS, 1998. (ISBN 0-4216-0920-6)
- B103. TUPPER, E.C. - INTRODUCTION TO NAVAL ARCHITECTURE. BUTTERWORTH-HEINEMANN, 1996. (ISBN 0-75062-529-5)
- B104. WILFORD, M. ET AL - TIME CHARTERS. 5TH ED. LONDON, LLP PROFESSIONAL PUBLISHING, 2003. (ISBN 1-84311-210-8)
- B105. WITHERBY & CO. LTD. - CONDITION EVALUATION AND MAINTENANCE OF TANKER STRUCTURES. LONDON, WITHERBY & CO. LTD., 1992. (ISBN 1-85609-039-6)
- B106. WITHERBY SEAMANSHIP INTERNATIONAL - CHEMICAL TANKERS: A POCKET SAFETY GUIDE. LONDON, WITHERBYS PUBLISHING LTD., 2006 (ISBN - 1-85609-324-7)
- B107. WITHERBY SEAMANSHIP INTERNATIONAL - LNG: OPERATIONAL PRACTICE. LONDON, WITHERBYS PUBLISHING LTD., 2006 (ISBN - 1-85609-321-7)
- B108. MARINE ENGINEERING; EDITOR, ROY L. HARRINGTON; PUBLISHER: JERSEY CITY, NJ : SOCIETY OF NAVAL ARCHITECTS AND MARINE ENGINEERS, C1992.; ISBN: 0939773104
- B109. INTERNATIONAL SAFETY GUIDE FOR OIL TANKERS AND TERMINALS. 5TH ED. ICS/OCIMF. LONDON,WITHERBY & CO. LTD 2006 (ISBN 978-1856-092-913)
- B110. TANKER OPERATIONS. A HANDBOOK FOR THE SHIPS OFFICER 3RD ED., 1992; MORTON, G.S. (ISBN 0-87033-432-8)
- B111. LIQUEFIED GAS HANDLING PRINCIPLES ON SHIPS AND TERMINALS. 2<sup>ND</sup> ED.; MCGUIRE AND WHITE; LONDON, WITHERBY. 1996 (ISBN 1-8560-9087-6)
- B112. GUIDELINES FOR THE INSPECTION AND MAINTENANCE OF DOUBLE HULL TANKER STRUCTURES. OCIMF. LONDON, WITHERBY. 1995 (ISBN 1-8560-9090-9)
- B113. TRAINING AND ASSESSMENT ON BOARD. 3RD ED.; HOLDER, L.A.; LONDON, WITHERBY & CO LTD,2002 (ISBN 1 85609 228 3)
- B114. STEAM - ITS GENERATION AND USE; BABCOCK AND WILCOX PUBLICATION
- B115. DIESEL ENGINE REFERENCE BOOK; L. R. C. LILLY; BUTTERWORTH; ISBN: 0408004436
- B116. BASIC SHIP THEORY; K. J. RAWSON AND E. C. TUPPER; LONGMAN; ISBN: 978-0582219250
- B117. ASHRAE HANDBOOK; ASHRAE
- B118. PUMP HANDBOOK; EDITED BY KARASSIK, KRUTZCH, FRASER, MESSINA; MCGRAW-HILL; ISBN: 978-0-07-146044-6
- B119. PUMP OPERATION AND MAINTENANCE; HICKS; TATA MCGRAW HILL; ISBN: 9780070993495

- B120. BASIC SHIP PROPULSION; J. P. GHOSE AND R. P. GOKARN;  
ALLIED PUBLISHERS; ISBN: 81-7764-606-0
- B121. APPLIED MARINE HYDRAULICS; PERRY STUTMAN; CORNELL  
MARITIME PR/TIDEWATER PUB; ISBN: 978-0870333668
- B122. MARKS' STANDARD HANDBOOK FOR MECHANICAL ENGINEERS,  
EUGENE AVALLONE, THEODORE BAUMEISTER, ALI SADEGH;  
MCGRAW-HILL; ISBN: 0071428674
- B123. STANDARD HANDBOOK FOR ELECTRICAL ENGINEERS; DONALD  
G. FINK (AUTHOR), JOHN M. CARROLL; MCGRAW-HILL; ISBN: 978-  
0070209749.

Chief Engineer Officer and Second Engineer Officer

**Function 1:**

**Marine Engineering at the Management Level**

## PART B1: COURSE OUTLINE

Knowledge, understanding and proficiency		Total hours for each topic	Total hours for each subject area of Required performance
<b>Competence:</b>			
<b>1.1</b>	<b>MANAGE THE OPERATION OF PROPULSION PLANT MACHINERY</b>		
1.1.1	DESIGN FEATURES, AND OPERATIVE MECHANISM OF MARINE DIESEL ENGINE AND ASSOCIATED AUXILIARIES	35	
1.1.2	DESIGN FEATURES, AND OPERATIVE MECHANISM OF MARINE STEAM TURBINE AND ASSOCIATED AUXILIARIES	5	
1.1.3	DESIGN FEATURES, AND OPERATIVE MECHANISM OF MARINE GAS TURBINE AND ASSOCIATED AUXILIARIES	10	
1.1.4	DESIGN FEATURES, AND OPERATIVE MECHANISM OF MARINE STEAM BOILER AND ASSOCIATED AUXILIARIES	15	
1.1.5	DESIGN FEATURES, AND OPERATIVE MECHANISM OF PROPELLER SHAFT AND ASSOCIATED ANCILLARIES	10	
1.1.6	TECHNICAL COMMUNICATIONS FOR DESIGN	40	
1.1.7	MANAGE THE OPERATION OF STEAM PROPULSION PLANT MACHINERY <i>(Only for candidates seeking certification for ships with main propulsion plant operated by steam boilers and steam turbines)</i>		
	.1 Design features and operative mechanism of a Marine Steam Turbines and associated auxiliaries	30	
	.2 Design features and operative mechanism of Marine Steam Boiler and associated auxiliaries	35	
	.3 Propulsive characteristics of Steam Turbine	10	
	.4 The efficient operation, surveillance, performance assessment and maintaining safety of propulsion plant and auxiliary machinery.	10	200
<b>1.2</b>	<b>PLAN AND SCHEDULE OPERATIONS <i>Theoretical knowledge</i></b>		
1.2.1	THERMODYNAMICS AND HEAT TRANSMISSION		

<b>Knowledge, understanding and proficiency</b>		<b>Total hours for each topic</b>	<b>Total hours for each subject area of Required performance</b>
.1	Thermodynamic Fundamentals	6	
.2	Perfect Gas	12	
.3	Second Law	12	
.4	Gas Cycles/Engine Analysis	12	
.5	Properties of Vapours	6	
.6	Steam Cycles	9	
.7	Steam Turbine Velocity Diagrams	3	
.8	Refrigeration	6	
.9	Combustion	6	
.10	Compressors	3	
.11	Heat Transfer	12	
.12	Air Conditioning	3	90
<b>1.2.2</b>	<b>MECHANICS AND HYDROMECHANICS</b>		
.1	Statics	8	
.2	Dynamics	14	
.3	Friction	4	
.4	Balancing	4	
.5	Simple Harmonic Motion	6	
.6	Stress & Strain	10	
.7	Bending of Beams	12	
.8	Torsion	8	
.9	Struts	4	
.10	Combined Stress	4	
.11	Stresses in Thick Shells	4	
.12	Fluid Mechanics	12	90
<b>1.2.3</b>	<b>PROPULSIVE CHARACTERISTICS OF DIESEL ENGINES, STEAM AND GAS TURBINES, INCLUDING SPEED, OUTPUT AND FUEL CONSUMPTION</b>		
.1	Engine layout and load diagrams	7	7
<b>1.2.4</b>	<b>HEAT CYCLE, THERMAL EFFICIENCY AND HEAT BALANCE OF THE FOLLOWING</b>		
.1	Marine diesel engine	5	
.2	Marine steam boiler and steam turbine	10	
.3	Marine gas turbine	5	20

<b>1.2.5</b>	<b>REFREGIRATORS AND REFRIGERATION CYCLE</b>		
	.1 Refrigeration and Air conditioning system design, operation and maintenance	10	10
<b>1.2.6</b>	<b>PHYSICAL AND CHEMICAL PROPERTIES OF FUELS AND LUBRICANTS</b>		
	.1 Production of Oils from Crude Oil	1	
	.2 Properties and characteristics of fuels and lubricants	1	
	.3 Shore side and shipboard sampling and testing	1	
	.4 Interpretation of test results	1	
	.5 Contaminants including microbiological infection	2	
	.6 Treatments of fuels and lubricants including storage, centrifuging, blending, pretreatment and handling.	4	10
<b>1.2.7</b>	<b>TECHNOLOGY OF MATERIAL</b>		
	.1 Metallurgy of Steel and Cast Iron	1	
	.2 Properties and application of material used in machinery on board ships	2	
	.3 Destructive and non-destructive testing of material	3	
	.4 Engineering processes used in construction and repair	4	
	.5 Materials and welding	5	15
<b>1.2.8</b>	<b>NAVAL ARCHITECTURE AND SHIP CONSTRUCTION INCLUDING DAMAGE CONTROL</b> (Refer to 4.1.1 ), 4.1.2 and 4.1.3)		-
<b>1.3</b>	<b>OPERATION, SURVEILLANCE, PERFORMANCE ASSESSMENT AND MAINTAINING SAFETY OF PROPULSION PLANT AND AUXILIARY MACHINERY <i>Practical knowledge</i></b>		
<b>1.3.1</b>	<b>START UP AND SHUT DOWN MAIN AND AUXILIARY MACHINERY, INCLUDING ASSOCIATED SYSTEM</b>		
	.1 Engine components	18	
	.2 Engine Lubrication	8	
	.3 Fuel Injection	12	
	.4 Scavenging and Supercharging	10	
	.5 Starting and Reversing	8	
	.6 Cooling systems	4	
	.7 Diesel Engine Control and Safety	4	

.8	Diesel Engine Emergency operation	2	
.9	Multi-engine Propulsion Arrangement	2	
.10	Air compressors and compressed air systems	3	
.11	Hydraulic power system	6	
.12	Types of auxiliary boilers	9	
.13	Auxiliary steam system	2	
.14	Safety valves	4	
.15	Boiler water level indicators	6	
.16	Use of Sea water in Boilers	0.5	
.17	Use of Fresh Water in Boilers	0.5	
.18	Boiler Water Testing	3	
.19	Boiler Water Treatment	9	
.20	Auxiliary Steam turbines	9	
.21	Boiler defects	3	
.22	Boiler and steam turbine survey and repairs	6	
.23	Evaporators	6	
.24	Thermal fluid heating system	3	138
<b>1.3.2</b>	<b>OPERATING LIMITS OF PROPULSION PLANTS (Refer to 1.2.3 )</b>	-	-
<b>1.3.3</b>	<b>THE EFFICIENT OPERATION, SURVEILLANCE, PERFORMANCE ASSESSMENT AND MAINTAINING SAFETY OF PROPULSION PLANT AND AUXILIARY MACHINERY</b>		
.1	Diesel engines	10	10
<b>1.3.4</b>	<b>FUNCTIONS AND MECHANISM OF AUTOMATIC CONTROL FOR MAIN ENGINE (Refer to 2.1.2.2)</b>	-	-
<b>1.3.5</b>	<b>FUNCTIONS AND MECHANISM OF AUTOMATIC CONTROL FOR AUXILIARY MACHINERY:</b>		
.1	Generator distribution system (Refer to 2.1.2.3)	-	
.2	Steam boiler (Refer to 2.1.2.4)	-	
.3	Oil purifier	3	
.4	Refrigeration system	3	
.5	Pumping and piping system	1	
.6	Steering gear system	2	
.7	Cargo-handling equipment and deck machinery	1	10



## 1.4 MANAGE FUEL, LUBRICATION AND BALLAST OPERATIONS

### 1.4.1 OPERATION AND MAINTENANCE OF MACHINERY, INCLUDING PUMPS AND PUMPING SYSTEM

.1	Ballast	2	
.2	Bilge	2	
.3	Fire Main	2	
.4	Prevention of Pollution of the Sea by Oil	2	
.5	Sewage and sludge	2	10
<b>Total for Function 1: Marine Engineering at the management level</b>			<b>610</b>

## **Part C1: Detailed Teaching Syllabus**

### **COMPETENCE 1.1 MANAGE THE OPERATION OF PROPULSION PLANT MACHINERY**

#### **TRAINING OUTCOMES:**

Demonstrates a knowledge and understanding of:

#### **1.1 MANAGE THE OPERATION OF PROPULSION PLANT MACHINERY**

**1.1.1 DESIGN FEATURES, AND OPERATIVE MECHANISM OF MARINE DIESEL ENGINE AND ASSOCIATED AUXILIARIES**

**1.1.2 DESIGN FEATURES, AND OPERATIVE MECHANISM OF MARINE STEAM TURBINE AND ASSOCIATED AUXILIARIES**

**1.1.3 DESIGN FEATURES, AND OPERATIVE MECHANISM OF MARINE GAS TURBINE AND ASSOCIATED AUXILIARIES**

**1.1.4 DESIGN FEATURES, AND OPERATIVE MECHANISM OF MARINE STEAM BOILER AND ASSOCIATED AUXILIARIES**

**1.1.5 DESIGN FEATURES, AND OPERATIVE MECHANISM OF PROPELLER SHAFT AND ASSOCIATED ANCILLARIES**

**1.1.6 TECHNICAL COMMUNICATIONS FOR DESIGN**

**1.1.7 MANAGE THE OPERATION OF STEAM PROPULSION PLANT MACHINERY**



- Describes with the aid of sketches/computer aided drawing, material selection, and design features of the combustion chamber components of diesel engine:
  - Cylinder cover and mountings / excess pressure release method
  - Cooling of cylinder cover
  - Cylinder Liner and cooling arrangements
  - Piston crown
  - Piston assembly
  - Geometry of combustion chamber
  - Exhaust valve and cooling arrangement
  
- Describes with the aid of sketches/computer aided drawing, material selection, and design features of piston rings, compatibility to cylinder liner and cylinder lubrication employed in a diesel engine:
  - Cylinder liner material
  - Piston rings material
  - Manufacturing methods of cylinder liner
  - Manufacturing methods of piston rings
  - Types of cylinder lubrication and mechanism.
  - Selection of cylinder lubrication oil
  
- Describes with the aid of sketches the operative mechanism of diesel engine system
  - Starting and Reversing system
  - Cooling water system
  - Lubrication oil system
  - Fuel oil system
  - Scavenging, supercharging and exhausting.
  - Engine safety system
  - Engine emergency operating system

#### 1.1.2 DESIGN FEATURES AND OPERATIVE MECHANISM OF MARINE STEAM TURBINE AND ASSOCIATED AUXILIARIES

Required Performance:

.1 **Design features and operative mechanism of a Marine Steam Turbines and associated auxiliaries (5 hours)**

- Describes with the aid of sketches/computer aided drawing, material selection and design features of steam turbines:
  - Impulse and reaction turbines
  - Materials of blades and other components

- Turbine construction
- Bearings, thrust bearings
- Turbine glands and gland steam systems
- Describes with the aid of sketches the operative mechanism of steam turbines:
  - Alarms and trips.
  - Warming through.
  - Shut down procedures.
  - Sequential nozzle operation.
  - Vibration.

### 1.1.3 DESIGN FEATURES, AND OPERATIVE MECHANISM OF MARINE GAS TURBINE AND ASSOCIATED AUXILIARIES

Required Performance:

#### .1 Design features and operative mechanism of marine gas turbine and associated auxiliaries (10 hours)

- Describes with the aid of sketches/computer aided drawing, material selection and design features of gas turbines:
  - Analyse the flow of air and gas through a simple marine gas turbine.
  - Identify the materials and construction of a gas turbine compressor, combustion system, and turbine for single and two shaft design
  - Discuss the design features related to maintenance requirements associated with optimum performance of a marine gas turbine plant.
- Describes with the aid of sketches the operative mechanism of a Marine Gas Turbine:
  - Lubrication system
  - Fuel system
  - Starting system
  - Monitoring and control system
  - Other ancillary equipment.

### 1.1.4 DESIGN FEATURES AND OPERATIVE MECHANISM OF MARINE STEAM BOILER AND ASSOCIATED AUXILIARIES

Required Performance:

#### .1 Design features and operative mechanism of Marine Steam Boiler and associated auxiliaries (15 hours)

- Describes with the aid of sketches/computer aided drawing, material

selection and design features of marine steam boilers:

- Types of steam boilers.
  - Boiler fittings and drum internals.
  - Water circulation.
  - Gas circulation.
  - Operating parameters.
  - Support and expansion.
  - Soot blowers.
  - Economisers.
  - Burners and burner registers.
  - Local and remote water level indicators.
  - Safety valves.
- Describes with the aid of sketches/computer aided drawing, material selection and design features of marine steam boiler feed water systems:
- Condenser types, level control, construction, materials, support, expansion, operating parameters, loss of vacuum and leak testing.
  - Air ejectors.
  - Vacuum pumps.
  - Extraction pumps.
  - Drain coolers.

#### 1.1.5 DESIGN FEATURES, AND OPERATIVE MECHANISM OF PROPELLER SHAFT AND ASSOCIATED ANCILLARIES

Required Performance:

- .1 **Describes with the aid of sketches/computer aided drawing, material selection and design features of propeller shaft and associated ancillaries:**

**(10 hours)**

- Establishing the shaft centre line
- Deviation while building
- Alignment deviation in service
- Fair curve alignment
- Shaft checks
- Shaft bearings
  - ❖ Plain bearings
  - ❖ Tilting pad bearings
  - ❖ Roller bearings
- Coupling bolts
- Stern tubes
- Stern tube sealing arrangements
- Fixed pitch propellers

- Methods of mounting fixed pitch propellers
  - ❖ Keyed propellers
  - ❖ Keyless propellers
- Controllable pitch propellers
- Gears and clutches
- Reverse reduction gearbox
- Flexible couplings
- Air operated clutches

#### 1.1.6 TECHNICAL COMMUNICATIONS FOR DESIGN

Required Performance:

#### .1 Technical Communications for design (40 hours)

- Drawing
  - Working drawings of assemblies and components of marine machinery to demonstrate ability to apply the principles of projection through plan, elevation and sectional views in 1st and/or 3rd angle orthographic projection, using relevant international standards.
- Technical Literature
  - Use of general engineering terms and symbols and in particular those used in marine engineering
- Operations Manual
  - Interpretation of block, logic systems and flow diagrams applicable to marine machinery and systems.
  - Interpretation of general arrangements, systems and detail plans of ship structures, machinery and equipment.
- Drawing Environment
  - Set up snap grid, units, layers, line types and drawing limits.
  - Prototype drawing.
- Basic Techniques
  - Lines, circles, snap, objects snap, ortho snap, relative coordinates, polar coordinates, trim, extend, copy, mirror, array, chamfer, fillet, zoom and pan.
- 2D Drawing
  - Orthographic projection, assembly drawing
- Dimensioning and Annotating
  - Dimensioning and adding text to International Drawing Standards.

- Plotting
  - Paper size, plot scale, plot review, margins, line thickness.
- Use of Engineering Design and Mathematical Software

### 1.1.7 **MANAGE THE OPERATION OF STEAM PROPULSION PLANT MACHINERY**

Required Performance:

#### **.1 Design features and operative mechanism of a Marine Steam Turbines and associated auxiliaries (30 hours)**

- Describes with the aid of sketches/computer aided drawing, material selection and design features of steam turbines:
  - Convergent and convergent/divergent nozzles and Nozzle boxes
  - Impulse and reaction turbines
  - Pressure and velocity compounding
  - Pressure/velocity diagrams
  - Optimum blade speeds
  - Hybrid blades
  - Materials of blades and other components
  - Turbine construction
  - Erosion shields
  - Bearings, thrust bearings
  - Turbine glands and gland steam systems
  - Astern turbines
  - Turbine casings
  - Diaphragms
  - Reheat turbines
  - Support and expansion of turbines.
- Describes with the aid of sketches the operative mechanism of steam turbines:
  - Alarms and trips.
  - Warming through.
  - Normal and emergency operation.
  - Shut down procedures.
  - Turbine performance.
  - Sequential nozzle operation.
  - Resonance.
  - Critical speed.
  - Vibration.



- Emergency control systems.
- Rotor straightening.
- Describes with the aid of sketches/computer aided drawing, material selection and design features of steam turbine gear box:
  - Single and double reduction
  - Double helical involute gear teeth
  - Single and double locked gear trains
  - Epicyclic gearing
  - Flexible couplings
  - Nodal drive
  - Method of manufacturing of spur gears.

**.2 Design features and operative mechanism of Marine Steam Boiler and associated auxiliaries (35 hours)**

- Describes with the aid of sketches/computer aided drawing, material selection and design features of marine steam boilers:
  - Types of main steam boilers.
  - Methods of construction.
  - Boiler fittings and drum internals.
  - Water circulation.
  - Gas circulation.
  - Operating parameters.
  - Support and expansion.
  - Superheaters and their temperature control.
  - Soot blowers.
  - Economisers.
  - Air heaters.
  - Steam to steam generation.
  - Chemistry of combustion.
  - Burners and burner registers.
  - Local and remote water level indicators.
  - Safety valves.
- Describes with the aid of sketches/computer aided drawing, material selection and design features of marine steam boiler feed water systems:
  - Main feed systems.
  - Condenser types, level control, construction, materials, support, expansion, operating parameters, loss of vacuum and leak testing.
  - Air ejectors.
  - Vacuum pumps.
  - Extraction pumps.

- Gland condensers.
- Low pressure heaters.
- Drain coolers.
- High-pressure heaters.
- Turbo feed pumps, hydraulic balance.
- De-aerators.

**.3 Propulsive characteristics of Steam Turbine (10 hours)**

- Propeller curve
- Propeller design point
- Fouled hull, sea margin and heavy propeller
- Continuous service rating
- Limits for continuous operation
- Limits for overload operation
- Evaluate plant performance and analysis

**.4 The efficient operation, surveillance, performance assessment and maintaining safety of propulsion plant and auxiliary machinery (10 hours)**

- Performance data of individual turbines and cycle components during sea trial
- Periodic acquisition of above mentioned data and comparison for location of deterioration,
- Enthalpy drop test in superheated section of steam turbine
- Quantification of stage efficiency losses
  - Leakage
  - Friction
  - Aerodynamic
  - Changes in flow passage areas

**COMPETENCE 1.2 PLAN AND SCHEDULE OPERATIONS *Theoretical knowledge***

**TRAINING OUTCOMES:**

Demonstrates a knowledge and understanding of:

**1.2 PLAN AND SCHEDULE OPERATIONS *Theoretical knowledge***

1.2.1 THERMODYNAMICS AND, HEAT TRANSMISSION

1.2.2 MECHANICS AND HYDROMECHANICS

1.2.3 PROPULSIVE CHARACTERISTICS OF DIESEL ENGINES, STEAM AND GAS TURBINES, INCLUDING SPEED, OUTPUT AND FUEL CONSUMPTION

1.2.4 HEAT CYCLE, THERMAL EFFICIENCY AND HEAT BALANCE OF THE FOLLOWING

.1 Marine diesel engine

.2 Marine steam boiler and steam turbine

.3 Marine gas turbine

1.2.5 REFRIGERATORS AND REFRIGERATION CYCLE

1.2.6 PHYSICAL AND CHEMICAL PROPERTIES OF FUELS AND LUBRICANTS

1.2.7 TECHNOLOGY OF MATERIAL

1.2.8 NAVAL ARCHITECTURE AND SHIP CONSTRUCTION INCLUDING DAMAGE CONTROL

**COMPETENCE 1.2 PLAN AND SCHEDULE OPERATIONS** *Theoretical knowledge*

**1.2.1 THERMODYNAMICS AND HEAT TRANSMISSION**

Required Performance:

- .1 Thermodynamic Fundamentals ( 6 hours)**
- System and working substance
  - SI Units. Property and State
  - Reversible and Irreversible processes
  - Reversible work of compression or expansion
  - First Law applied to non-flow and flow processes.
  - Throttling, nozzles and mixing of streams.
- .2 Perfect Gas ( 12 hours )**
- Equation of state
  - Specific heat, internal energy.
  - Adiabatic, polytropic, isobaric and isothermal compression/expansion
  - Enthalpy
  - Gas mixtures and Daltons Law of partial pressures.
- .3 Second Law ( 12 hours)**
- Classical statements.
  - Heat engine.
  - Thermal efficiency.
  - Entropy
  - Isentropic process
  - Reversible heat engine
  - Temperature – entropy (T-s) diagram for a perfect gas
  - Isentropic efficiency.
- .4 Gas Cycles/Engine Analysis ( 12 hours)**
- Constant pressure and constant volume air standard cycles
  - Reciprocating internal combustion engine performance parameters: indicator diagrams, power, mean effective pressure, thermal efficiency, brake specific fuel consumption, mechanical efficiency, energy balance
  - Open and closed gas turbine systems
  - Power, isentropic efficiency and thermal efficiency for gas turbines.
- .5 Properties of Vapours ( 6 hours)**
- Saturation, dryness fraction and superheat
  - T-s, p-h, p-v, h-s diagrams

- Fluid properties using steam tables
- Throttling and separating calorimeters
- Air in condensers.

**.6 Steam Cycles ( 9 hours )**

- Rankine cycle. Turbine isentropic efficiency
- Feed heating
- Thermal efficiency
- Cycle on T-s diagram.

**.7 Steam Turbine Velocity Diagrams ( 3 hours )**

- Principles of reaction and impulse turbines including compounding
- Velocity diagrams
- Nozzle steam velocity (excluding proof of critical pressure ratios)
- Force and work done on blades.

**.8 Refrigeration ( 6 hours )**

- Vapour compression cycle
- Refrigerant properties and hazards
- Refrigerant tables
- Cycle on p-h diagram
- Coefficient of performance
- Refrigerant mass flow
- Compressor calculations
- Secondary refrigerants.

**.9 Combustion ( 6 hours )**

- Combustion equations
- Fuel composition
- Air-fuel ratio
- Excess air
- Volumetric analysis of combustion products
- Calorific value.

**.10 Compressors ( 3 hours )**

- Reciprocating compressors: Operating principles, volumetric efficiency, free air delivery, power, mechanical efficiency, isothermal efficiency, multi-stage and inter-cooling, p-V diagram
- Positive displacement rotary compressors: Operating principles, power, efficiency.

**.11 Heat Transfer ( 12 hours )**

- Conduction, radiation and convection

- Composite walls. Insulation
- Film coefficient
- Interface temperature
- Stefan-Boltzmann Law
- Parallel flow and cross flow heat exchangers
- Logarithmic mean temperature difference.

**.12 Air Conditioning ( 3 hours )**

- Comfort conditions
- Psychrometric charts
- Wet and dry bulb temperatures
- Humidity
- Dew point
- Dehumidifying and humidifying processes
- Air conditioning systems.

**1.2.2 MECHANICS AND HYDROMECHANICS**

Required Performance:

**.1 Statics (8 hours)**

- Bow's notation
- Force analysis by method of sections
- Framed structures.

**.2 Dynamics (14 hours)**

- Equations of motion
- Velocity and acceleration diagrams
- Laws of conservation of energy and momentum
- Collision of rigid and elastic bodies
- Projectiles
- Engine mechanisms
- Flywheels
- Hoists
- Cams
- Governors
- Simple and epicyclic gear systems
- Vehicle dynamics.

**.3 Friction (4 hours)**

- Sliding friction on horizontal and inclined planes
- Cotters
- Screw threads
- Belt drives

- Friction brakes
- Plate and cone clutches.

**.4 Balancing (4 hours)**

- Primary and secondary forces
- Primary and secondary couples
- Complete balancing of reciprocating machinery.

**.5 Simple Harmonic Motion (6 hours)**

- Equation of simple harmonic motion
- Amplitude, frequency and periodic time
- Vibrating spring mass systems
- Springs
- Resonance
- Transmissibility
- Vibrations of flywheels and gearwheels.

**.6 Stress & Strain (10 hours)**

- Stress and strain relationships in thin cylindrical and spherical shells
- Stress in thin, rotating rims
- Thermal stress
- Stress in compound bars
- Elastic strain energy
- Stresses due to gradually applied and shock loads.

**.7 Bending of Beam (12 hours)**

- Shear force and bending moment diagrams
- Fundamental bending equation
- Bending stresses
- Deflection of beams. Macaulay's method.

**.8 Torsion (8 hours)**

- Stress, strain and strain energy due to torsion
- Fundamental torsion equation
- Reciprocating engine crank effort
- Rudder stock turning moment from steering gear
- Deflection of helical springs.

**.9 Struts (4 hours)**

- Euler's formula
- Slenderness ratio

**.10 Combined Stress (4 hours)**

- Stresses on an oblique plane
- Material subjected to two perpendicular stresses
- Axial and bending stress
- Mohr's stress circle. Principal stresses and strains
- Combined bending and twisting.

**.11 Stresses In Thick Shells (4 hours)**

- Lamé's equations
- The Lamé Line
- Shrinkage allowance.

**.12 Fluid Mechanics (12 hours)**

- Volume and mass flow
- Venturi meter.
- Bernoulli's equation
- Jets. Orifice coefficients
- Dynamic and kinematic viscosity
- Reynolds' number
- Flow losses in pipes and fittings
- Darcy's formula
- Centrifugal pumps.

**1.2.3 PROPULSIVE CHARACTERISTICS OF DIESEL ENGINES INCLUDING SPEED, OUTPUT AND FUEL CONSUMPTION**

Required Performance:

**.1 Engine layout and load diagrams (7 hours)**

- Propeller curve
- Propeller design point
- Fouled hull, sea margin and heavy propeller
- Continuous service rating
- Engine margin
- Constant ship speed lines
- Limits for continuous operation
- Limits for overload operation
- Specific fuel oil consumption (SFOC)
- SFOC based on reference ambient conditions stated in ISO 3046/1-1986
- Adjustment of SFOC for lower calorific value of fuels and ambient conditions different from ISO reference conditions.



#### 1.2.4 HEAT CYCLE, THERMAL EFFICIENCY AND HEAT BALANCE OF THE FOLLOWING

Required Performance:

- .1 Marine diesel engine (5 hours)**
- Dual cycle
  - Thermal efficiency of dual cycle
  - Heat balance of marine diesel engine
- .2 Marine steam boiler and steam turbine (10 hours)**
- Rankine cycle
  - Thermal efficiency of Rankine cycle
  - Heat balance of a marine steam plant
- .3 Marine gas turbine (5 hours)**
- Brayton cycle
  - Thermal efficiency of Brayton cycle
  - Heat balance of marine gas turbine plant

#### 1.2.5 REFREGIRATORS AND REFRIGERATION CYCLE

Required Performance :

- .1 Refrigeration and Air Conditioning system (10 hours)**
- Assess common refrigerants used on board, using factors such as their properties, economics of use, handling, health hazards, and environmental impact
  - Explain the environmental concerns of traditional refrigerants and the methods used to address these concerns
  - Explain correct procedures for the recovery of refrigerants from refrigeration systems
  - Analyse functions and operation of all components including fittings and safety devices of refrigeration and air conditioning plants
  - Interpret symptoms, effects, and remedial actions for common faults in refrigeration and air conditioning systems
  - Precautions during cargo operations – re-circulation system of AHU
  - Explain the purposes and procedures for pumping down, leak test, refrigerant charging and oil changing
  - Record keeping of refrigerant consumption.

#### 1.2.6 PHYSICAL AND CHEMICAL PROPERTIES OF FUELS AND LUBRICANTS

Required Performance :

- .1 Production of Oils from Crude Oil ( 1 hour)**
- .2 Properties and characteristics of fuels and lubricants ( 1 hour)**
- Analyse the various properties of fuels and lubricating oils.
- .3 Shore side and shipboard sampling and testing ( 1 hour)**
- Appraise the importance and implications of continual monitoring of quality of fuels and lubricants in efficient operation of machinery.
  - Explain the procedures available for testing fuels and lubricants, including viscosity, water in oil, density, pour point, total base number (TBN), microbiological contamination and other contamination.
- .4 Interpretation of test results ( 1 hour)**
- Describe the facilities available for laboratory testing of fuels and lubricants, the properties that can be determined, and how the results can be interpreted and utilised in maintenance programme
- .5 Contaminants including microbiological infection (2 hours)**
- Outline procedures for dealing with contamination of oils by water, fuel in lubricating oil, solid debris or other contaminants, including recognition of unacceptable levels and possible consequences
  - Examine the causes, symptoms, effects and methods of treatment of oils that have been infected with microbiological organisms.
- .6 Treatment of fuels and lubricants including storage, centrifuging, blending, pretreatment and handling. ( 4 hours)**
- Detail bunkering procedures and arrangements, explaining the importance of following correct procedures
  - Evaluate the operation of centrifugal separators and analyse the factors that affect optimum separation
  - Explain the function and operation of a shipboard fuel blender and alternative fuel treatments.

#### **1.2.7 TECHNOLOGY OF MATERIAL**

Required Performance :

- .1 Metallurgy of Steel and Cast Iron ( 1 hour)**
- Basic steel and cast iron making process
  - Study of Iron - Iron Carbide diagram

**.2 Properties and application of material used in machinery on board ships**

**( 2 hours)**

- Explain the properties of materials and how these can be determined by simple tests
- Compare common non-metallic materials used at sea and explain their properties, applications and restrictions on usage
- Examine common metallic materials used at sea, their applications, failure mechanisms, and methods to limit or reduce failures.

**.3 Destructive and non-destructive testing of material ( 3 hours )**

- Describe common methods of non-destructive testing of materials and their application to main and auxiliary machinery components.
- Discuss destructive tests on specimens such as stress tests, hardness tests and metallographic tests.

**.4 Engineering processes used in construction and repair ( 4 hours )**

- Evaluate common fabrication techniques, including welding, forging, and casting
- Assess common repair techniques.

**.5 Materials and Welding**

- Types of steel used
- Designation of material types
- Welding processes
- Electrodes
- Forged, rolled, cast sections
- Edge preparation prior to welding
- Consideration of strength of welded sections
- Joining of different materials
- Construction and repairs
- Testing of weldments

**1.2.8 NAVAL ARCHITECTURE AND SHIP CONSTRUCTION INCLUDING DAMAGE CONTROL**

(Refer to 4.1.1, 4.1.2 and 4.1.3)

**COMPETENCE 1.3 OPERATION,SURVEILLANCE,PERFORMANCE ASSESSMENT AND MAINTAINING SAFETY OF PROPULSION PLANT AND AUXILIARY MACHINERY**  
*Practical knowledge*

**TRAINING OUTCOMES:**

Demonstrates a knowledge and understanding of:

**1.3 OPERATION,SURVEILLANCE,PERFORMANCE ASSESSMENT AND MAINTAINING SAFETY OF PROPULSION PLANT AND AUXILIARY MACHINERY** *Practical knowledge*

**1.3.1** START UP AND SHUT DOWN MAIN AND AUXILIARY MACHINERY, INCLUDING ASSOCIATED SYSTEM

**1.3.2** OPERATING LIMITS OF PROPULSION PLANTS

**1.3.3** THE EFFICIENT OPERATION, SURVEILLANCE, PERFORMANCE ASSESSMENT AND MAINTAINING SAFETY OF PROPULSION PLANT AND AUXILIARY MACHINERY

**1.3.4** FUNCTIONS AND MECHANISM OF AUTOMATIC CONTROL FOR MAIN ENGINE

**1.3.5** FUNCTIONS AND MECHANISM OF AUTOMATIC CONTROL FOR AUXILIARY MACHINERY:

**COMPETENCE 1.3 OPERATION, SURVEILLANCE, PERFORMANCE  
ASSESSMENT AND MAINTAINING SAFETY OF  
PROPULSION PLANT AND AUXILIARY MACHINERY**  
*Practical knowledge*

**1.3.1 START UP AND SHUT DOWN MAIN AND AUXILIARY MACHINERY,  
INCLUDING ASSOCIATED SYSTEM**

Required Performance:

**.1 Engine components ( 18 hours)**

- Interpret static and dynamic loads and stresses, identifying service limitations of diesel engine components.
- Evaluate different fabrication methods of diesel engine components, including:
  - Welding
  - Forging
  - Utilising composite materials
  - Plasma-spraying
  - Laser hardening and
  - Use of ceramics and other special materials.
- Identify two and four stroke operating cycle forces, couples, and moments, relating these to design principles of:
  - Crankshafts
  - Bedplates
  - Foundations
  - Crossheads.
- Explain out of balance gas and inertia forces, couples, and moments, and relate these to flywheels, balance weights, and first/second order balancing, and hull vibration.
- Explain factors contributing to torsional vibration, and identify methods of minimising or eliminating harmful effects of critical speeds.
- Evaluate the calibration of:
  - Pistons
  - Cylinder liners
  - Piston rings
  - Bearings
  - Crankshafts, to identify wear patterns, limits, and means of correction
- Specify alignment and adjustment criteria of:
  - Crankshafts
  - Chain drives
  - Gear drives
  - Integral thrust bearings
  - Crossheads.

- Compile specified working clearances and limits of all bearings, sliding surfaces, and interference fits of a typical diesel engine, using engine builders' manuals.

## **.2 Engine Lubrication ( 8 hours )**

- Identify diesel engine lubricant types, properties, and applications.
- Outline principles of diesel engine lubrication.
- In relation to contamination and deterioration of diesel engine lubricants:
  - Discuss the sources, types, and effects of contamination
  - Discuss the causes, types, and effects of deterioration
  - Describe typical testing and treatment methods, and
  - Interpret typical results of testing, giving appropriate actions which should be undertaken
- Describe, using diagrams, the distribution of lubricating oil to diesel engines, in particular the:
  - Guides and crosshead bearings of slow speed diesel engines
  - Top end bearings of medium speed engines
  - Bottom end bearing
  - Main bearings
  - Camshaft drives, showing direction of flow, typical clearances, and stating normal operating parameters.

## **.3 Fuel Injection ( 12 hours )**

- Explain why atomisation and penetration of fuel and the turbulence of air are essential to optimum combustion in a diesel engine.
- State typical injection pressures and viscosities for different grades of fuel.
- Describe how and why fuel pumps, camshafts, and injectors are altered for varying fuel types.
- Describe, with the aid of simple sketches, the difference between constant and variable injection timing of fuel, showing materials, principal parts, methods of operation and adjustments of common types of fuel pump.
- Compare injection requirements for slow speed, medium speed, and high speed diesel engines, including pilot injection and pre-combustion chambers.
- Identify common service faults, symptoms, and causes of combustion problems, specifying appropriate adjustments, including methods of fuel pump timing.
- Summarise Occupational Health & Safety aspects of handling and testing fuel injection systems.
- Explain, using relevant diagrams and stating normal operating parameters:
  - Fuel valve cooling arrangement

- Uni-fuel and dual-fuel systems (for high/medium viscosity fuel types)
- Discuss the atmospheric pollution aspects of diesel engine combustion, and give methods which reduce this pollution (especially SO<sub>x</sub> and NO<sub>x</sub> reduction).

**.4 Scavenging and Supercharging ( 10 hours)**

- Evaluate the need for scavenging diesel engines
- Compare methods of scavenging diesel engines
- Specify methods of providing pressurised air for combustion in diesel engines
- Assess pressure charging methods for diesel engines
- Assess pressure charging methods for diesel engines
- Examine the working principles of turbochargers
- Assess lubrication and cooling requirements of turbochargers
- Analyse typical faults and identify appropriate actions to be undertaken with defective or damaged turbochargers.

**.5 Starting and Reversing ( 8 hours)**

- Describe starting procedures of diesel engines for power generation, propulsion, and emergency use.
- Explain starting and maneuvering requirements/sequences for direct coupled reversible and geared propulsion diesel engines, for fixed and controllable pitch propeller applications
- Describe, with labeled diagrams to indicate major components, typical manoeuvring and reversing systems for propulsion diesel engines
- Compare different methods of reversing direct coupled propulsion diesel engines
- Identify common faults and identify appropriate actions to be undertaken with typical diesel engine starting and maneuvering systems
- Compare the different methods of utilising diesel engines for ship propulsion, including:
  - Direct coupled, reversible slow and medium speed engines
  - Clutched and geared reversible and unidirectional medium speed engines with a fixed pitch propeller
  - Clutched and geared reversible and unidirectional medium speed engines with a controllable pitch propeller, and
  - Diesel electric drive.

**.6 Cooling systems ( 4 hours )**

- Analyse the problems that may arise in cooling water spaces of diesel engines.
- Evaluate common methods of diesel engine cooling water treatment.
- State the importance of maintaining diesel engine thermal efficiency and evaluate thermal loads on engine components.
- Justify cooling media selection and state the advantages and disadvantages of various diesel cooling methods.

- Evaluate the tests used in the control of diesel engine cooling water treatment.
- Enumerate the normal operating limits for diesel engine cooling water treatment.
- Interpret the implications of out of limit readings from water treatment tests and state the corrective procedures which should be undertaken.
- Itemise the sources and types of contamination of diesel engine cooling water and explain the effects of these contaminations on the reserves of treatment chemicals.
- Compare the procedures which may be used to counter contamination of diesel engine cooling water.
- Explain, using relevant diagrams and stating normal operating parameters, typical methods of cooling:
  - Medium and slow speed diesel engine pistons
  - Exhaust valves
  - Cylinders
  - Turbochargers
  - Cylinder heads

## **.7 Diesel Engine Control and Safety**

**( 4 hours )**

- With respect to waste heat units:
  - Explain the design and operational factors that contribute to fires in waste heat units
  - Discuss the generation of soot and hydrogen fires
  - Explain the possible consequences of such fires
  - Identify routine cleaning and inspection criteria
  - Identify symptoms of a fire
  - Give appropriate actions to be undertaken upon fire detection in order to contain/extinguish the fire, and
  - Identify the risks of isolating a waste heat unit.
- With respect to scavenge fires:
  - Explain the factors that contribute to a fire in the scavenge chamber of a diesel engine
  - Explain the possible consequences of such fires
  - Specify detection, protection, and extinguishing devices
  - Identify routine cleaning and inspection criteria
  - Identify symptoms of a fire, and
  - Give appropriate actions to be undertaken upon fire detection in order to contain/extinguish the fire.
- With respect to starting air lines:
  - Identify principles of explosive mixtures
  - Describe how an air line explosion can occur
  - Explain the possible consequences of such an explosion
  - Identify routine evaluation criteria of starting air systems for minimising/avoiding an explosion, and



- State how the risk of explosion may be minimised/avoided by protection devices.
- With respect to diesel engine crankcases and gearboxes:
  - Explain the factors and sequence of occurrences that contribute to generation of explosive oil mist
  - Discuss the generation of primary and secondary explosions in these spaces
  - Explain the possible consequences of such explosions
  - Specify detection and protection devices
  - State how the risk may be minimised in service
  - State indications of hot spots and possible explosive atmospheres, and
  - Give the correct procedure to be undertaken upon indication of a potentially explosive atmosphere, in both diesel and dual fuel engines.
- Evaluate the causes and consequences of diesel engine overspeed, and give procedures which must be undertaken in the event of such an occurrence.
- Explain, using diagrams, the operating principles of:
  - Oil mist detectors, giving testing procedures
  - Explosion relief doors
  - Crankcase breathers
  - Crankcase extraction fans.

**.8 Diesel Engine Emergency operation ( 2 hours )**

- Explain emergency procedures for maneuvering for diesel engines.
- Explain emergency procedures which may be undertaken with defective clutches.

**.9 Multi-engine Propulsion Arrangement ( 2 hours )**

- Explain the need for changing the output speed of prime movers.
- Define gearing concepts, and explain the advantages and disadvantages of:
  - Utilising gearing to change prime mover output speed
  - Involute gearing
  - Spur and helical gears
- Assess the need for disengaging prime movers from drive lines
- Identify common types of clutches and couplings used with prime movers
- Outline maintenance procedures associated with clutches.

**.10 Air compressors and compressed air systems (3 hours)**

- Examine the functions and operation of all components including fittings and safety devices of air compressors and compressed air systems
- Evaluate the effects of common operational faults of single and multi-stage air compressors, including: leaking valves, leaking piston rings,

- blocked filters, blocked coolers
- Explain the reasons and the effects of high levels of oil or water in compressed air
- Explain the effects of operating air compressors with synthetic lubricating oils compared to operating with mineral lubricating oils
- Describe a procedure for inspecting and maintaining air receivers and their fittings.

**.11 Hydraulic power system (6 hours)**

- Analyze functions and operation of all components including fittings and safety
- Devices of hydraulic power systems
- Interpret symptoms, effects, and remedial actions for common faults in hydraulic power systems.

**.12 Types of auxiliary boilers (9 hours)**

- Examine typical boiler types illustrating cross sections, attachments and locations of all fittings, mountings, scantlings and methods of achieving water circulation and gas flow
- Distinguish the material requirements for boiler components
- Explain the construction of typical types of boilers
- Explain functions and operation of all boiler components including fittings and safety devices
- Illustrate a typical boiler fuel system and its components
- Examine the operation and maintenance procedures of boiler fuel systems
- Analyze the combustion process, its monitoring system, and requirements for proper combustion
- Evaluate common types of burners and distinguish how atomization and subsequent combustion is achieved
- Identify the protection devices, alarms, and shutdowns used in combustion control and fuel systems, and analyze their importance and methods of operation.

**.13 Auxiliary steam system (2 hours)**

- Illustrate a typical auxiliary steam system, showing the location and purpose of all components
- Develop a heat energy balance for an auxiliary steam system
- Distinguish the material requirements for auxiliary steam system components
- Examine the construction and operation of typical auxiliary steam system components
- Explain the reasons for operating the auxiliary steam plant and its systems at nominated temperatures and pressures, and the effects of departing from these parameters

- Analyse the symptoms of faults in steam traps, hot wells, de-aerators and condensers
- Analyse the requirements for contamination prevention between systems.

**.14 Safety valves (4 hours)**

- Analyse the requirements for steam safety valves.
- Analyse the design formulae used for steam safety valves.
- Differentiate between common types of boiler safety valves in use and explain how they are classified in terms of valve lift.
- Distinguish the materials of construction of safety valves.
- Analyse operational problems that can occur with safety valves.
- Examine how a safety valve is inspected and overhauled, giving common defects and areas of importance when inspecting.
- Formulate a procedure for setting safety valves, and examine the precautions necessary when testing safety valves on boilers and waste heat unit.

**.15 Boiler water levels (6 hours)**

- Discuss requirements for boiler water level indicators
- Differentiate between common types of local boiler water level indicator in use, explaining their different methods of construction and operation
- Evaluate testing, maintenance and defect rectification procedures for local boiler water level indicators
- Differentiate between common types of remote boiler water level indicator in use, explaining their different methods of construction and operation
- Evaluate testing, maintenance and defect rectification procedures for remote boiler water level indicators.

**.16 Use of 'Sea water in Boilers' (0.5 hour)**

- Explain the reasons and the effects of using sea water in Boilers.

**.17 Use of 'Fresh Water in Boilers' (0.5 hour)**

- Analyze the different types of impurities present in boiler, feed and make up water.
- Explain how salts are precipitated from boiler and feed water, and the consequences of this precipitation.
- Explain how metal is corroded in the boiler and feed system.

**.18 Boiler Water Testing (3 hours)**

- Define pH and explain how it is measured and controlled.
- Evaluate the tests used in the control of boiler and feed water treatment.
- Interpret the implications of out of limit readings from water treatment tests and state the corrective procedures which should be undertaken.

**.19 Boiler Water Treatment (9 hours)**

- Evaluate common methods of boiler, feed and make up water treatment.
- Show how oxygen is eliminated in boilers.
- Enumerate the normal and maximum operating limits for boiler and feed water treatment
- Itemise the sources and types of contamination of boiler, feed, and make up water and explain the effects of these contaminations on the reserves of treatment chemicals
- Compare the procedures which may be used to counter contamination of boiler, feed, and make up water.

**.20 Auxiliary Steam turbines (9 hours)**

- Analyze the types, uses, and methods of construction of auxiliary steam turbines in use at sea
- Examine the typical operating conditions, including temperatures and pressures, of auxiliary steam turbines
- Identify the materials used in auxiliary steam turbines and ancillary equipment
- Examine typical operational problems associated with auxiliary steam turbine plants, the symptoms, effects, and possible remedies of these faults
- Explain the processes of warming through and shutting down auxiliary steam turbine plants
- Outline the maintenance associated with optimum performance of an auxiliary steam turbine plant.

**.21 Boiler defects (3 hours)**

- Identify the possible defects which may occur in a boiler, gas and water side, giving their location, nature, and effects
- Outline procedures commonly employed to rectify defects in boilers, and explain the limitations of such repairs
- Enumerate procedures for leak detection in boilers and other steam system components, and explain the remedial actions which may be undertaken

**.22 Boiler and Steam turbine survey and repairs (6 hours)**

- Examine the need for surveying auxiliary boilers, steam turbines and other components of auxiliary steam systems
- Outline survey requirements for auxiliary boilers, steam turbines and other components of auxiliary steam systems
- Outline the procedures for shutting down, isolating and opening up an auxiliary boiler for inspection or during an emergency.

**.23 Evaporators (6 hours)**

- Compare operation, performance, problems and applications of common fresh water generation plants used at sea
- Evaluate the need for treatment of evaporator water, and assess methods of fresh water generation plant water treatment.

**.24 Thermal fluid heating system (3 hours)**

- Examine typical thermal fluid heating systems and explain the advantages and disadvantages of these systems
- Explain the locations and functions of all components, fittings, and safety devices used in thermal fluid systems
- Analyze the properties of thermal fluids used, effects of contamination, and methods of testing the fluid
- Compare thermal fluid plants with conventional steam plants.

**1.3.2 OPERATING LIMITS OF PROPULSION PLANTS**

Refer to 1.2.3

**1.3.3 THE EFFICIENT OPERATION, SURVEILLANCE, PERFORMANCE ASSESSMENT AND MAINTAINING SAFETY OF PROPULSION PLANT AND AUXILIARY MACHINERY**

Required Performance :

**.1 Diesel engines (10 hours)**

- Indicator and draw diagrams
  - Compression pressure, maximum pressure and faults
  - Area of indicator diagram
  - Calculation of indicated and effective engine power
  - Calculating turbocharger efficiency
  - Estimation of effective engine power without indicator diagrams
    - ❖ Fuel index
    - ❖ Turbocharger speed
- Detection of fault from indicator diagrams
- Engine condition monitoring and evaluation system
  - On line system with automatic sampling of engine parameters supplemented by cylinder pressure measurement
  - Engine diagnosis system and computer controlled surveillance.

**1.3.4 FUNCTIONS AND MECHANISM OF AUTOMATIC CONTROL FOR MAIN ENGINE**

Refer to 2.1.2.2

### 1.3.5 FUNCTIONS AND MECHANISM OF AUTOMATIC CONTROL FOR AUXILIARY MACHINERY:

Required Performance :

#### .1 Generator distribution system

Refer to 2.1.2.3

#### .2 Steam boiler

Refer to 2.1.2.4

#### .3 Oil purifier (3 hours)

- Automation, monitoring and alarms
  - Temperature control
  - Automatic start
  - Automatic desludging
    - ❖ Partial desludging
    - ❖ Total desludging
  - Monitoring and alarms
    - ❖ Low/high temperature
    - ❖ Water content
    - ❖ Leakage monitoring
      - Treated oil flowing into heavy liquid side
      - Non-closure of bowl
  - Discharge detector for monitoring sludge discharge

#### .4 Refrigeration and air conditioning system (3 hours)

- Automation, monitoring and alarms in refrigeration system
  - If pump down cycle used on board for refrigeration system:
    - ❖ Automatic shutdown of compressor when all cold rooms attain temperature by shutting off of solenoid valves and low pressure cut out in suction line
    - ❖ When one or more cold rooms temperature rises and solenoid valve/s open and suction pressure rises, thereby suction cut in operates and automatic start of compressor
    - ❖ Automatic shut down and alarm in case of high pressure in discharge line. Manual reset for restarting of compressor
    - ❖ Automatic shut down of compressor and alarm in case of low pressure of lubricating oil
    - ❖ Timer control for defrosting of evaporator coils of meat room and fish room

- Capacity control may be used on board for refrigeration compressor
- Automatic control of steam spray for accommodation air conditioning heating system

**.5 Pumping and piping system (1 hour)**

- Pumping and piping system
  - Automatic start of standby pumps
  - Automatic start/stop of hydrophore pumps
  - Automatic water level control of boiler by feed pumps
  - Automatic cargo stripping system onboard tankers
  - Automatic heeling system

**.6 Steering gear system (2 hour)**

- Autopilot system
- Regaining of steering capability in case of single failure of the hydraulic system

**.7 Cargo-handling equipment and deck machinery (1 hour)**

- Self-tensioning mooring winches
- Automatic shut down of cargo -pumping on abnormal operating conditions of inert gas system on board tankers.
- Automatic shut down of cargo pumping / loading on tankers and gas carriers.

**COMPETENCE 1.4 MANAGE FUEL, LUBRICATION AND BALLAST OPERATIONS**

**TRAINING OUTCOMES:**

Demonstrates a knowledge and understanding of:

**1.4 MANAGE FUEL, LUBRICATION AND BALLAST OPERATIONS**

**1.4.1 OPERATION AND MAINTENANCE OF MACHINERY, INCLUDING PUMPS AND PUMPING SYSTEM**

## **COMPETENCE 1.4 MANAGE FUEL, LUBRICATION AND BALLAST OPERATIONS**

### **1.4.1 OPERATION AND MAINTENANCE OF MACHINERY, INCLUDING PUMPS AND PUMPING SYSTEM**

Required Performance:

#### **.1 Ballast (2 hours)**

- Describe procedures for evaluating pumps, ejectors, and pumping systems including ship side valves, explain methods of identifying problems which affect performance, and identify common faults and evaluate methods of assessment.
- Illustrate the operation of self priming systems as used on ballast or cargo pumping arrangements.
- Explain the main causes of corrosion in sea water systems and the regions most affected.
- Compare corrosion and marine growth prevention systems used for pumps and pumping systems, including impressed current, sacrificial anodes, chemical injection, special coatings, chlorination, and special materials.

#### **.2 Bilge (2 hours)**

- Describe procedures for evaluating pumps, ejectors, and pumping systems including ship side valves, explain methods of identifying problems which affect performance, and identify common faults and evaluate methods of assessment.
- Illustrate the operation of self priming systems as used on bilge pumping arrangements.
- Explains the purpose and procedure for using bilge injection.

#### **.3 Fire Main (2 hours)**

- Describes the number and source of supply to the fire main for the given ship
- Explains how and when fire pumps should be tested
- Describes the uses to which a fire main can be put
- Explains the purpose of the fittings on a fire main

#### **.4 Prevention of Pollution of the Sea by Oil (4 hours)**

- Describes in principle how bilge and ballast water are discharged
- Lists the precautions to be taken when bunkering fuel oil and lubricating oil.
- Describes the requirements for oily water separators.



- Explains how the mode and type of pump used affects the contamination of oily water.
- Explains how the temperature, relative density and size of oil particles affect the separation process.
- Explains the principles of the operation of a two stage and three stage automatic oily water separator.
- Explains why and where pressure relief devices are fitted to a separator.
- Describes the function of a coalescer.
- Explains the principles and purpose of a separator probe.
- Describes how the automatic valve is controlled and operated.
- Lists the safeguards in an oily water separator system.
- Describes the automatic cleaning of an oily water separator.

## **.5 Sewage and sludge**

**(4 hours)**

- Describes a sewage retention system
- Explains why vacuum transportation systems are used
- Describes the process where a comminutor and treatment with chlorine are used
- Describes the processes in a biological treatment plant
- Explains how the sludge from a biological treatment plant is disposed of
- Explains why biological treatment should be kept working continuously
- Names the contaminants which would impair the treatment process
- Describes the operation of chemical treatment plants
- Lists the waste materials that can be incinerated
- Explains how liquid and solid waste are prepared for combustion in an incinerator

## Part D1: INSTRUCTOR MANUAL

### Function 1: Marine Engineering at the Management Level

#### ■ General

The following notes are intended to highlight the main objectives or training outcomes of each part of the function. The notes also contain some material on topics which are not adequately covered in the quoted references.

This function covers the competences concerned with planning and scheduling operations; start-up and shut-down of main and auxiliary machinery; performance monitoring; safety management and fuel and ballast operations management.

Whilst dealing with theoretical and mathematical subjects, instructors are advised to provide suitable practical examples, related to shipboard applications. This would enhance the trainees achieve a better and thorough understanding of the principles involved in the theory.

#### 1.1 MANAGE THE OPERATION OF PROPULSION PLANT MACHINERY

##### 1.1.1 DESIGN FEATURES, AND OPERATIVE MECHANISM OF MARINE DIESEL ENGINE AND ASSOCIATED AUXILIARIES

##### **1.1.1.1 Design features and operative mechanism of Marine Diesel Engines and associated auxiliaries (35 hours)**

Instructors to consult V5,V12, V70, V78, T10, T15, T20,T21,T22,T40,T41 and T44 for this subject, to deal with topics that (i)Describe with the aid of sketches/computer aided drawing, material selection, and design features of the structure of diesel engine (ii)Describe with the aid of sketches/computer aided drawing, material selection, and design features of the running gear of diesel engine (iii)Describe with the aid of sketches/computer aided drawing, material selection, and design features of the fuel injection equipment of diesel engine (iv)Describe with the aid of sketches/computer aided drawing, material selection, and design features of the combustion chamber components of diesel engine (v)Describe with the aid of sketches/computer aided drawing, material selection, and design features of piston rings, compatibility to cylinder liner and cylinder lubrication employed in a diesel engine: (vi)Describe with the aid of sketches the operative mechanism of diesel engine system

1.1.2 DESIGN FEATURES, AND OPERATIVE MECHANISM OF MARINE STEAM TURBINE AND ASSOCIATED AUXILIARIES

**1.1.2.1 Design features and operative mechanism of a Marine Steam Turbines and associated auxiliaries (5 hours)**

Instructors to consult V10, V74, T8, T38, T42 and T45 for this subject, to deal with topics which (i) Describe with the aid of sketches/computer aided drawing, material selection and design features of steam turbines (ii) Describe with the aid of sketches the operative mechanism of steam turbines

1.1.3 DESIGN FEATURES, AND OPERATIVE MECHANISM OF MARINE GAS TURBINE AND ASSOCIATED AUXILIARIES

**1.1.3.1 Design features and operative mechanism of Marine Gas Turbines and associated auxiliaries (10 hours)**

Instructors to consult V65, T2, T22 T64 for this subject to deal with topics which (i) Describe with the aid of sketches/computer aided drawing, material selection and design features of gas turbines and (ii) Describe with the aid of sketches the operative mechanism of a Marine Gas Turbine

1.1.4 DESIGN FEATURES, AND OPERATIVE MECHANISM OF MARINE STEAM BOILER AND ASSOCIATED AUXILIARIES

**1.1.4.1 Design features and operative mechanism of Marine Steam Boiler and associated auxiliaries (15 hours)**

Instructors to consult V10, V74, T8, T38, T42 and T45 for this subject to deal with topics which (i) Describe with the aid of sketches/computer aided drawing, material selection and design features of marine steam boilers and (ii) Describe with the aid of sketches/computer aided drawing, material selection and design features of marine steam boiler feed water systems

1.1.5 DESIGN FEATURES, AND OPERATIVE MECHANISM OF PROPELLER SHAFT AND ASSOCIATED ANCILLARIES

**1.1.5.1 Describes with the aid of sketches/computer aided drawing, material selection and design features of propeller shaft and associated ancillaries (10 hours)**

Instructors to consult T7, T11, T19, T35 and T36 for this subject to deal with topics *related to* (i) Establishing the shaft centre line (ii) Deviation while building (iii) Alignment deviation in service (iv) Fair curve alignment (v) Shaft checks (vi) Shaft bearings (vii) Coupling bolts (viii) Stern tubes (ix) Stern tube sealing arrangements (x) Fixed pitch propellers (xi) Methods of mounting fixed pitch propellers (xii) Controllable pitch propellers (xiii) Gears and clutches (xiv) Reverse reduction gearbox (xv) Flexible couplings and (xvi) Air operated clutches

## 1.1.6 TECHNICAL COMMUNICATIONS FOR DESIGN

### **1.1.6.1 Technical Communications for design (40 hours)**

This unit is to be taught in a classroom with access to a complete range of audio visual presentation equipment. Practical demonstration equipment capable of being used by the instructor to illustrate points, and subsequently by students to reinforce points, will be available. The teaching method used will be by standard lecture. Ship visits will be desirable to show students actual systems and components, but this will depend on availability of vessels.

Instructors to consult T35 for this subject and are advised to use computer soft-ware like Auto-Cad, MATLAB.FEM and CFD to deliver topics on (i)Drawing (ii)Technical Literature (iii) Operations Manual (iv) Drawing Environment (v) Basic Techniques (vi)2D Drawing (vii)Dimensioning and Annotating (viii) Plotting and (ix) Use of Engineering Design and Mathematical Software (x) Basic exposure to AutoCAD, Finite Element Methods (FEM), Computational fluid dynamics (CFD) and Matrix Laboratory (MATLAB).

## 1.1.7 MANAGE THE OPERATION OF STEAM PROPULSION PLANT MACHINERY

### **1.1.7.1 DESIGN FEATURES AND OPERATIVE MECHANISM OF MARINE STEAM TURBINE AND ASSOCIATED AUXILIARIES (30 hours)**

Instructors to consult V10, V74, T8, T38, T42 and T45 for this subject to deal with topics which describes with the aid of sketches/computer aided drawing, material selection and design features of steam turbines, the operative mechanism of steam turbines, material selection and design features of steam turbine gear box.

### **1.1.7.2 DESIGN FEATURES AND OPERATIVE MECHANISM OF MARINE STEAM TURBINE AND ASSOCIATED AUXILIARIES (35 hours)**

Instructors to consult V10, V74, T8, T38, T42 and T45 for this subject to deal with topics which describes with the aid of sketches/computer aided drawing, material selection and design features of marine steam boilers, boiler mountings and accessories and feed water systems.

### **1.1.7.3 PROPULSIVE CHARACTERISTICS OF STEAM TURBINE (10 hours)**

Instructors to consult V10, V74, T2, T8, T18 T38, T42 and T45 for this subject to deal with topics related to propulsive characteristics of Steam Turbine

**1.1.7.4 THE EFFICIENT OPERATION, SURVEILLANCE, PERFORMANCE ASSESSMENT AND MAINTAINING SAFETY OF PROPULSION PLANT AND AUXILIARY MACHINERY (10 hours)**

Instructors to consult V10, V74, T2, T8, T18 T38, T42 and T45 for this subject to deal with topics related to 1.1.4

**1.2 PLAN AND SCHEDULE OPERATIONS *Theoretical knowledge***

**1.2.1 THERMODYNAMICS AND HEAT TRANSMISSION**

**1.2.1.1 Thermodynamic Fundamentals (6 hours)**

Instructors should consult T2 and T18 for this subject to deal with the topics on (i) System and working substance (ii) SI Units. Property and State (iii) Reversible and Irreversible processes (iv) Reversible work of compression or expansion (v) First Law applied to non-flow and flow processes and (vi) Throttling, nozzles and mixing of streams.

**1.2.1.2 Perfect Gas (12 hours)**

Instructors should consult T2 and T18 for this subject to deal with the topics on (i) Equation of State (ii) Specific Heats. Internal Energy (iii) Adiabatic, polytropic, isobaric and isothermal compression/expansion (iv) Enthalpy and (iv) Gas mixtures and Daltons Law of partial pressures.

**1.2.1.3 Second Law (12 hours)**

Instructors should refer to T2 and T18 for this subject to deal with the topics on (i) Classical statements (ii) Heat engine (iii) Thermal efficiency (iv) Entropy (v) Isentropic process (vi) Reversible heat engine (vii) Temperature – entropy (T-s) diagram for a perfect gas and (viii) Isentropic efficiency.

**1.2.1.4 Gas Cycles/Engine Analysis (12 hours)**

Instructors should refer to T2 and T18 for this subject to deal with the topics on (i) Constant pressure and constant volume air standard cycles (ii) Reciprocating internal combustion engine performance (iii) Open and closed gas turbine systems and (iv) Power, isentropic efficiency and thermal efficiency for gas turbines.

**1.2.1.5 Properties of Vapours (6 hours)**

Instructors should refer to T2 and T18 for this subject. Saturation, dryness fraction and superheat. (i) T-s, p-h, p-v, h-s diagrams (ii) Fluid properties using steam tables (iii) Throttling and separating calorimeters and (iv) Air in condensers.

Trainees should understand that the principles of steam apply to other vapours. Trainees should have used tables of thermodynamic properties in earlier studies and will need to use them in various training outcomes.

### **1.2.1.6 Steam Cycles**

**(9 hours)**

Instructors should refer to T2 and T18 for this subject to deal with the topics on  
(i) Rankine cycle. Turbine isentropic efficiency (ii) Feed heating (iii) Thermal efficiency and (iv) Cycle on T-s diagram.

### **1.2.1.7 Steam Turbine Velocity Diagrams**

**(3 hours)**

Instructors should refer to T2 and T18 for this subject to deal with the topics on  
(i) Principles of reaction and impulse turbines including compounding (ii) Velocity diagrams  
(iii) Nozzle steam velocity (excluding proof of critical pressure ratios) and (iv) Force and work done on blades.

### **1.2.1.8 Refrigeration**

**(6 hours)**

Instructors should refer to T2 and T18 for this subject to deal with the topics on  
(i) Vapour compression cycle (ii) Refrigerant properties and hazards (iii) Refrigerant tables (iv) Cycle on p-h diagram (v) Coefficient of performance (vi) Refrigerant mass flow (vi) Compressor calculations and (vii) Secondary refrigerants.

### **1.2.1.9 Combustion**

**(6 hours)**

Instructors should refer to T2 and T18 for this subject to deal with the topics on  
(i) Combustion equations (ii) Fuel composition (iii) Air-fuel ratio (iv) Excess air (iv) Volumetric analysis of combustion products and (v) Calorific value.

### **1.2.1.10 Compressors**

**(3 hours)**

Instructors should refer to T2 and T18 for this subject to deal with the topics on  
(i) Reciprocating compressors and (ii) Positive displacement rotary compressors:

### **1.2.1.11 Heat Transfer**

**(12 hours)**

Instructors should refer to T2 and T18 for this subject to deal with the topics on  
(i) Conduction, radiation and convection (ii) Composite walls; Insulation (iii) Film coefficient (iv) Interface temperature (v) Stefan-Boltzmann Law (vi) Parallel flow and cross flow heat exchangers and (vii) Logarithmic mean temperature difference.

### **1.2.1.12 Air Conditioning**

**(3 hours)**

Instructors should refer to T2 and T18 for this subject to deal with the topics on  
(i) Comfort conditions (ii) Psychometric charts (iii) Wet and dry bulb temperatures (iv) Humidity (v) Dew point (vi) Dehumidifying and humidifying processes and (vii) Air conditioning systems.

## 1.2.2 MECHANICS AND HYDROMECHANICS

### 1.2.2.1 Statics

(8 hours)

Instructors should refer to T1 and T17 for this subject to explain (i) Bow's notation (ii) Force analysis by method of sections and (iii) Framed structures.

### 1.2.2.2 Dynamics

(14 hours)

Instructors should refer to T1 and T17 for this subject to explain (i) Equations of motion (ii) Velocity and acceleration diagrams (iii) Laws of conservation of energy and momentum (iv) Collision of rigid and elastic bodies (v) Projectiles (vi) Engine mechanisms (vii) Flywheels (viii) Hoists (ix) Cams (x) Governors (xi) Simple and epicyclic gear systems and (xii) Vehicle dynamics.

### 1.2.2.3 Friction

(4 hours)

Training outcome, Friction, is intended to be a qualitative treatment and should be illustrated using marine engineering applications. Determine frictional losses in rotating Journal bearings

Instructors should refer to T1 and T17 for this subject to explain (i) Sliding friction on horizontal and inclined planes (ii) Cotter keys (iii) Screw threads (iv) Belt drives (v) Friction brakes and (vi) Plate and cone clutches.

### 1.2.2.4 Balancing

(4 hours)

Instructors should refer to T1 and T17 for this subject to explain (i) Primary and secondary forces (ii) Primary and secondary couples and (iii) Complete balancing of reciprocating machinery.

### 1.2.2.5 Simple Harmonic Motion

(6 hours)

Instructors should refer to T1 and T17 for this subject to explain (i) Equation of simple harmonic motion (ii) Amplitude, frequency and periodic time (iii) Vibrating spring mass systems (iv) Springs (v) Resonance (vi) Transmissibility and (vii) Vibrations of flywheels and gearwheels.

### 1.2.2.6 Stress & Strain

(10 hours)

Instructors should refer to T1 and T17 for this subject to explain (i) Stress and strain relationships in thin cylindrical and spherical shells (ii) Stress in thin, rotating rims (iii) Thermal stress (iv) Stress in compound bars (v) Elastic strain energy and (vi) Stresses due to gradually applied and shock loads.

### **1.2.2.7 Bending of Beam**

**(12 hours)**

Instructors should refer to T1 and T17 for this subject to explain (i) Shear force and bending moment diagrams (ii) Fundamental bending equation (iii) Bending stresses and (iv) Deflection of beams. Macaulay's method

Instructors should relate the theory to components used on board vessels. A typical example could be use of long bolts for Main propulsion engine bedplate connection to tank top, to reduce bending stresses.

### **1.2.2.8 Torsion**

**(8 hours)**

Instructors should refer to T1 and T17 for this subject to explain (i) Stress, strain and strain energy due to torsion (ii) Fundamental torsion equation (iii) Reciprocating engine crank effort (iv) Rudder stock turning moment from steering gear (v) Deflection of helical springs and (vi) Instructors should relate the theory to components used on board vessels. Highlight the advantages of using a hollow shaft in marine application compared to a solid shaft.

### **1.2.2.9 Struts**

**(4 hours)**

Instructors should refer to T1 and T17 for this subject to explain (i) Euler's formula and (ii) Slenderness ratio.

### **1.2.2.10 Combined Stress**

**(4 hours)**

Instructors should refer to T1 and T17 for this subject to deal with topics on (i) Stresses on an oblique plane (ii) Material subjected to two perpendicular stresses (iii) Axial and bending stress (iv) Mohr's stress circle. Principal stresses and strains and (v) Combined bending and twisting.

### **1.2.2.11 Stresses In Thick Shells**

**(4 hours)**

Instructors should refer to T1 and T17 for this subject to deal with topics on (i) Lamé's equations (ii) The Lamé Line and (iii) Shrinkage allowance.

### **1.2.2.12 Fluid Mechanics**

**(12 hours)**

Instructors should refer to T1 and T17 for this subject to deal with topics on (i) Volume and mass flow (ii) Venturi meter (iii) Bernoulli's equation (iv) Jets. Orifice coefficients (v) Dynamic and kinematic viscosity (vi) Reynolds' number (vii) Flow losses in pipes and fittings (viii) Darcy's formula and (ix) Centrifugal pumps.



### 1.2.3 PROPULSIVE CHARACTERISTICS OF DIESEL ENGINES INCLUDING SPEED, OUTPUT AND FUEL CONSUMPTION

#### **1.2.3.1 Engine layout and load diagrams (7 hours)**

Instructors should refer to T20, T21 and T22 for this subject to deal with the topics on (i) Propeller curve (ii) Propeller design point (iii) Fouled hull, sea margin and heavy propeller (iv) Continuous service rating (v) Engine margin (vi) Constant ship speed lines (vii) Limits for continuous operation (viii) Limits for overload operation (ix) Specific fuel oil consumption (SFOC) (x) SFOC based on reference ambient conditions stated in ISO 3046/1-1986 (xi) Adjustment of SFOC for lower calorific value of fuels and ambient conditions different from ISO reference conditions

### 1.2.4 HEAT CYCLE, THERMAL EFFICIENCY AND HEAT BALANCE OF THE FOLLOWING

#### **1.2.4.1 Marine diesel engine (5 hours)**

Instructors should refer to T2 and T18 for this subject (i) Dual cycle (ii) Thermal efficiency of dual cycle and (iii) Heat balance of marine diesel engine

#### **1.2.4.2 Marine steam boiler and steam turbine (10 hours)**

Instructors should refer to T2 and T18 for this subject (i) Rankine cycle (ii) Thermal efficiency of Rankine cycle and (iii) Heat balance of a marine steam plant

#### **1.2.4.3 Marine gas turbine (5 hours)**

Instructors should refer to T2 and T18 for this subject (i) Brayton cycle (ii) Thermal efficiency of Brayton cycle and (iii) Heat balance of marine gas turbine plant

### 1.2.5 REFRIGERATORS AND REFRIGERATION CYCLE

#### **1.2.5.1 Refrigeration and Air Conditioning system (10 hours)**

Instructors should refer to V76, T48 and T49 for this subject to (i) Assess common refrigerants used on board, using factors such as their properties, economics of use, handling, health hazards, and environmental impact (ii) Explain the environmental concerns of traditional refrigerants and the methods used to address these concerns (iii) Explain correct procedures for the recovery of refrigerants from refrigeration systems (iv) Analyse functions and operation of all components including fittings and safety devices of refrigeration and air conditioning plants (v) Interpret symptoms, effects, and remedial actions for common faults in refrigeration and air conditioning systems (vi) Precautions during cargo operations – re-circulation system of AHU (vii) Explain the purposes and procedures for pumping down, leak test, refrigerant charging and oil changing (viii) Record keeping of refrigerant consumption.

## 1.2.6 PHYSICAL AND CHEMICAL PROPERTIES OF FUELS AND LUBRICANTS

### **1.2.6.1 Production of Oils from Crude Oil** (1 hour)

Instructors should refer to T7 and T11 for this subject

### **1.2.6.2 Properties and characteristics of fuels and lubricants** (1 hour)

Instructors should refer to V2, V88, T7 and T11 for this subject

### **1.2.6.3 Shore side and shipboard sampling and testing** (1 hour)

Instructors should refer to V10, T7 and T11 for this subject to:

(i) Appraise the importance and implications of continual monitoring of quality of fuels and lubricants in efficient operation of machinery and (ii) Explain the procedures available for testing fuels and lubricants, including viscosity, water in oil, density, pour point, total base number (TBN), microbiological contamination and other contamination.

### **1.2.6.4 Interpretation of test results** (1 hour)

Instructors should refer to T7 and T11 for this subject to describe the facilities available for laboratory testing of fuels and lubricants, the properties that can be determined, and how the results can be interpreted and utilised in maintenance programme.

### **1.2.6.5 Contaminants including microbiological infection** (2hours)

Instructors should refer to V6, T7 and T11 for this subject to (i) Outline procedures for dealing with contamination of oils by water, fuel in lubricating oil, solid debris or other contaminants, including recognition of unacceptable levels and possible consequences **and** (ii) Examine the causes, symptoms, effects and methods of treatment of oils that have been infected with microbiological organisms.

### **1.2.6.6 Treatment of fuels and lubricants including storage, centrifuging, blending, pretreatment and handling.** (4 hours)

Instructors should refer to V67, T7 and T11 for this subject to

Detail bunkering procedures and arrangements, explaining the importance of following correct procedures to (i) Evaluate the operation of centrifugal separators and analyse the factors that affect optimum separation and (ii) Explain the function and operation of a shipboard fuel blender and alternative fuel treatments.

## 1.2.7 TECHNOLOGY OF MATERIAL

### **1.2.7.1 Metallurgy of Steel and Cast Iron** (1 hour)

Instructors should refer to T7, T11 and T44 for this subject to explain (i) Basic steel and cast iron making process and (ii) Study of Iron- Carbide diagram

### **1.2.7.2 Properties and application of material used in machinery on board ships** (2 hours)

Instructors should refer to T7, T11 and T44 for this subject to (i) Explain the properties of materials and how these can be determined by simple tests (ii) Compare common non-metallic materials used at sea and explain their properties, applications and restrictions on usage and (iii) Examine common metallic materials used at sea, their applications, failure mechanisms, and methods to limit or reduce failures.

### **1.2.7.3 Engineering processes used in construction and repair** (4 hours)

Instructors should refer to T7, T11 and T44 for this subject to (i) Evaluate common fabrication techniques, including welding, forging, and casting and (ii) Assess common repair techniques.

### **1.2.7.4 Materials and Welding**

Instructors should refer to T7, T11 and T44 for this subject (i)Types of steel used (ii) Designation of material types (iii)Welding processes(iv)Electrodes(v)Forged, rolled, cast sections(vi)Edge preparation prior to welding (vii)Consideration of strength of welded sections(viii)Joining of different materials(ix)Construction and repairs and (x)Testing of weldments

## 1.2.8 NAVAL ARCHITECTURE AND SHIP CONSTRUCTION INCLUDING DAMAGE CONTROL (Refer to 4.1.1, 4.1.2 and 4.1.3)

## 1.3 OPERATION, SURVEILLANCE, PERFORMANCE ASSESSMENT AND MAINTAINING SAFETY OF PROPULSION PLANT AND AUXILIARY MACHINERY *Practical knowledge*

### 1.3.1 START UP AND SHUT DOWN MAIN AND AUXILIARY MACHINERY, INCLUDING ASSOCIATED SYSTEM

#### **1.3.1.1 Engine components** (18 hours)

Instructors should refer to V12, V70, V74, T1, T7, T11 and T17 for this subject to enable trainees (i)Interpret static and dynamic loads and stresses, identifying service limitations, of diesel engine components (ii)Evaluate different fabrication methods of diesel engine components(iii)Identify two and four stroke operating cycle forces, couples, and moments, relating these to design principles (iv)Explain out of balance

gas and inertia forces, couples, and moments, and relate these to flywheels, balance weights, and first/second order balancing, and hull vibration (v) Explain factors contributing to torsional vibration, and identify methods of minimizing or eliminating harmful effects of critical speeds (vi) Evaluate the calibration of pistons, cylinder liners, piston rings, bearings and crankshaft (vii) Specify alignment and adjustment criteria of Crankshafts, Chain drives, Gear drives, Integral thrust bearings and Crossheads (viii) Compile specified working clearances and limits of all bearings, sliding surfaces, and interference fits of a typical diesel engine, using engine builders' manuals.

#### **1.3.1.2 Engine Lubrication**

**(8 hours)**

Instructors should refer to V7, V8, V12, V70, V74, T7 and T11 for this subject to enable trainees (i) Identify diesel engine lubricant types, properties, and applications. (ii) Outline principles of diesel engine lubrication (iii) In relation to contamination and deterioration of diesel engine lubricants, discuss the sources, types, and effects of contamination, the causes, types, and effects of deterioration, typical testing and treatment methods, and interpret typical results of testing, giving appropriate actions which should be undertaken (iv) Describe, using diagrams, the distribution of lubricating oil to diesel engines, in particular the Guides and crosshead bearings of slow speed diesel engines, Top end bearings of medium speed engine, Bottom end bearing, Main bearings and Camshaft drives, showing direction of flow, typical clearances, and stating normal operating parameters.

#### **1.3.1.3 Fuel Injection**

**(12 hours)**

Instructors should refer to V5, T10, T20, T21 and T22 for this subject to enable trainees to (i) Explain why atomisation and penetration of fuel and the turbulence of air are essential to optimum combustion in a diesel engine (ii) State typical injection pressures and viscosities for different grades of fuel (iii) Describe how and why fuel pumps, camshafts, and injectors are altered for varying fuel types (iv) Describe, with the aid of simple sketches, the difference between constant and variable injection timing of fuel, showing materials, principal parts, methods of operation and adjustments of common types of fuel pump (v) Compare injection requirements for slow speed, medium speed, and high speed diesel engines, including pilot injection and pre-combustion chambers (vi) Identify common service faults, symptoms, and causes of combustion problems, specifying appropriate adjustments, including methods of fuel pump timing (vii) Summarise Occupational Health & Safety aspects of handling and testing fuel injection systems (viii) Explain, using relevant diagrams and stating normal operating parameters: (ix) Fuel valve cooling arrangement (x) Uni-fuel and dual-fuel systems (for high/medium viscosity fuel types) (xi) Discuss the atmospheric pollution aspects of diesel engine combustion, and give methods which reduce this pollution (especially SO<sub>x</sub> and NO<sub>x</sub> reduction).

#### **1.3.1.4 Scavenging and Supercharging**

**(10 hours)**

Instructors should refer to T10, T20, T21 and T22 for this subject to enable trainees to evaluate the need for scavenging in diesel engines, the methods of scavenging, the pressure charging methods, the working principles of turbochargers, cooling and lubrication of turbochargers, assessment of turbocharging, analyse typical faults and appropriate actions to be undertaken with defective or damaged turbochargers.

#### **1.3.1.5 Starting and Reversing**

**(8 hours)**

Instructors should refer to T10, T20, T21 and T22 for starting procedures of diesel engines for power generation, propulsion, and emergency use, starting and manoeuvring requirements/sequences for direct coupled reversible and geared propulsion diesel engines, for fixed and controllable pitch propeller applications, typical manoeuvring and reversing systems for propulsion diesel engines, compare different methods of reversing direct coupled propulsion diesel engines, identify common faults and identify appropriate actions to be undertaken with typical diesel engine starting and manoeuvring systems, compare the different methods of utilising diesel engines for ship propulsion, including: Direct coupled, reversible slow and medium speed engines, Clutched and geared reversible and unidirectional medium speed engines with a fixed pitch propeller, Clutched and geared reversible and unidirectional medium speed engines with a controllable pitch propeller and Diesel electric drive.

#### **1.3.1.6 Cooling systems**

**(4 hours)**

Instructors should refer to V69, T10, T20, T21 and T22 for this subject to enable trainees to : (i)Analyse the problems that may arise in cooling water spaces of diesel engines (ii)Evaluate common methods of diesel engine cooling water treatment (iii)State the importance of maintaining diesel engine thermal efficiency and evaluate thermal loads on engine components (iv)Justify cooling media selection and state the advantages and disadvantages of various diesel cooling methods (v)Evaluate the tests used in the control of diesel engine cooling water treatment (vi)Enumerate the normal operating limits for diesel engine cooling water treatment (vii)Interpret the implications of out of limit readings from water treatment tests and state the corrective procedures which should be undertaken (viii)Itemise the sources and types of contamination of diesel engine cooling water and explain the effects of these contaminations on the reserves of treatment chemicals (ix)Compare the procedures which may be used to counter contamination of diesel engine cooling water and (x)Explain, using relevant diagrams and stating normal operating parameters, typical methods of cooling of Medium and slow speed diesel engine pistons, Exhaust valves, Cylinders, Turbochargers and Cylinder heads.

#### **1.3.1.7 Diesel Engine Control and Safety**

**(4 hours)**

Instructors should refer to V9, V53, T10, T46 and T47 for this subject to enable trainees understand the following safety aspects (i) With respect to waste heat units: explain the design and operational factors that contribute to fires in waste heat units, generation of soot and hydrogen fires, possible consequences of such fires, identify

routine cleaning and inspection criteria, identify symptoms of a fire. appropriate actions to be undertaken upon fire detection in order to contain/extinguish the fire, and identify the risks of isolating a waste heat unit (ii) With respect to scavenge fires: explain the factors that contribute to a fire in the scavenge chamber of a diesel engine, explain the possible consequences of such fires, specify detection, protection, and extinguishing devices, identify routine cleaning and inspection criteria, identify symptoms of a fire, and give appropriate actions to be undertaken upon fire detection in order to contain/extinguish the fire (iii)With respect to starting air lines identify principles of explosive mixtures, describe how an air line explosion can occur, explain the possible consequences of such an explosion, identify routine evaluation criteria of starting air systems for minimising/avoiding an explosion, and state how the risk of explosion may be minimised/avoided by protection devices. (iv)Diesel engine crankcases and gearboxes(v)Evaluate the causes and consequences of diesel engine overspeed, and give procedures which must be undertaken in the event of such an occurrence and (vi)Explain, using diagrams, the operating principles of Oil mist detectors, giving testing procedures ,Explosion relief doors ,Crankcase breathers and Crankcase extraction fans.

#### **1.3.1.8 Diesel Engine Emergency operation (2 hours)**

Instructors should refer to V9, V53, T10, T46 and T47 for this subject to enable trainee explain emergency procedures for maneuvering for diesel engines and maneuvering with defective clutches.

#### **1.3.1.9 Multi-engine Propulsion Arrangement (2 hours)**

Instructors should refer to T7, T11 and T15 for this subject to enable trainees (i)Explain the need for changing the output speed of prime movers (ii) Define gearing concepts, and explain the advantages and disadvantages of utilising gearing to change prime mover output speed, involute gearing, spur and helical gears (iii) Assess the need for disengaging prime movers from drive lines (iv) Identify common types of clutches and couplings used with prime movers and (v) Outline maintenance procedures associated with clutches.

#### **1.3.1.10 Air compressors and compressed air systems (3 hours)**

Instructors should refer to T7 and T11 for this subject to enable trainee (i)Examine the functions and operation of all components including fittings and safety devices of air compressors and compressed air systems (ii)Evaluate the effects of common operational faults of single and multi-stage air compressors, including: leaking valves, leaking piston rings, blocked filters, blocked coolers (iii)Explain the reasons and the effects of high levels of oil or water in compressed air 9iv)Explain the effects of operating air compressors with synthetic lubricating oils compared to operating with mineral lubricating oils. And (v) Describe a procedure for inspecting and maintaining air receivers and their fittings.

#### **1.3.1.11 Hydraulic power system**

**(6 hours)**

Instructors should refer to V11, V77 and T15 for this subject to enable trainee Analyze functions and operation of all components including fittings and safety of devices of hydraulic power systems and Interpret symptoms, effects, and remedial actions for common faults in hydraulic power systems.

#### **1.3.1.12 Types of auxiliary boilers**

**(9 hours)**

Instructors should refer to V3, V10, V74, T7, T8, T11, T15, T38 and T42 for this subject to enable trainees (i)Examine typical boiler types illustrating cross sections, attachments and locations of all fittings, mountings, scantlings and methods of achieving water circulation and gas flow (ii)Distinguish the material requirements for boiler components (iii)Explain the construction of typical types of boilers (iv)Explain functions and operation of all boiler components including fittings and safety devices (v)Illustrate a typical boiler fuel system and its components (vi)Examine the operation and maintenance procedures of boiler fuel systems (vii) Analyze the combustion process, its monitoring system, and requirements for proper combustion (viii) Evaluate common types of burners and distinguish how atomization and subsequent combustion is achieved and (ix) Identify the protection devices, alarms, and shutdowns used in combustion control and fuel systems, and analyze their importance and methods of operation.

#### **1.3.1.13 Auxiliary steam system**

**(2 hours)**

Instructors should refer to V3, V10, V74, T7, T8, T11, T15, T38 and T42 for this subject to enable trainees (i) Illustrate a typical auxiliary steam system, showing the location and purpose of all components (ii)Develop a heat energy balance for an auxiliary steam system (iii)Distinguish the material requirements for auxiliary steam system components (iv)Examine the construction and operation of typical auxiliary steam system components (v)Explain the reasons for operating the auxiliary steam plant and its systems at nominated temperatures and pressures, and the effects of departing from these parameters (vi)Analyze the symptoms of faults in steam traps, hot wells, de-aerators and condensers and (vii)Analyze the requirements for contamination prevention between systems.

#### **1.3.1.14 Safety valves**

**(4 hours)**

Instructors should refer to V3, V10, V74, T7,T8, T11, T15, T38 and T42 for this subject to enable trainees (i)Analyze the requirements for steam safety valves (ii)Analyze the design formulae used for steam safety valves (iii)Differentiate between common types of boiler safety valves in use and explain how they are classified in terms of valve lift (iv)Distinguish the materials of construction of safety valves (v)Analyze operational problems that can occur with safety valves (vi)Examine how a safety valve is inspected and overhauled, giving common defects and areas of importance when inspecting (vii)Formulate a procedure for setting safety valves, and examine the precautions necessary when testing safety valves on boilers and waste heat unit.

#### **1.3.1.15 Boiler water levels**

**(6 hours)**

Instructors should refer to V3, V10, V74, T7,T8, T11, T15, T38 and T42 for this subject to enable trainees (i)Discuss requirements for boiler water level indicators (ii)Differentiate between common types of local boiler water level indicator in use, explaining their different methods of construction and operation (iii)Evaluate testing, maintenance and defect rectification procedures for local boiler water level indicators (iv)Differentiate between common types of remote boiler water level indicator in use, explaining their different methods of construction and operation and (v)Evaluate testing, maintenance and defect rectification procedures for remote boiler water level indicators.

#### **1.3.1.16 Use of Sea water in Boilers**

**(0.5 hour)**

Instructors should refer to V3, V10, V74, T7, T8, T11, T15, T38 and T42 for this subject to enable trainees explain the reasons and the effects of using sea water in Boilers.

#### **1.3.1.17 Use of Fresh Water in Boilers**

**(0.5 hour)**

Instructors should refer to V3, V10, V74, T7, T8, T11, T15, T38 and T42 for this subject to enable trainees (i) Analyze the different types of impurities present in boiler, feed and make up water (ii) Explain how salts are precipitated from boiler and feed water, and the consequences of this precipitation and (iii) Explain how metal is corroded in the boiler and feed system.

#### **1.3.1.18 Boiler Water Testing**

**(3 hours)**

Instructors should refer to V3, V10, V74, T7, T8, T11, T15, T38 and T42 for this subject to enable trainees (i) Define pH and explain how it is measured and controlled (ii) Evaluate the tests used in the control of boiler and feed water treatment and (iii) Interpret the implications of out of limit readings from water treatment tests and state the corrective procedures which should be undertaken.

#### **1.3.1.19 Boiler Water Treatment**

**(9 hours)**

Instructors should refer to V3, V10, V74, T7, T8, T11, T15, T38 and T42 for this subject to enable trainees (i) Evaluate common methods of boiler feed and make up water treatment. (ii)Show how oxygen is eliminated in high pressure boilers (iii) Enumerate the normal and maximum operating limits for boiler and feed water treatment (iv) Itemise the sources and types of contamination of boiler, feed, and make up water and explain the effects of these contaminations on the reserves of treatment chemicals and (v) Compare the procedures which may be used to counter contamination of boiler, feed, and make up water.

#### **1.3.1.20 Auxiliary Steam turbines**

**(9 hours)**

Instructors should refer to V3, V10, V74, T7, T8, T11, T15, T38 and T42 for this subject to enable trainees(i)Analyze the types, uses, and methods of construction of auxiliary steam turbines in use at sea (ii)Examine the typical operating conditions, including temperatures and pressures, of auxiliary steam turbines (iii)Identify the materials used in auxiliary steam turbines and ancillary equipment (iv)Examine typical operational problems



associated with auxiliary steam turbine plants, the symptoms, effects, and possible remedies of these faults(v)Explain the processes of warming through and shutting down auxiliary steam turbine plants and (vi)Outline the maintenance associated with optimum performance of an auxiliary steam turbine plant.

#### **1.3.1.21 Boiler defects**

**(3 hours)**

Instructors should refer to V3, V10, V74, T7,T8, T11, T15, T38 and T42 for this subject to enable trainees(i)Identify the possible defects which may occur in a boiler, gas and water side, giving their location, nature, and effects (ii)Outline procedures commonly employed to rectify defects in boilers, and explain the limitations of such repairs and (iii)Enumerate procedures for leak detection in boilers and other steam system components, and explain the remedial actions which may be undertaken

#### **1.3.1.22 Boiler and steam turbine survey and repairs**

**(6 hours)**

Instructors should refer to V3, V10, V74, T7, T8, T11, T15, T38 and T42 for this subject to enable trainees (i) Examine the need for surveying auxiliary boilers, steam turbines and other components of auxiliary steam systems (ii) Outline survey requirements for auxiliary boilers, steam turbines and other components of auxiliary steam systems and (iii) Outline the procedures for shutting down, isolating and opening up an auxiliary boiler for inspection or during an emergency.

#### **1.3.1.23 Evaporators**

**(6 hours)**

Instructors should refer to V3, V10, V74, T7, T8, T11, T15, T38 and T42 for this subject to enable trainees compare operation, performance, problems and applications of common fresh water generation plants used at sea and evaluate the need for treatment of evaporator water, and assess methods of fresh water generation plant water treatment.

#### **1.3.1.24 Thermal fluid heating system**

**(3 hours)**

Instructors should refer to V3, V10, V74, T7, T8, T11, T15, T38 and T42 for this subject to enable trainees examine typical thermal fluid heating systems and explain the advantages and disadvantages of these systems, compare with conventional steam plant, the locations and functions of all components, fittings, and safety devices used in thermal fluid systems and analyze the properties of thermal fluids used, effects of contamination, and methods of testing the fluid

### **1.3.2 OPERATING LIMITS OF PROPULSION PLANTS**

Refer to 1.2.3

### 1.3.3 THE EFFICIENT OPERATION, SURVEILLANCE, PERFORMANCE ASSESSMENT AND MAINTAINING SAFETY OF PROPULSION PLANT AND AUXILIARY MACHINERY

#### **1.3.3.1 Diesel engines**

**(10 hours)**

Instructors should refer to V1, V9, V12, T10, T20, T21 and T22 for to enable trainees understand (i)Indicator and draw diagrams , calculation of power, efficiency .Also estimation of power of engine using engine parameters like fuel index, engine RPM (ii)Detection of fault from indicator diagrams and (iii)Engine condition monitoring and evaluation Instructors would find considerable benefit from reading a wide range of books on marine engineering and technical papers. Engine -manufacturers provide their customers with manuals which give instructions on the operation and maintenance of their engines. Such manuals are of immense value to both instructors and trainees. Every effort should be made to obtain manuals appropriate to the type of machinery which the trainees are likely to experience.

Currently, low-speed diesel engines are built mainly by three manufacturers - MAN B&W, Wartsila Sulzer and Mitsubishi. The former two share the bulk of new tonnage and the latter is largely confined to Japanese-built ships.

### 1.3.4 FUNCTIONS AND MECHANISM OF AUTOMATIC CONTROL FOR MAIN ENGINE

Refer to 2.1.2.2

### 1.3.5 FUNCTIONS AND MECHANISM OF AUTOMATIC CONTROL FOR AUXILIARY MACHINERY INCLUDING BUT NOT LIMITED TO:

#### **1.3.5.1 Generator distribution system**

Refer to 2.1.2.3

#### **1.3.5.2 Steam boiler**

Refer to 2.1.2.4

#### **1.3.5.3 Oil purifier**

**(3 hours)**

Instructors should refer to V87, T9 and T46 for this subject to enable trainees understand Automation, monitoring and alarms, temperature control, automatic start and desludging, detection of water content.

#### **1.3.5.4 Refrigeration and air conditioning system**

**(3 hours)**

Instructors should refer to V76, T7, T11 and T49 for this subject to enable trainees understand (i) Automation, monitoring and alarms in refrigeration system (ii) Capacity control may be used on board for refrigeration compressor and (iii)Automatic control of steam spray for accommodation air conditioning heating system

#### **1.3.5.5 Pumping and piping system**

**(1 hour)**

Instructors should refer to V79, T7 and T11 for this subject to deal with Pumping and piping system. Explain with examples of piping system on different types of vessels such as bulk carriers, tankers and other vessels.

#### **1.3.5.6 Steering gear system**

**(2 hour)**

Instructors should refer to V68, V86, T7 and T11 for this subject to deal with topics on Autopilot system and regaining of steering capability in case of single failure of the hydraulic system

#### **1.3.5.7 Cargo-handling equipment and deck machinery**

**(1 hour)**

Instructors should refer to T7, T11 and T15 for this subject to deal with topics on (i) Self-tensioning mooring winches (ii) Automatic shut down of cargo pumping on abnormal operating conditions of inert gas system on board tankers and (iii) Automatic shut down of cargo pumping / loading on tankers and gas carriers.

### **1.4 MANAGE FUEL, LUBRICATION AND BALLAST OPERATIONS**

#### **1.4.1 OPERATION AND MAINTENANCE OF MACHINERY, INCLUDING PUMPS AND PUMPING SYSTEM**

##### **1.4.1.1 Ballast**

**(2 hours)**

Instructors should refer to V57, V60, R39, R40, T7 and T11 for this subject to (i) Describe procedures for evaluating pumps, ejectors, and pumping systems including ship side valves, explain methods of identifying problems which affect performance, and identify common faults and evaluate methods of assessment (ii) Illustrate the operation of self priming systems as used on ballast or cargo pumping arrangements (iii) Explain the main causes of corrosion in sea water systems and the region's most affected and (iv) Compare corrosion and marine growth prevention systems used for pumps and pumping systems, including impressed current, sacrificial anodes, chemical injection, special coatings, chlorination, and special materials.

Instructors should also explain to the trainees

#### **International Convention for the Control and Management of Ships' Ballast Water and Sediments (BWM)**

The Convention aims to prevent the potentially devastating effects of the spread of harmful aquatic organisms carried by ships' ballast water from one region to another.

The Convention will require all ships to implement a Ballast Water and Sediments Management Plan. All ships will have to carry a Ballast Water Record Book and will be required to carry out ballast water management procedures to a given standard. Existing ships will be required to do the same, but after a phase-in period

Instructors are advised to refer to the IMO web site for details.  
[www.imo.org](http://www.imo.org).

#### **1.4.1.2 Bilge** **(2 hours)**

Instructors should refer to T7 and T11 for this subject to (i) Describe procedures for evaluating pumps, ejectors, and pumping systems including ship side valves, explain methods of identifying problems which affect performance, and identify common faults and evaluate methods of assessment (ii) Illustrate the operation of self priming systems as used on bilge pumping arrangements (iii) Explains the purpose and procedure for using bilge injection.

#### **1.4.1.3 Fire Main** **(2 hours)**

Instructors should refer to T7 and T11 for this subject to (i) Describes the number and source of supply to the fire main for the given ship (ii) Explain how and when fire pumps should be tested (iii) Describes the uses to which a fire main can be put and (iv) Explain the purpose of the fittings on a fire main

#### **1.4.1.4 Prevention of Pollution of the Sea by Oil** **(4 hours)**

Instructors should refer to T7 and T11 for this subject which (i) Describes in principle how bilge and ballast water are discharged (ii) Lists the precautions to be taken when bunkering fuel oil and lubricating oil (iii) Describes the requirements for oily water separators (iv) Explains how the mode and type of pump used affects the contamination of oily water (v) Explains how the temperature, relative density and size of oil particles affect the separation process (vi) Explains the principles of the operation of a two stage and three stage automatic oily water separator (v) Explains why and where pressure relief devices are fitted to a separator (vi) Describes the function of a coalesce (vii) Explains the principles and purpose of a separator probe (viii) Describes how the automatic valve is controlled and operated (ix) Lists the safeguards in an oily water separator system and (x) Describes the automatic cleaning of an oily water separator.

#### **1.4.1.5 Sewage and sludge** **(4 hours)**

Instructors should refer to T7 and T11 for this subject which (i) Describes a sewage retention system (ii) Explains why vacuum transportation systems are used (iii) Describes the process where a comminutor and treatment with chlorine are used (iv) Describes the processes in a biological treatment plant (v) Explains how the sludge from a biological treatment plant is disposed of (vi) Explains why biological treatment should be kept working continuously (vii) Names the contaminants which

would impair the treatment process (viii)Describes the operation of chemical treatment plants (ix)Lists the waste materials that can be incinerated and (x)Explains how liquid and solid waste are prepared for combustion in an incinerator

Reference to this training outcome, Annex IV has entered into force and many ships are equipped to comply in order to satisfy port regulations.

## **Chief Engineer Officer and Second Engineer Officer**

### **Function 2:**

## **Electrical, Electronic and Control Engineering at the Management Level**

## PART B2: COURSE OUTLINE

Knowledge, understanding and proficiency		Total hours for each topic	Total hours for each subject area of Required performance
<b>Competence:</b>			
<b>2.1</b>	<b>MANAGE OPERATION OF ELECTRICAL AND ELECTRONIC CONTROL EQUIPMENT <i>THEORETICAL KNOWLEDGE</i></b>		
<b>2.1.1</b>	<b>MARINE ELECTROTECHNOLOGY, ELECTRONICS, POWER ELECTRONICS, AUTOMATIC CONTROL ENGINEERING AND SAFETY DEVICES.</b>		
.1	Marine Electrotechnology	40	
.2	Electronics, Power Electronics	30	
.3	Automatic Control Engineering and Safety devices	40	110
<b>2.1.2</b>	<b>DESIGN FEATURES AND SYSTEM CONFIGURATION OF AUTOMATIC CONTROL EQUIPMENT AND SAFETY DEVICES FOR THE FOLLOWING :</b>		
.1	General Requirements	2	
.2	Main Engine	20	
.3	Generator and distribution system	2	
.4	Steam boiler	2	26
<b>2.1.3</b>	<b>DESIGN FEATURES AND SYSTEM CONFIGURATION OF OPERATIONAL CONTROL EQUIPMENT FOR ELECTRICAL MOTORS</b>		
.1	Three phase A. C. motor	6	
.2	Three phase synchronous motors	4	
.3	Effect of varying frequency and voltage of A. C. motors	4	
.4	Motor control and protection	3	
.5	Insulated gate bipolar transistor (IGBT) motor speed control	4	
.6	Motor speed control by thyristors	2	
.7	Three phase generators	7	
.8	Three phase transformers	3	
.9	Distribution	4	
.10	Emergency power	3	40

<b>Knowledge, understanding and proficiency</b>		<b>Total hours for each topic</b>	<b>Total hours for each subject area of Required performance</b>
<b>2.1.4</b>	<b>DESIGN FEATURES OF HIGH-VOLTAGE INSTALLATIONS</b>		
.1	Design features of high-voltage installations	20	20
<b>2.1.5</b>	<b>FEATURES OF PNEUMATIC AND HYDRAULIC CONTROL EQUIPMENT</b>		
.1	Hydraulic control equipment	5	
.2	Pneumatic control equipment	5	10
<b>2.2</b>	<b>MANAGE TROUBLE SHOOTING RESTORATION OF ELECTRICAL AND ELECTRONIC CONTROL EQUIPMENT TO OPERATING CONDITION</b> <b><i>PRACTICAL KNOWLEDGE</i></b>		
<b>2.2.1</b>	<b>TROUBLE SHOOTING OF ELECTRICAL AND ELECTRONIC CONTROL EQUIPMENT</b>		
.1	Electrical safety	2	
.2	Test equipment	12	
.3	Interpretation of circuit symbols	12	
.4	Logical six step trouble shooting procedure	8	
.5	Generation	6	
.6	Prime mover electrical control	3	
.7	Main air circuit breaker	3	
.8	Protection of generators	4	
.9	Electrical distribution systems	2	
.10	Motors	4	
.11	Electrical survey requirements	4	
.12	Calibrate and adjust transmitters and controllers	3	
.13	Control system fault finding	3	66
<b>2.2.2</b>	<b>FUNCTION TEST OF ELECTRICAL, ELECTRONIC CONTROL EQUIPMENT AND SAFETY DEVICES</b>		
.1	Function test of electrical, electronic control equipment and safety devices	12	12



**2.2.3 TROUBLE SHOOTING OF MONITORING SYSTEMS**

.1	Test and calibration of sensors and transducers of monitoring system	12	12
----	--	----	----

**2.2.4 SOFTWARE VERSION CONTROL**

.1	Programmable logic controllers (PLC)	6	
.2	Microcontrollers	6	
.3	Digital techniques	8	20

**Total for Function 2: Electrical, electronic and control engineering at the management level 316**

## **PART C2: DETAILED TEACHING SYLLABUS**

### **COMPETENCE 2.1 MANAGE OPERATION OF ELECTRICAL AND ELECTRONIC CONTROL *THEORETICAL KNOWLEDGE***

#### **TRAINING OUTCOMES:**

Demonstrates a knowledge and understanding of:

#### **2.1 MANAGE OPERATION OF ELECTRICAL AND ELECTRONIC CONTROL *THEORETICAL KNOWLEDGE***

**2.1.1** MARINE ELECTROTECHNOLOGY, ELECTRONICS, POWER ELECTRONICS, AUTOMATIC CONTROL ENGINEERING AND SAFETY DEVICES.

**2.1.2** DESIGN FEATURES AND SYSTEM CONFIGURATION OF AUTOMATIC CONTROL EQUIPMENT AND SAFETY DEVICES FOR THE FOLLOWING :

**2.1.3** DESIGN FEATURES AND SYSTEM CONFIGURATION OF OPERATIONAL CONTROL EQUIPMENT FOR ELECTRICAL MOTORS.

**2.1.4** DESIGN FEATURES OF HIGH-VOLTAGE INSTALLATIONS

**2.1.5** FEATURES OF PNEUMATIC AND HYDRAULIC CONTROL EQUIPMENT

### **COMPETENCE 2.1 MANAGE OPERATION OF ELECTRICAL AND ELECTRONIC CONTROL *THEORETICAL KNOWLEDGE***

**2.1.1** MARINE ELECTROTECHNOLOGY, ELECTRONICS, POWER ELECTRONICS, AUTOMATIC CONTROL ENGINEERING AND SAFETY DEVICES

Required Performance:

#### **.1 Marine Electro-technology (40 hours )**

- Direct Current Circuits
  - Fundamental concepts: Ohm's Law
  - Kirchhoff's Law
  - Thevenin's Theorem
  - Resistors: energy, power, efficiency.
- Electrostatics and Capacitance
  - Charged bodies and electrostatic fields (concept)

- Capacitance and the capacitor
- Capacitors in series and parallel. Energy stored in a capacitor
- Types of capacitors
- Capacitor construction
- Dielectric strength
- Working voltage
- Time constant
  
- Electromagnetism and Induction
  - Magnetic field patterns
  - Electromagnetic fields around conductors, solenoids and toroids
  - Magnetic flux, flux density, permeability, magnetic field strength  
magneto motive force.
  - B/H curves
  - Reluctance
  - Series magnetic circuits
  - Hysteresis
  - Force on a conductor in a magnetic field
  - Induced e.m.f. in a conductor. Lenz's Law
  - Faraday's Law
  - Self Inductance
  - Inductors in series
  - Time constant
  - Mutual inductance
  - Coefficient of coupling.
  
- Alternating Current Theory
  - Simple alternating current generator and the sinusoidal waveform
  - Values of alternating current waveforms, instantaneous, peak, average, root mean square, cycle, frequency, period, amplitude, phase and form factor.
  - Graphical addition of waveforms
  - Appreciation of harmonics
  - Phasor representation
  - Kirchhoff's Laws
  - Polar notation
  - J notation. Inductance, capacitance, reactance and impedance
  - Power, power factor, skin effect.
  
- Single Phase Transformers
  - Principle of operation. Emf and transformer equations.
  - Transformer construction.
  - Transformer losses
  - Short circuit test
  - Open circuit test

- Impedance transformation.
  - Equivalent circuit
  - Auto transformer
  - Regulation
  - Instrument transformers.
- Three Phase Supply
    - Polyphase generation systems.
      - ❖ Three-phase alternator - phase differences and the usual colour coding
      - ❖ Graph showing the voltage variation over one cycle from a three-phase generator
      - ❖ Star Connection
      - ❖ Delta Connection
      - ❖ Power
  - Materials of conductors – single wire and multi-stranded
  - Commonly used insulation material
  - Effect of temperature, oxidation, fire, oil, seawater, acids and solvents on insulation materials
  - Sheathing of electric cables
  - Cable runs in machinery spaces, cargo holds and cold-storage chambers
  - Passing of cables through bulkheads and decks
  - Deck Machinery
  - Fail safe brake
  - Coil operated brake
  - Deck winches and capstans, windlass and deck cranes
  - Electrical Interference
  - Equipment susceptible to electric interference
  - Common sources of interference
  - Method of suppression of interference

**.2 Electronics, Power Electronics (30 hours)**

- Semiconductor Devices
  - Uni-junction transistor
  - The Bipolar transistor, operation and characteristics, bias circuits, AC and DC current gain, data sheets.
  - Field Effect Transistors, operation. Thyristors, SCRs, GTOs, DIACs and TRIACs operation and characteristics.
  - Insulated gate bipolar transistor (IGBT)
  - Snubber circuits, commutation, data sheets.
  - Device applications in electronic control, surveillance and recording systems, power supplies, rectification, smoothing circuits, stabilisation, switching, amplification, pulse shaping, clipping and clamping.

- Integrated Circuits
  - Ideal operational amplifier, characteristics, types, mounting methods and markings, advantages of ICs.
  - Practical operational amplifier, circuit configurations,
  - CMRR, instrumentation amplifier, 4-20mA circuit.
  - Voltage regulators, multivibrators.
  - IC applications and common circuits. Data sheets.
- Electronic Fault Diagnosis
  - Interpretation and use of electronic systems and subsystem circuit diagrams, operation and maintenance manuals.
  - Electronic test equipment, method of DMM display.
  - Use of CRO as a testing and display instrument.
  - Analysis of measurement and test result on components and circuits.
  - Methods of fault detection.

**.3 Automatic Control Engineering and safety devices. (40 hours)**

- Introduction
  - Open and closed control loops
  - Process control.
  - Essential components in process control loops.
- Sensors and transmitters
  - Resistance temperature devices.
  - Thermocouples. Flow and pressure measurement.
  - Level measurement.
  - Ambient temperature compensation.
  - Viscosity measurement.
  - Torque measurement.
  - Force balance transmitters.
  - Oil/water interface and oil in water monitoring.
  - The pneumatic flapper/nozzle system.
  - Pneumatic 20 – 100 kPa, analogue 4 to 20 mA signals, Pneumatic pilot relays.
  - Control air supply.
  - Operational amplifiers.
  - Electrical supply.
- Controllers and Basic Control Theory
  - Disturbances and time delays and means to reduce them.
  - Two step, proportional, integral, and derivative control actions.
- Final Control Elements
  - Diaphragm operated control valves.
  - Flow/lift characteristics of control valves.

- Control valve actuators and positioners. "Fail - safe", "fail - set" strategies.
- Wax element valves.
- Electrically operated valves.
  
- Control Loop Analysis
  - Temperature control systems.
  - Level control systems.
  - Pressure control systems.
  - Split range and cascade control.
  - Single, two and three element control.
  
- Governors
  - Need for governors. Governor terms, concepts and operation.
  - Hydraulic governors. Digital governors, Power sharing.
  - Governing systems.

#### 2.1.2 DESIGN FEATURES AND SYSTEM CONFIGURATION OF AUTOMATIC CONTROL EQUIPMENT AND SAFETY DEVICES FOR THE FOLLOWING:

Required Performance:

##### **.1 General Requirements (2 hours)**

- Electrical equipment designed for land use is often not suitable for use in ships
- As far as possible, all materials should be non-flammable explains where flame retardant materials may be used
- Meaning of the term flame retardant
- Angles of heel and trim at which machinery should be capable of operating
- Effect of temperature changes on:
  - Electromagnetic devices
  - Generator voltage
- Common maximum temperatures of air and sea water used for design purposes
- Axis of a rotating machine should not be placed athwart ships unless so designed.
- Need to periodically check the security of all electrical connections
- Requirements regarding the provision of electrical power and lighting for normal operation and for an emergency

##### **.2 Main Engine (20 hours)**

- Control Theory
  - Changing set points.
  - Basic control system design.

- First order and second order systems.
- Transfer Functions.
- Control system stability.
- Natural frequency and control systems.
- Time lag and time constant.
- System response.
  
- Tuning
  - System response.
  - Control loop tuning.
  - Ziegler-Nichols, Cohen-Coon tuning methods
  
- Signal Transmission Systems
  - Digital communication bus and fibre optic signal transmission systems
  
- Final Control Elements
  - Control valve trim.
  - Selecting control valves and their actuators.
  - Valve sizing
  
- Electronic PID Controllers
  - Single loop digital controllers.
  - Manual and automatic tuning of electronic controllers.
  
- Monitoring & Control Systems
  - Boiler water level control.
  - Advanced boiler combustion control.
  - Diesel engine cooling control
  - Main engine control for FP and CP propellers.
  - Alarm and monitoring systems.
  
- General requirements of automatic control equipment and safety devices
  - Monitoring system
  - Safety system
  - System independence
  - Local control
  - Failure mode and effect analysis
  - Power supply
  
- Remote control – Diesel propulsion
  - Control - electronic, electro-pneumatic, electro-hydraulic or pneumatic
  - Malfunctions – alarm, engine slow down, engine stop
  
- UMS Systems
  - Concept of Unattended Machinery Spaces (UMS).

- Requirements of UMS. Bridge control.
- Testing regime for UMS

**.3 Generator and distribution system (2 hours)**

- Instrumentation and Safety in Generator and Distribution system
- Auxiliary Diesel Generator Alarm and Shut Down
- Automatic Starting of Propulsion Auxiliaries

**.4 Steam boiler (2 hours)**

- Following failures will have alarms and display – feedwater high salinity, high water level, boiler pressure high and low, superheater outlet temperature high, fuel pump low outlet pressure, heavy fuel temperature high and low (or high and low viscosity), uptake high gas temperature, control system power failure, atomisation steam / air pressure low
- Following failures will have alarms, display and automatic shutdown of boiler – low water level, supply air pressure failure, ignition or flame failure.

**2.1.3 DESIGN FEATURES AND SYSTEM CONFIGURATION OF OPERATIONAL CONTROL EQUIPMENT FOR ELECTRICAL MOTORS, AND DESIGN FEATURES OF HIGH-VOLTAGE INSTALLATIONS**

Required Performance:

**.1 Three Phase A.C. Motors (6 hours)**

- Construction, principle of operation of 3-phase induction motors.
- Design features of star and delta motors.
- Starting, speed controlling and braking methods of 3-phase induction motors.
- Load-torque characteristics and protection.

**.2 Three Phase Synchronous Motors (4 hours)**

- Construction. Principle of operation. Load characteristics.
- Power factor improvement with synchronous motors.

**.3 Effect of varying frequency and voltage of A.C. Motors (4 hours)**

- Speed
- Temperature
- Torque
- Power output
- Starting time, current



- .4 Motor control and protection (3 hours)**
- D. C. motors
  - A. C. motors
- .5 Insulated Gate Bipolar Transistor (IGBT) motor speed control (4 hours)**
- Gate driving characteristics with high current
  - High frequency, high current switch
  - Advantages of IGBT in varying motor speed control
- .6 Motor speed control by Thyristors (2 hours)**
- Application of thyristors in motor speed control
- .7 Three Phase Generators (7 hours)**
- Construction. Salient and cylindrical rotor types.
  - Shaft generators.
  - Excitation methods.
  - Automatic voltage regulation.
  - Synchronisation.
  - Parallel operation.
  - Generator trouble shooting.
- .8 Three Phase Transformers (3 hours)**
- Construction Polarity
  - Configurations in Star and Delta combinations.
  - Open delta configuration.
- .9 Distribution (4 hours)**
- Main switchboard construction and configuration.
  - Short circuit protection - fuses, main circuit breakers.
  - The generator air circuit breaker.
  - Protection co-ordination.
  - Distribution configuration.
  - Electrical equipment for tankers and hazardous areas and safety systems.
- .10 Emergency Power (3 hours)**
- Automatic starting arrangements for the emergency generator.
  - Emergency power requirements.
  - Essential and non essential circuits.
  - Batteries.

## 2.1.4 DESIGN FEATURES OF HIGH-VOLTAGE INSTALLATIONS

Required Performance:

### **.1 Design features of high-voltage installations (20 hours)**

- Generation and distribution of high voltage on ships
- Electric propulsion system
- Synchro-convertors and cyclo-convertors
- Functional, operational and safety requirements for a marine high-voltage system
- Assigning qualified personnel to carry out maintenance and repair of high-voltage switchgear of various types
- High voltage system advantages
- Advantages of an insulated system
- High voltage circuit breakers
- High voltage cable
- High voltage fuses
- Remedial action necessary during faults in a high-voltage system
- Switching strategy for isolating components of a high-voltage system
- Selection of suitable apparatus for isolation and testing of high-voltage equipment
- Switching and isolation procedure on a marine high-voltage system, complete with safety documentation
- Performance of insulation resistance and polarization index on high-voltage equipment

## 2.1.5 FEATURES OF PNEUMATIC AND HYDRAULIC CONTROL EQUIPMENT

Required Performance:

### **.1 Hydraulic Control Equipments (5 hours)**

- System components, Hydraulic Circuits, Hydraulic System Fitting & Maintenance.

### **.2 Pneumatic Control Equipment (5 hours)**

- Fluids, Pneumatic Circuits, Pneumatic System Fitting & Maintenance Components and Trouble shooting

**COMPETENCE 2.2    MANAGE    TROUBLE    SHOOTING    RESTORATION    OF  
ELECTRICAL AND ELECTRONIC CONTROL EQUIPMENT TO  
OPERATING CONDITION *PRACTICAL KNOWLEDGE***

TRAINING OUTCOME:

Demonstrates a knowledge and understanding of:

**2.2.1    TROUBLE SHOOTING OF ELECTRICAL AND ELECTRONIC CONTROL  
EQUIPMENT.**

**2.2.2    FUNCTION TEST OF ELECTRICAL, ELECTRONIC CONTROL EQUIPMENT  
AND SAFETY DEVICES**

**2.2.3    TROUBLE SHOOTING OF MONITORING SYSTEMS**

**2.2.4    SOFTWARE VERSION CONTROL**

**COMPETENCE 2.2 MANAGE TROUBLE SHOOTING RESTORATION OF ELECTRICAL AND ELECTRONIC CONTROL EQUIPMENT TO OPERATING CONDITION PRACTICAL KNOWLEDGE EQUIPMENT**

**2.2.1 TROUBLE SHOOTING OF ELECTRICAL AND ELECTRONIC CONTROL EQUIPMENT**

Required Performance:

- .1 Electrical Safety (2 hours)**
  - Safety procedures to be adopted when working on electrical installations.
  - The effects of electric current on the human body.
  
- .2 Test Equipment (12 hours)**
  - Practical use of Meggers, multimeters and CRO.
  - Care and precautions for carrying out open, short and insulation measurement test
  
- .3 Interpretation of Circuit Symbols (12 hours)**
  - Circuit components, functional description.
  - Construction of simple electrical circuits using relays, timers, contactors and other components.
  
- .4 Logical six step troubleshooting procedure (8 hours)**
  - Symptom identification
  - Symptom analysis
  - Listing of probable faulty function
  - Localising of faulty function
  - Localising trouble to circuit
  - Failure analysis
  
- .5 Generation (6 hours)**
  - Alternators, excitation methods, AVR and auto-synchronising equipment.
  - Manual load sharing and modern load sharing equipment.
  
- .6 Prime Mover Electrical Controls (3 hours)**
  - Description, identification and operation of control components of the prime mover for the alternator.
  
- .7 Main Air Circuit Breaker (3 hours)**
  - Operating and servicing.

- .8 Protection of Generators (4 hours)**
- Instrumentation and control associated with the electrical protection of the generating plant.
  - Routine maintenance.
- .9 Electrical Distribution Systems (2 hours)**
- General layout, problems encountered using neutral configuration.
  - Fault tracing in distribution circuits
- .10 Motors (4 hours)**
- Review of motor features and starting arrangements. Trouble shooting.
  - Speed control of a.c. motors using solid state devices. Soft starters.
- .11 Electrical Survey Requirements (4 hours)**
- Conducting tests to the requirements of survey.
- .12 Calibrate & Adjust Transmitters & Controllers (3 hours)**
- Differential pressure transmitter calibration.
  - Electronic temperature transmitter calibration.
  - The operation of a PID controller.
  - Tuning a PID controller.
  - Governors and controllable pitch propeller control.
  - Tests, faults, and solutions.
- .13 Control System Fault Finding (3 hours)**
- Fault finding methods.
  - Governor faults.
  - Evaluation and rectification of common control systems.
  - Testing alarm and monitoring systems.
  - Electric power supply for control systems.

#### **2.2.2 FUNCTION TEST OF ELECTRICAL, ELECTRONIC CONTROL EQUIPMENT AND SAFETY DEVICES**

Required Performance:

- .1 Function test of electrical, electronic control equipment and safety devices (12 hours)**
- Function test Over Current Relay (OCR)
  - Function test Relays and magnetic contactors
  - Function test Timers

- Function test Fuses
- Function test MCCB
- Function test ACB
- Function test Diodes
- Function test Silicon Controlled Rectifier (SCR)
- Function test Temperature, Pressure and Level transmitters:
- Function test Overspeed Protection Devices
- Function test Flame Scanners
- Function test Fire Detecting System

### 2.2.3 TROUBLESHOOTING OF MONITORING SYSTEMS

Required Performance:

#### **.1 Test and calibrations of sensors and transducers of monitoring system (12 hours)**

- Testing and calibration of pressure sensor and transducer
- Testing and calibration of temperature sensor and transducer
- Testing and calibration of flow sensor and transducer
- Testing and calibration of level sensor and transducer
- Testing and calibration of tachometer sensor and transducer
- Testing and calibration of viscometer sensor and transducer

### 2.2.4 SOFTWARE VERSION CONTROL

Required Performance:

#### **.1 Programmable logic controllers (PLC) (6 hours)**

- Basics of PLC operation
- Comparison between hard-wired and programmable control operation
- Advantages of PLCs
- Binary number conversion
- Digital logic gates and its practical application
- Inputs and output modules and configuration of PLCs
- Understanding of ladder logic and PLCs programming
- Human Machine Interface (HMI) and alteration of parameters in the programme
- Basic software version and control of access.
- Maintenance of Electronic Control Equipment and PLC Controlled processes
- Checking the programme validity and faultfinding and restoration of process with the help of PLCs

#### **.2 Microcontrollers (6 hours)**

- Introduction to microcontroller
- Basics of microcontroller
- Analog to digital convertor

- Digital interfaces
- Serial peripheral interface
- Communication with PC
- Code integration

### **.3 Digital Techniques**

**(8 hours)**

- Basic Logic gates and derived Logic gates. Boolean algebra.
- Principles and operation of digital integrated circuits (TTL and CMOS), adders, flip flops, registers, counters, multiplexers, encoders and decoders.
- Memories, RAM, ROM, PROM, EPROM, UV PROM
- Microprocessors, principles of operation, input/output functions, application in marine control systems, programs, alteration of values
- Single integrated circuit containing a processor core, memory, and programmable input/output peripherals.
- Program memory in the form of NOR flash or OTP ROM is also often included on chip and RAM.
- Microcontrollers- designed for embedded applications and real time response to events
- Typical input and output devices- switches, relays, solenoids, LEDs, radio frequency devices, and sensors for data such as temperature, humidity, light level etc.
- Description and use of General Purpose Input / Output pins (GPIO).
- Analog-to-digital converter (ADC)
- Digital-to-analog converter (DAC).

## **PART D2: INSTRUCTOR MANUAL**

### **Function 2: Electrical, Electronic and Control Engineering at the Management Level**

#### **■ General**

The instructor manual is included to provide additional information to instructors and teachers. It is designed to help in structuring and organizing this model course. It gives guidance on the material that is to be presented and the workshops that should be conducted during the course for marine environmental awareness. This manual reflects the views of the course developers with respect to methodology and organization as well as what they consider important in light of their experience as instructors of this course.

The guidance given is intended to give the instructor an operational baseline to develop a course that will meet the particular local requirements and to use the instructor's own experience and ideas.

Guidance is also provided in a booklet titled "Guidance on the implementation of IMO model courses" which includes a checklist for preparation of courses.

#### **■ Theory**

Theory can be taught as classroom lectures, preferably supported by video's, pictures and visual presentations.

Tips to present theory:

- Relate subjects to situations, which are familiar to participants
- Use enthusiastic presenters
- Ask questions, as this makes trainees think about the issue
- Encourage trainees to ask questions themselves and to interact during the lectures. Some points are more important than others and should be emphasized. To ensure that such points are remembered, they must be restated a number of times preferably in different words
- Reiterate things that are complex – don't worry about repeating information. Find more than one way to get a point across. If someone doesn't understand the first time, you can word it differently and it might be clear the second time (or the third time). Simple analogies are good. Ask if the audience understood the principle.

### **2.1 MANAGE OPERATION OF ELECTRICAL AND ELECTRONIC CONTROL EQUIPMENT THEORETICAL KNOWLEDGE**

#### **2.1.1 Marine Electrotechnology, Electronics, Power electronics, Automatic control engineering and Safety devices**



### 2.1.1.1 Marine Electro-technology

(40 hours)

Instructors should consult T5 and T6 for (i) Direct current circuits; (ii) Electrostatics and capacitance; (iii) Electromagnetism and induction; (iv) Alternating current theory and (v) Single phase transformers.

In Direct Current Circuits, replacing a network by its Thevenin equivalent can simplify the analysis of a complex circuit. It can be explained as shown below:

Any combination of batteries and resistances with two terminals can be replaced by a single voltage source and a single series resistor  $r$ . The value of  $e$  is the open circuit voltage at the terminals, and the value of  $r$  is  $e$  divided by the current with the terminals short circuited.

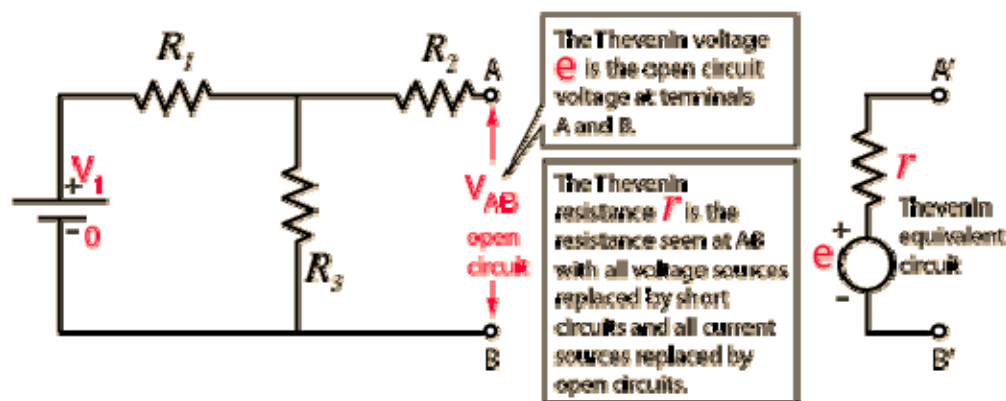

In the example above, the resistance  $R_2$  does not affect this voltage and the resistances  $R_1$  and  $R_3$  form a voltage divider, giving

$$e = \frac{V_1 R_3}{R_1 + R_3}$$

and the Thevenin resistance  $r$  used in Thevenin's Theorem is the resistance measured at terminals AB with all voltage sources replaced by short circuits and all current sources replaced by open circuits.

$$r = R_2 + \frac{R_1 R_3}{R_1 + R_3}$$

Instructors should consult T6, T13, T14, T15 and T23 for Three Phase Supply.

Instructors should consult T14 for (i) Materials of conductors – single wire and multi-stranded (ii) Commonly used insulation material (iii) Effect of temperature, oxidation, fire, oil, seawater, acids and solvents on insulation materials (iv) Sheathing of electric cables (v) Cable runs in machinery spaces, cargo holds and cold-storage chambers (vi) Passing of cables through bulkheads and decks (vii) Deck Machinery (viii) Fail safe brake (ix) Coil operated brake (x) Deck winches and capstans, windlass and deck cranes

Instructors should consult T58 (i) Electrical Interference (ii) Equipment susceptible to electric interference (iii) Common sources of interference (iv) Method of suppression of interference.

### **2.1.1.2 Electronics, Power Electronics**

**(30 ours)**

Instructors should consult T5, T6, T31, T32 and T51 for (i) Semiconductor Devices (ii) Uni-junction transistor (iii) The Bipolar transistor, operation and characteristics, bias circuits, AC and DC current gain, data sheets (iv) Field Effect Transistors, operation. Thyristors, SCRs, GTOs, DIACs and TRIACs operation and characteristics (v) Insulated gate bipolar transistor (IGBT) (vi) Snubber circuits, commutation, data sheets (vii) Device applications in electronic control, surveillance and recording systems, power supplies, rectification, smoothing circuits, stabilisation, switching, amplification, pulse shaping, clipping and clamping (viii) Integrated Circuits (ix) Ideal operational amplifier, characteristics, types, mounting methods and markings, advantages of ICs (x) Practical operational amplifier, circuit configurations (xi) CMRR, instrumentation amplifier, 4-20mA circuit (xii) Voltage regulators, multivibrators (xiii) IC applications and common circuits. Data sheets (xiv) Electronic Fault Diagnosis (xv) Interpretation and use of electronic systems and subsystem circuit diagrams, operation and maintenance manuals (xvi) Electronic test equipment, method of DMM display (xvii) Use of CRO as a testing and display instrument (xviii) Analysis of measurement and test result on components and circuits (xix) Methods of fault detection.

### **2.1.1.3 Automatic Control Engineering and safety devices**

**(40 hours)**

Instructors should consult T9, T46, T47 for (i) Introduction (ii) Sensors and transmitters (iii) Controllers and Basic Control Theory (iv) Final Control Elements (v) Control Loop Analysis

Instructors should consult T10, T15, T22 and B114 for Governors.

## **2.1.2 Design features and system configuration of automatic control equipment and safety devices**

### **2.1.2.1 General Requirements**

**(2 hours)**

Instructors should consult the website of a Classification society for following:

- Electrical equipment designed for land use is often not suitable for use in ships
- As far as possible, all materials should be non-flammable explains where flame retardant materials may be used
- Meaning of the term flame retardant
- Angles of heel and trim at which machinery should be capable of operating
- Effect of temperature changes on:
  - Electromagnetic devices
  - Generator voltage

- Common maximum temperatures of air and sea water used for design purposes
- Axis of a rotating machine should not be placed athwart ships unless so designed.
- Need to periodically check the security of all electrical connections
- Requirements regarding the provision of electrical power and lighting for normal operation and for an emergency

#### **2.1.2.2 Main Engine**

**(20 hours)**

Instructors should consult T60 and T46 and V9 for (i) Control Theory (ii) Tuning (iii) Signal Transmission Systems (iv) Digital communication bus and fibre optic signal transmission systems (v) Final Control Elements (vi) Electronic PID Controllers (vii) Monitoring & Control Systems

Instructors should consult the website of a Classification society for following:

- (i) General requirements of automatic control equipment and safety devices (ii) Remote control – Diesel propulsion and (iii) UMS Systems

#### **2.1.2.3 Generator and distribution system**

**(2 hours)**

Instructors should refer to T14, V14, V15 and V62 for following:

- Instrumentation and Safety in Generator and Distribution system
- Auxiliary Diesel Generator Alarm and Shut Down
- Automatic Starting of Propulsion Auxiliaries

#### **2.1.2.4 Steam boiler**

**(2 hours)**

Instructors should refer to T7, T8, T9, T11, T15 and T47 for following:

- Following failures will have alarms and display – feedwater high salinity, high water level, boiler pressure high and low, superheater outlet temperature high, fuel pump low outlet pressure, heavy fuel temperature high and low (or high and low viscosity), uptake high gas temperature, control system power failure, atomisation steam / air pressure low
- Following failures will have alarms, display and automatic shutdown of boiler – low water level, supply air pressure failure, ignition or flame failure.

### **2.1.3 Design features and system configuration of operational control equipment for electrical motors, and design features of high-voltage installations**

**2.1.3.1 Three Phase A.C. Motors (6 hours)**

Instructors should consult T5, T6 and T14 for (i) Construction, principle of operation of 3-phase induction motors (ii) Design features of star and delta motors (iii) Starting, speed controlling and braking methods of 3-phase induction motors (iv) Load-torque characteristics and protection.

**2.1.3.2 Three Phase Synchronous Motors (4 hours)**

Instructors should consult T5, T6 and V16 for (i) Construction, Principle of operation and Load characteristics and (ii) Power factor improvement with synchronous motors

**2.1.3.3 Effect of varying frequency and voltage of A.C. Motors (4 hours)**

Instructors should consult T58 for (i) Speed (ii) Temperature (iii) Torque (iv) Power output and (v) Starting time, current

**2.1.3.4 Motor control and protection (3 hours)**

Instructors should consult T5, T6 and T14 for (i) D. C. motors and (ii) A. C. motors

**2.1.3.5 Insulated Gate Bipolar Transistor (IGBT) motor speed control (4 hours)**

Instructors should consult T-60 for (i) Gate driving characteristics with high current (ii) High frequency, high current switch and (iii) Advantages of IGBT in varying motor speed control

**2.1.3.6 Motor speed control by Thyristors (2 hours)**

Instructors should consult T58 for Application of thyristors in motor speed control.

**2.1.3.7 Three Phase generators (7 hours)**

Instructors should consult T5, T6 and T14 for (i) Construction. Salient and cylindrical rotor types (ii) Shaft generators (iii) Excitation methods (iii) Automatic voltage regulation (iv) Synchronisation (v) Parallel operation and (vi) Generator trouble shooting.

**2.1.3.8 Three Phase Transformers (3 hours)**

Instructors should consult T14 for (i) Construction Polarity (ii) Configurations in Star and Delta combinations and (iii) Open delta configuration.

**2.1.3.9 Distribution (4 hours)**

Instructors should consult T14 and V15 for (i) Main switchboard construction and configuration (ii) Short circuit protection - fuses, main circuit breakers (iii) The generator air circuit breaker (iv) Protection co-ordination (v) Distribution configuration (vi) Electrical equipment for tankers and hazardous areas and safety systems.

### **2.1.3.10 Emergency Power**

**(3 hours)**

Instructors should consult T14 and V13 for (i) Automatic starting arrangements for the emergency generator (ii) Emergency power requirements (ii) Essential and non essential circuits and (iii) Batteries.

## **2.1.4 Design features of high-voltage installations**

### **2.1.4.1 Design features of high-voltage installations**

**(20 hours)**

Instructors should consult T14, T58 and V20 for (i) Generation and distribution of high voltage on ships (ii) Electric propulsion system (iii) Synchro-convertors and cyclo-convertors (iv) Functional, operational and safety requirements for a marine high-voltage system (v) Assigning qualified personnel to carry out maintenance and repair of high-voltage switchgear of various types (vi) High voltage system advantages (vii) Advantages of an insulated system (viii) High voltage circuit breakers (ix) High voltage cable (x) Remedial action necessary during faults in a high-voltage system (xi) Switching strategy for isolating components of a high-voltage system (xii) Selection of suitable apparatus for isolation and testing of high-voltage equipment (xiii) Switching and isolation procedure on a marine high-voltage system, complete with safety documentation (xiv) Performance of insulation resistance and polarization index on high-voltage equipment

## **2.1.5 Features of pneumatic and hydraulic control equipment**

### **2.1.5.1 Hydraulic Control Equipments**

**(5 hours)**

Instructors should consult T50, V11 and V77 for hydraulic control equipments. Directional control valves, control equipments, filter, regulators, lubricators should be adequately covered with reference to position control and velocity control systems.

### **2.1.5.2 Pneumatic Control Equipment**

**(5 hours)**

Instructors should consult T50 for pneumatic control equipment. Directional control valves, control equipments, filter, regulators, lubricators should be adequately covered with reference to position control and velocity control systems.

## **2.2 MANAGE TROUBLE SHOOTING RESTORATION OF ELECTRICAL AND ELECTRONIC CONTROL EQUIPMENT TO OPERATING CONDITION PRACTICAL KNOWLEDGE**

### **2.2.1 Trouble shooting of electrical and electronic control equipment**

#### **2.2.1.1 Electrical Safety**

**(2 hours)**

Instructors should consult T5, T6, T14 and V13 for (i) Safety procedures to be adopted when working on electrical installations and (ii) The effects of electric current on the human body.

### **2.2.1.2 Test Equipment**

**(12 hours)**

Instructors should consult T14, V17 and V19 for (i) Practical use of Meggers, multimeters and CRO and (ii) Care and precautions for carrying out open, short and insulation measurement test

### **2.2.1.3 Interpretation of Circuit Symbols**

**(12 hours)**

Instructors should consult T56 for (i) Circuit components and (ii) Construction of simple circuits. Practicals shall include numerous diagrams and interpretation by the candidates.

### **2.2.1.4 Logical six step troubleshooting procedure**

**(8 hours)**

Instructors should consult T55 for troubleshooting. Instructors should explain the six steps troubleshooting procedures (i) Symptom identification (ii) Symptom analysis (iii) Listing of probable faulty function (iv) Localising of faulty function (v) Localising trouble to circuit and (vi) Failure analysis

### **2.2.1.5 Generation**

**(6 hours)**

Instructors should consult T5, T6, T14 and V62 for Generation. AVR, Reactive loading of Alternators in parallel, excitation schemes, pilot excitation, residual excitation, 'flashing up' the alternator are topics that are covered in this section. Particular attention is paid to the alternators, the manner in which power is shared and the roles of the governor and the AVR in parallel operation. Power factor relation and some charts as follows may be made use of. The relation between KVA, KVAR, power factor should be explained by varying electrical loads on the system.

### **2.2.1.6 Prime Mover Electrical Controls**

**(3 hours)**

The electrical controls of prime movers include monitoring equipments viz. lubeoil pressure, cooling freshwater temperature, RPM, etc.

### **2.2.1.7 Main Air Circuit Breaker**

**(3 hours)**

Instructors should consult T14 and V15 for Main Air Circuit Breaker (ACB). The testing of ACB functions except the OCR can be done by ship's staff because current injectors are normally not available on board ships. Inspections of the ACB's shutdown circuits, reverse power etc are carried out by ship staff. The 'drawout' position of the ACB and the subsequent testing should be explained. SF6 breakers and Vacuum breakers are used in High Voltage installations.

### **2.2.1.8 Protection of Generators**

**(4 hours)**

The basic plant protection include

- Lubricating oil pressure low pressure
- Cooling Fresh water high temperature

- Overspeed
- Fuel oil leak off

Instructors should discuss that plant installation may have more than one sensor for the purpose of monitoring the above mentioned parameters. The difference between the alarm monitoring system and the shutdown system to be adequately highlighted. Calibration and testing routines are also to be explained.

#### **2.2.1.9 Electrical Distribution Systems (2 hours)**

Instructors to consult T14, V14 and V18 for Electrical distribution Systems. The need for 3 phase, three wire and insulated neutral system to be explained. Monitoring earth fault in 440V AC and lighting circuits to be explained. Earth lamp and insulation monitoring device for earth faults to be explained.

Need for early elimination of earth fault in 440V AC should be explained. Method of testing and removal of earth fault in 440V AC and lighting circuit to be explained. If it is possible, then a practical demonstration of above may be carried out.

#### **2.2.1.10 Motors (4 hours)**

Instructors to consult T58 for this subject.

#### **2.2.1.11 Electrical Survey Requirements (4 hours)**

Instructors to consult T14 and V19 for this subject.

#### **2.2.1.12 Calibrate & Adjust Transmitters and Controllers (3 hours)**

Instructors to consult T9 for this subject

#### **2.2.1.13 Control System Fault Finding (3 hours)**

Instructors to consult T9 for this subject

### **2.2.2 Function test of electrical, electronic control equipment and safety devices**

#### **2.2.2.1 Function test of electrical, electronic control equipment and safety devices (12 hours)**

Instructors to consult T14, T23, T55 and T56 for this subject.

### **2.2.3 Troubleshooting of monitoring systems**

#### **2.2.3.1 Test and calibrations of sensors and transducers of monitoring system (12 hours)**

Instructors to consult T61 for this subject. Testing of sensors and calibration of instrumentation systems should be covered in extensive detail permitting demonstration and practical involvement.

The sensor testing should be realistic such as temperature baths for PT100's, thermocouples, thermistors and other heat sensing elements. The nature of the response is to be studied in accordance with the 'upstream requirements'.

*Note: This has a direct bearing on the understanding of Control systems (electronic type)*

Calibration is a function of procedure. The procedure for each instrumentation loop or system will be less or more extensive based on the hardware. The elements in the instrumentation loop need to be identified & then the element has to be calibrated.

E.g. Oxygen Monitor for IG systems – While the calibration procedure for a NGK or a Servomex would be explicitly mentioned in the manuals, it is actually a calibration of the functional electronics & the instrumentation amplifier. The primary sensor in this case cannot be accessed at all. The indicators in the loop for the CCR, bridge and other remote indications are however on a different loop

## **2.2.4 Software version control**

### **2.2.4.1 Programmable logic controllers (PLC)**

**(6 hours)**

Instructors should consult T52 for this subject

#### **Basics of PLC operation**

While covering the basics of PLC based systems operations a categorical division between what the PLC controls and what the rest of the hardware in a system independently manages shall be distinguished. Very often the PLC does not control various continuous control or analog parameters of the system & these are managed by discrete circuits or units.

#### **Comparison between hard-wired and programmable control operation**

The instructor must draw parallels & point out the differences & similarities between these two types of systems. Relay based systems allow for 'familiar' though not 'easy' troubleshooting. The concept of hardwiring to a PLC based system to peripheral devices & their control actions being governed by program or parametric changes needs to be covered in detail. This introduces the use & functions of registers, counters, timers and the necessary API's.

#### **Inputs and output modules and configuration of PLCs**

Various types of modules in a PLC based system are to be introduced. The analog modules are to be covered in reasonable detail covering the sections that lead to the various types of inputs & standard outputs that the system is capable of addressing/generating.



## Methods of Programming

Amongst the various methods of programming the 'Ladder logic' diagrams though increasingly popular, Human Machine Interface (HMI) and alteration of parameters in the programme is an important segment of this section. It is to be distinguished from upward network systems in the initial stages before the candidates are exposed to multi-drop systems with more than one 'Master' on the same system bus.

### 2.2.4.2 Microcontrollers

(6 hours)

Instructors should consult T62 for this subject.

While the working knowledge of microcontrollers varies from that of digital techniques or microprocessors applied to computational machines, the candidates must understand the implications of working with microcontrollers. The Motorola, Atmel, Philips and other derivatives of the 8051 or similar should be demonstrated with application areas, ranging from control system for supervision of machinery to embedded systems.

Communication related to microcontrollers shall be explained and the difference between the physical standard & the overlaying protocol aptly communicated. Due diligence must be paid so as not to generalize the communication interfaces between higher level platforms such as PLC and computers and the embedded system.

Noise immunity, crystal frequencies, buffer circuits, current drivers are within the gamut of this section.

### 2.2.4.3 Digital Techniques

(8 hours)

Instructors should consult T31, T51 and T52 for this subject.

**Logic Gates** – Instructors should demonstrate electronic gates and Boolean logic. Whilst this is done the need to co-relate 'gates' to analysis of pneumatic, hydraulic or electrical systems should be referenced. (E.g. valves in series, parallel etc.)

**Boolean Algebra** should be limited to equations and product of multiples should not be included nor Karnaugh maps.

The following gates should have been covered – NOT, AND, OR, NAND, EX-OR. The logical expression of the gate in terms of I/O relation should be covered. (E.g.  $Y = A.B$  [  $Y = A \text{ AND } B$  ])

The use of **counters** should be demonstrated through the use of a pulse generator and with a binary or decimal output. Co-relation between the counter and the pulse counter for rpm of the flywheel is a good starting point

**Flip – Flops** with clock (JK) shall be included for demonstration. Due reference to standby pump monitoring systems may be made and the conceptual building block be demonstrated by means of a bi-stable pneumatic directional control valve.

**Memories** – While the various types of memories covered in this section are relevant, trainees should be exposed to the awareness and develop an ability to recognize volatile & non-volatile memory elements. Genuine usage of this would reflect in the PLC or Industrial automation segment where the configuration settings are volatile. The use of a CMOS battery or backup battery should be duly covered in this section for the sake of completeness.

**Microprocessors** – The scope of the course should be taken into account & the depth of the subject should be limited to functional descriptions, working principles & interface to the real world. Similar techniques should be applied for **Microcontrollers**.

**ADC & DAC** – The principles of ADC (analog to digital conversion) having been covered the methods & circuit diagrams are unnecessary. The application of the ADC, the difference between analog instrumentation and ADC and multiplexers should be covered as a whole to orient the candidature towards automation and monitoring systems.

- **I/O** – While real world interfacing is covered, the intelligent CPU's covered in the microprocessors or microcontrollers section should be used to connect to hardware peripheral analog and digital loads such as lamps, switches, solenoids, meters, potentiometers. Due diligence must be paid to ensure that the candidate has an understanding of power sourced and the enhancement of power levels through galvanic isolation (relays, solid state power devices etc.)

Electronic troubleshooting shall include storing or referencing the volatile configuration settings of universal devices that may be used in various applications but are made specific for task by setting the configuration settings.

Chief Engineer Officer and Second Engineer Officer

Function 3:

**Maintenance and Repair at the Management Level**

## PART B3: COURSE OUTLINE

Knowledge, understanding and proficiency		Total hours for each topic	Total hours for each subject area of Required performance
<b>Competence:</b>			
<b>3.1</b>	<b>MANAGE SAFE AND EFFECTIVE MAINTENANCE AND REPAIR PROCEDURES</b>		
<b>3.1.1</b>	<b>MARINE ENGINEERING PRACTICE THEORETICAL KNOWLEDGE</b>		
	.1 Classification society and class certificates (Refer to 4.2.1.7)	-	
	.2 Statutory certification of ships (Refer to 4.2.1.7)	-	
	.3 Surveys for maintenance and renewal of class and statutory certificates (Refer to 4.2.1.7)	-	
	.4 Planned maintenance system as per ISM code.	5	
<b>3.1.2</b>	<b>MANAGE SAFE AND EFFECTIVE MAINTENANCE AND REPAIR PROCEDURES PRACTICAL KNOWLEDGE</b>		
	.1 Manage safe and effective maintenance and repair procedures relevant to 3.1.1	10	
<b>3.1.3</b>	<b>PLANNING MAINTENANCE, INCLUDING STATUTORY AND CLASS VERIFICATIONS PRACTICAL KNOWLEDGE</b>		
	.1 Planning maintenance, including statutory and class verifications relevant to 3.1.1	5	
<b>3.1.4</b>	<b>PLANNING REPAIRS PRACTICAL KNOWLEDGE</b>		
	.1 Planning repairs relevant to 3.1.1	5	25
<b>3.2</b>	<b>DETECT AND IDENTIFY THE CAUSE OF MACHINERY MALFUNCTIONS AND CORRECT FAULTS PRACTICAL KNOWLEDGE</b>		
<b>3.2.1</b>	<b>DETECTION OF MACHINERY MALFUNCTIONS, LOCATION OF FAULTS AND ACTION TO PREVENT DAMAGE</b>		
	.1 Unplanned maintenance	5	

<b>3.2.2</b>	<b>INSPECTION AND ADJUSTMENT OF EQUIPMENT</b>		
	.1 Inspection and adjustment of equipment relevant to 3.1.1	5	
<b>3.2.3</b>	<b>NON-DESTRUCTIVE EXAMINATION</b>		
	.1 Different types of non-destructive examination	10	20
<b>3.3</b>	<b>ENSURE SAFE WORKING PRACTICES <i>PRACTICAL KNOWLEDGE</i></b>		
<b>3.3.1</b>	<b>SAFE WORKING PRACTICES</b>		
	.1 Risk assessment	1	
	.2 Safety officials	1	
	.3 Personal protective equipments	1	
	.4 Work equipment	1	
	.5 Safety induction	1	
	.6 Fire precautions	1	
	.7 Emergency procedures	1	
	.8 Safe movement	1	
	.9 Safe system of works	1	
	.10 Entering enclosed or confined spaces	2	
	.11 Permit to work systems	2	
	.12 Manual handling	1	
	.13 Use of work equipment	1	
	.14 Lifting plants	1	
	.15 Maintenance of machineries	1	
	.16 Hot work	1	
	.17 Painting	1	
	.18 Hazardous substances	1	
	.19 Noise and vibrations	1	21
	<b>Total for Function 3: Maintenance and Repair at the Management Level</b>		<b>66</b>

## **PART C3: DETAILED TEACHING SYLLABUS**

### **COMPETENCE 3.1    MANAGE SAFE AND EFFECTIVE MAINTENANCE AND REPAIR PROCEDURES EQUIPMENT**

#### **TRAINING OUTCOMES:**

Demonstrates a knowledge and understanding of:

#### **3.1    MANAGE SAFE AND EFFECTIVE MAINTENANCE AND REPAIR PROCEDURES**

**3.1.1    MARINE ENGINEERING PRACTICE *THEORETICAL KNOWLEDGE***

**3.1.2    MANAGE SAFE AND EFFECTIVE MAINTENANCE AND REPAIR PROCEDURES *PRACTICAL KNOWLEDGE***

**3.1.3    PLANNING MAINTENANCE, INCLUDING STATUTORY AND CLASS VERIFICATIONS *PRACTICAL KNOWLEDGE***

**3.1.4    PLANNING REPAIRS *PRACTICAL KNOWLEDGE***

## **COMPETENCE 3.1    MANAGE SAFE AND EFFICIENT MAINTENANCE AND REPAIR PROCEDURES**

### **3.1.1    MARINE ENGINEERING PRACTICE *THEORETICAL KNOWLEDGE***

Required Performance:

- .1    Classification society and class certificates  
(Refer to 4.2.1.7)**
- .2    Statutory certification of ships  
(Refer to 4.2.1.7)**
- .3    Surveys for maintenance and renewal of class and statutory certificates  
(Refer to 4.2.1.7)**
- .4    Planned maintenance system (PMS) as per ISM code.    (5 hours)**
  - Objective of PMS
  - Equipment covered under PMS
  - Critical equipment
  - Preparation of vessel specific PMS
  - Maintenance schedule and job procedures
  - Updating of maintenance schedule
  - Spare parts inventory
  - Recording of defects

### **3.1.2    MANAGE SAFE AND EFFECTIVE MAINTENANCE AND REPAIR PROCEDURE PRACTICAL KNOWLEDGE**

Required Performance:

- .1    Manage safe and effective maintenance and repair procedures relevant  
to 3.1.1    (10 hours)**
  - Planned maintenance
    - Planned maintenance schedules
    - Spare parts inventory and determine availability of specific parts
    - Availability of specific tools and lifting equipment
    - Maintenance and repair procedures as per manufacturer's instruction manual.
  - Dry docking, In-water survey and lay up
    - Drydock repair file
    - Preparation of drydock repair specification
    - Drydocking and in-water survey
    - Initial and final drydock inspection.
    - Supporting the vessel in drydock.

- Preparations for drydocking and undocking.
- Survey work and maintenance during drydock.
- Typical arrangements for the supply of electrical power, fresh water and sanitation facilities while the vessel is in drydock.
- Special arrangements during drydock for the prevention of fires and explosions.
- The management of oil and water tanks during drydock. Testing of tanks by hydrostatic and pneumatic means.
- Describe the preparations, inspections, records, planning, maintenance and events which occur with dry docking and in-water hull surveys.
- Lay ups. Plan aspects of dry docking, in water hull cleaning, and vessel layup/reactivation.

### **3.1.3 MANAGE SAFE AND EFFECTIVE MAINTENANCE AND REPAIR PROCEDURE PRACTICAL KNOWLEDGE**

Required Performance:

#### **.1 Planning maintenance, including statutory and class verifications relevant to 3.1.1 (5 hours)**

- Planned maintenance – dismantling and inspection/calibrations
  - Dismantled in sequential order as per manufacturer's instruction manual
  - Cleaned prior to inspection
  - Inspected and/or calibrated as appropriate
  - Items are assessed to determine whether can be reused or need to be replaced/repaired/reconditioned
  - Above information recorded in maintenance record of equipment/machines
  - Entry completed in spare parts inventory
- Statutory and Class Verification Maintenance (Refer to 4.2.1.7)

### **3.1.4 PLANNING REPAIRS PRACTICAL KNOWLEDGE**

Required Performance:

#### **.1 Planning repairs relevant to 3.1.1 (5 hours)**

- Planned maintenance – assembly and testing
  - Individual parts are tested as per manufacturer's instruction manual
  - Parts are assembled in sequential order as per manufacturer's instruction manual
  - Pre-start checks are carried out in accordance with manufacturer's instruction manual



- Equipment/machinery is run up and relevant performance criteria are compared and recorded
- Updating of maintenance schedule records

**COMPETENCE 3.2 DETECT AND IDENTIFY THE CAUSE OF MACHINERY MALFUNCTIONS AND CORRECT FAULTS**

**TRAINING OUTCOME:**

Demonstrates a knowledge and understanding of:

**3.2.1 DETECTION OF MACHINERY MALFUNCTIONS, LOCATION OF FAULTS AND ACTION TO PREVENT DAMAGE**

**3.2.2 INSPECTION AND ADJUSTMENT OF EQUIPMENT**

**3.2.3 NON-DESTRUCTIVE EXAMINATION**



- Use of premixed aerosol cans of wet fluorescent iron oxide visible in ultraviolet rays
- Used for crack detection of tail end shaft taper
- Radiography
  - Use of radiography in testing welds
- Portable Hardness
  - Measurement of hardness by portable instrument
  - Used on board to check harness of turbocharger compressor impeller
- Thermography
  - Use of thermographic camera using infrared imaging
  - Used on board for measurement of temperature variations

### **COMPETENCE 3.3    Ensure safe working practices**

TRAINING OUTCOME:

Demonstrates a knowledge and understanding of:

#### **3.3.1    SAFE WORKING PRACTICES**

### **COMPETENCE 3.3    Ensure safe working practices**

#### **3.3.1    SAFE WORKING PRACTICES**

Required Performance:

- |   |                 |
|---|-----------------|
| <b>.1    Risk assessment</b>  | <b>(1 hour)</b> |
| <ul style="list-style-type: none"><li>○ Elements of risk assessment</li><li>○ Identify hazards</li><li>○ Identify risk controls</li><li>○ Estimate risks</li><li>○ Determine tolerability of risks</li><li>○ Prepare risk control action plan</li></ul> |                 |
| <b>.2    Safety officials</b>   | <b>(1 hour)</b> |
| <ul style="list-style-type: none"><li>○ Safety officer</li><li>○ Safety committee</li><li>○ Safety inspections</li><li>○ Investigation of accidents and dangerous occurrences</li></ul>   |                 |
| <b>.3    Personal protective equipments</b>   | <b>(1 hour)</b> |
| <ul style="list-style-type: none"><li>○ Types of personal protective equipments</li></ul>   |                 |
| <b>.4    Work equipment</b>   | <b>(1 hour)</b> |
| <ul style="list-style-type: none"><li>○ Maintenance</li><li>○ Inspection</li><li>○ Training</li><li>○ Electrical equipment</li></ul>  |                 |
| <b>.5    Safety induction</b>   | <b>(1 hour)</b> |
| <ul style="list-style-type: none"><li>○ Emergency procedures and fire precautions</li><li>○ Accidents and medical emergencies</li><li>○ Health and hygiene</li><li>○ Good housekeeping</li></ul>  |                 |

- Environmental responsibilities
- Occupational health and safety

**.6 Fire precautions (1 hour)**

- Smoking
- Electrical fittings
- Spontaneous combustion
- Precautions in machinery spaces

**.7 Emergency procedures (1 hour)**

- Action in the event of fire
- Muster and drills

**.8 Safe movement (1 hour)**

- Lighting
- Guarding of openings
- Watertight doors

**.9 Safe system of works (1 hour)**

- Working aloft
- Portable ladders
- Lagging of steam and exhaust pipes
- Unmanned machinery spaces
- Refrigeration machinery

**.10 Entering enclosed or confined spaces (2 hours)**

- Identifying hazards
  - Oxygen deficiencies
  - Toxicity of oil and other substances
  - Flammability
  - Other hazards
- Breathing apparatus and resuscitation equipment
- Preparing the space for entry
- Testing atmosphere of the space
- Procedures and arrangements before entry
- Procedures and arrangements during entry
- Procedures on completion

**.11 Permit to work systems (2 hours)**

- Work in unmanned machinery spaces
- Entry into enclosed or confined spaces

- Hot work
- Working aloft
- Electrical system for other than electrical officer

**.12 Manual handling (1 hour)**

- Musculo-skeletal injuries due to an unsatisfactory working method
- Appropriate steps to reduce risk of injury

**.13 Use of work equipment (1 hour)**

- Use of tools and equipment
- Abrasive wheels
- High pressure hydraulic and pneumatic equipments
- Ropes

**.14 Lifting plants (1 hour)**

- Safe working load (SWL)
- Register of lifting appliances, markings and certificates
- Regular maintenance
- Examination, inspection and testing
- Safety measures

**.15 Maintenance of machineries (1 hour)**

- Precautions before maintenance
- Warning notices not to start machines
- Securing heavy parts during maintenance

**.16 Hot work (1 hour)**

- Pre-use equipment test
- Precautions against fire and explosion
- Precautions during use of electric arc welding
- Compressed gas cylinders
- Gas welding and cutting

**.17 Painting (1 hour)**

- Preparation and precautions

**.18 Hazardous substances (1 hour)**

- Carcinogens and mutagens
- Asbestos dust
- Use of chemical agents

**.19 Noise and vibrations**

**(1 hour)**

- Assessing exposure to noise
- Types of vibration and their effects
- Prevention and control of exposure to noise and vibrations

## **PART D3: INSTRUCTOR MANUAL**

The following notes are intended to highlight the main objectives or training outcomes of each part of the function. The notes also contain some material on topics which are not adequately covered in the quoted references.

### **Function 3: Maintenance and Repair at the Management Level**

#### **3.1 MANAGE SAFE AND EFFECTIVE MAINTENANCE AND REPAIR PROCEDURES**

##### **3.1.1 MARINE ENGINEERING PRACTICE *THEORETICAL KNOWLEDGE* – 5 hours**

**3.1.1.1 Classification society and class certificates** (This is covered under competence 4.2.1.7)

**3.1.1.2 Statutory certification of ships** (This is covered under competence 4.2.1.7)

**3.1.1.3 Surveys for maintenance and renewal of class and statutory certificates** (This has covered under competence 4.2.1.7)

##### **3.1.1.4 Planned maintenance system (PMS) as per ISM Code (5 hours)**

The ship's safety management system (R4) as required by SOLAS (R1) Chapter VIII, should be consulted when planning maintenance and repair work. Refer also to V25 and V40.

Objective of PMS are

- Equipment covered under PMS
- Critical equipment
- Preparation of vessel specific PMS
- Maintenance schedule and job procedures
- Updating of maintenance schedule
- Spare parts inventory
- Recording of defects

Every Vessel must have a Vessel Specific Planned Maintenance System – PMS. The primary objective of the PMS is to improve the effectiveness of maintenance and ensure that machinery and equipment function in a safe, reliable and efficient manner.

The PMS, preferably computerized, should comprise of:

- Maintenance Schedules
- Spare Part Inventory
- Records of defects and breakdowns of the machinery and equipment.

The Chief Engineer and Chief Officer in consultation with the Superintendent are responsible for preparing the Vessel Specific PMS.



The PMS must cover the equipment as listed below:

- Critical Equipment
- Hull, Deck Machinery and Equipment
- Cargo Machinery, Equipment and Automation
- Life-saving and Fire-fighting equipment
- Navigational and Radio Equipment
- Main Engine, Auxiliary Engines, Auxiliary and Ancillary Machinery
- Electrical Machinery and Equipment
- Automation Equipment including Alarm and Cut-outs
- Calibration Equipment and Instruments
- Equipment supplied by charterer, owner or others, such as cargo handling equipment

Additionally the PMS can also be utilized to monitor Statutory and Class Surveys.

### **MAINTENANCE SCHEDULE – INTERVALS**

The following factors should be considered:

- Equipment Manufacturers Recommendations and Specifications.
- Company, Industry, Flag Administration standards and guidelines.
- Condition Monitoring and Predictive Maintenance techniques - i.e. vibration analysis.
- Practical experience and Historical trends in the results of routine inspections, and in the nature and rates of failures.
- The usage of the equipment – Continuous, Intermittent, Stand-by or Emergency.
- Practical or Operational restrictions, e.g. maintenance that can be performed only in dry-dock

### **MAINTENANCE SCHEDULE – TASK**

The Job procedure of each Maintenance Schedule Task must be included in Planned Maintenance System and should be in accordance with the Maker's Specific Instructions, Drawings and Service Notes. The Job Procedure should preferably include reference to the Instruction Manual i.e. Page or Drawing number.

### **ISSUING PMS MAINTENANCE SCHEDULES**

**Chief Engineer** and **Chief Officer** must ensure that the Maintenance schedules are extracted from the PMS every week. The jobs schedules should be given to the Person in charge of the maintenance. A record is to be maintained on board.

Depending on the Trade of the Vessels and nature of the Voyage forward planning must be carried out, Maintenance schedules should be preponed rather than postponed or allowed to become overdue.

If for any reason the Maintenance cannot be carried out, then the job should be postponed and reason for same should be recorded.

## **RESPONSIBILITIES FOR PERFORMING VARIOUS TASKS**

The job responsibilities for all personnel are listed in the Main Shipboard Manual, with detailed inspection responsibilities and Maintenance schedules included in various sections of the MTM. In event of absence of any personnel, the Master or the Chief Engineer may reassign the duties as deemed necessary, after making due consideration for competence and rest hours.

## **UPDATING COMPUTER BASED PMS MAINTENANCE SCHEDULE**

Officer in charge of the maintenance must ensure that the schedule is updated upon completion. The actual work carried out, condition of the equipment in particular critical parts and parts renewed must be entered in the PMS rather than just entering "Done" while updating the schedule. Where relevant, the exact values / readings / measurements observed at the time of overhaul / inspection must be stated in the records. Remarks are to be made if any part would need particular attention or renewal during the next overhaul. Unscheduled Inspections, Routine and Breakdown maintenance must be recorded in the PMS.

## **SPARE PARTS INVENTORY**

An up-to-date Spares Part Inventory is extremely important as it prevents short falls and overstocking. Shortfalls lead to last minute orders resulting in expensive airfreight, postponed maintenance, possible non-compliance in third party inspections and occasionally an incident. Over stocking is blocking money unnecessarily and could lead to loss to the Owners. If the vessel is sold these will be generously donated, for no appreciable value, to the next owner. The Inventory must be maintained within the PMS.

The Chief Engineer and Chief Officer in consultation with the Superintendent must prepare a Vessel specific List of Minimum spares to be maintained for Critical Equipment and Other Machinery/Equipment. The list of Minimum Spares should be prepared on the basis of a) Trading area of the Vessel, b) Duration of Voyages c) Availability of Spares from Manufacturers and d) Age of vessels.

The minimum spare parts list should be reviewed if the trading pattern of the vessel changes to areas where supplies are difficult to connect.

## **DEFECTS**

All Defects/Observations as observed on board must be recorded in the appropriate section of the PMS. The complete list of all such defects should be maintained by Chief Engineer and Chief Officer for their respective departments.

The Master and the Chief Engineer, within one month of joining, must send the update on the defect list to the vessel's Superintendent, making additions, if any.

The defects requiring shore assistance should be followed up separately on the Repair Order Forms. In case permanent repairs cannot be undertaken whilst the vessel is in service, then a Dry Dock Job Specification/Order should be raised. Computerized PMS that have the Defect Reporting feature may have a provision for raising Dry Dock Specifications.

## **CRITICAL EQUIPMENT**

Critical Equipment is defined as Machinery and Equipment on a Vessel including Alarms and Trips, the sudden failure of which may result in a hazardous situation thereby placing the personnel and/or vessel at risk.

Equipment with redundancy does not fall into the Critical Equipment category. E.g. Fire and GS Pumps.

Critical equipment must be clearly identified in the PMS.

## **RESPONSIBILITY**

No critical systems, alarms, control or shut down may be by-passed, inhibited or taken out of service without the permission of the Master. The Chief Engineer must approve any changes to critical alarms, control or shut down set points. The Chief Engineer is responsible for communicating any temporary deactivation of a critical alarm or system to the duty personnel. Only those personnel designated by the Chief Engineer are to work on any such critical systems.

## **INOPERATIVE - CRITICAL EQUIPMENT**

Any Critical Equipment found inoperative /defective must be reported immediately by a Non Routine Message to the Office and a Telephone call to the Technical Superintendent. An onboard Risk Assessment will have to be carried out, controls to mitigate any risk posed as a result of the defect will have to be established and put in place. If the Vessel is in Port, attempts should be made to have the Equipment repaired prior departure.

## **CRITICAL EQUIPMENT - MAINTENANCE**

If routine maintenance is required to be carried out on Critical Equipment, the Staff must carry out a Risk Assessment and forward the assessment to the Office. Only on approval from the Office can the Equipment be taken "Out of Service". If approval is received on phone, a confirmatory e-mail must be sent. 'Out of service' with respect to critical equipment may be defined as equipment that may be 'immobilized' either to carry out 'routine maintenance' or 'breakdown maintenance'. In either case a thorough risk assessment shall be carried out on board by the senior management identifying all hazards and with a backup plan to mitigate any eventuality. The senior management on board after quantifying the level of risk, whether low, medium or high, will inform office accordingly. Permission to carry out high risk maintenance activities on critical machinery shall be given by appropriate levels of management.

### **3.1.2 MANAGE SAFE AND EFFECTIVE MAINTENANCE AND REPAIR PROCEDURES *PRACTICAL KNOWLEDGE***

#### **3.1.2.1 Manage safe and effective maintenance and repair procedures relevant to 3.1.1 (10 hours)**

Ship's safety management system, as required by SOLAS (R1) Chapter VIII, should be consulted when carrying out maintenance and repair work. Manufacturer's Instruction and Operation Manual give guidance on maintenance. Spare parts availability should be checked before starting maintenance procedures. Availability of specific tools and lifting equipment safe should be determined.

Instructors should consult T36 for dry docking.

### **3.1.3 PLANNING MAINTENANCE, INCLUDING STATUTORY AND CLASS VERIFICATIONS *PRACTICAL KNOWLEDGE***

#### **3.1.3.1 Planning maintenance, including statutory and class verifications relevant to 3.1.1 (5 hours)**

For Machinery Surveys, Classification Societies offers four arrangements for Class follow-up of the components in the Machinery list. The best suited survey arrangement for the Manager depends on the company's maintenance strategy and operation.

The components covered by the four survey arrangements are listed in the Classification Society's machinery list. The components are given specific codes for easy identification.

#### **1. Survey arrangement Machinery Renewal**

Machinery Renewal is Classification Society's default survey arrangement. This survey arrangement is suitable for vessels which carry out most of the maintenance in dock.

#### **Rules and Requirements:**

All machinery is to be opened up and/ or function tested at each Main Class Renewal Survey (5 yearly). The time window for crediting: -/+ 15/0 months, no flexibility.

#### **Preparations for survey:**

As all Machinery Components are to be opened up and/ or tested at the end of the Renewal Class period, the crew and the Chief Engineer must be prepared for an extensive machinery inspection during Renewal survey. An important point is that even though a component has not achieved the maker's recommended running hours for overhaul, it must be opened up or tested during survey.

## **2. Survey Arrangement Machinery Continuous**

When operating with survey arrangement Machinery Continuous, the Manager is given more flexibility. Components are credited by Classification Society on a continuous basis, either during the annual surveys or when requested by the Manager.

### **Class involvement**

A Classification Society's Surveyor shall be called in every time a main overhaul is carried out for crediting of Class machinery. Half of all identical components of which there are more than one (e.g. fuel oil booster pumps for the main engine) in the Machinery list, can be credited by the Chief Engineer on behalf of Classification Society every second time overhaul is carried out. Postponement of components may be granted given that a sighting survey is carried out, and with a maximum period of 3 months.

### **Surveys/ Preparations**

No specific survey interval is required, but all components have to be surveyed with a maximum interval of 5 years. In the Classification Society's quarterly listing, the Machinery List will for each component show both the last survey date and the due date for the next survey.

## **3. Survey Arrangement Machinery PMS (Planned Maintenance System)**

Crediting of Machinery Components when on Machinery PMS is based on annual surveys and audits of the reported maintenance history in the vessel's computer based planned maintenance system.

All components in the Machinery List can be surveyed by the chief engineer at the time of overhaul. The component may then be credited by the discretion of the attending surveyor during the next annual survey based on the reported maintenance history for the component.

### **Conditions/ Requirements for PMS**

The approval of the survey arrangement Machinery PMS is directly connected to the technical management of the vessel. The Manager is given more flexibility and responsibility, and Classification Society performs audits of the planned maintenance programme rather than performing the actual component survey. In order to ensure that Class related Machinery components are given adequate follow up, the approval of the system itself and the on board system is connected to the Management of the vessel.

Machinery PMS will be deleted upon change of management or change of system. Please note that upon deletion of Machinery PMS, components with more than 5 years since last overhaul will be given a due date 6 months from the date that

Machinery PMS was deleted. The vessel will then be assigned to survey arrangement Machinery Continuous unless otherwise requested.

If a vessel changes Management, and the new Management wants to re-install Machinery PMS, a new initial survey is required to be carried out. Unless the new Manager has a system approval for the on board planned maintenance system, a system approval must be obtained before an initial survey can be carried out on board.

Prior to initial survey on board, the approval of the Manager to use the planned maintenance system must be in order.

### **Survey/Preparations: Machinery PMS Initial Survey**

An initial survey is required on board each vessel in order to obtain the survey arrangement Machinery PMS. The Chief Engineer's attendance is required throughout the entire duration of the survey, normally 5-8 hours. During the initial PMS Survey, the system will be audited with respect to the Classification Society's requirements. Main focus areas will be:

- Work/ job descriptions are to be in accordance with makers requirements and shall cover the Classification Society's requirements for class components.
- Classification Society's Machinery Component in the Machinery list included in the maintenance system on board with correct codes.
- All jobs for components with Class scope "main overhaul" shall be identified as Class jobs, with intervals according to maker's recommendations. No duplicate Class job in the system.
- Continuous improvement of the system. It is required to have a system for review of the planned maintenance system to further increase the focus on continuously improve the efficiency and the input quality of your system. All corrective jobs are to be identified and reviewed in an annual job. If many corrective jobs are identified on a specific component, the maintenance interval may be considered reduced. If intervals are to be increased beyond maker's recommended intervals, this shall be approved by the management's organisation ashore in agreement with maker, and may be accepted by the attending surveyor during the next annual survey.
- Circulating components. Components being re-used in several positions (cylinder covers, pistons, etc) must have a traceable maintenance history. This can either be part of the maintenance system, or kept as a separate system.
- If the vessel has class notation Unmanned Machinery Space (UMS), the UMS Class jobs have to be included and especially identified in the PMS.

If the requirements for Machinery PMS are not fulfilled, the survey arrangement will not be granted, or can be deleted if already in operation.

## **Survey/Preparations: Machinery PMS Annual Survey**

At the annual survey, the use of the system including the Chief Engineer's familiarity with it will be audited. In addition, the surveyor will review the machinery maintenance history in the PMS on board and perform a general inspection of the engine room.

The Chief Engineer has to prepare the print outs of the following reports before or during the survey:

- All main overhauls (Class linked jobs) carried out since last annual survey
- Overdue list.

If the requirements for the Machinery PMS are not fulfilled, a condition of class will be issued, and the survey arrangement may be deleted upon consideration.

## **Changing to Survey Arrangement Machinery PMS**

When planning a change to the survey arrangement Machinery PMS it is required that the software used for planned maintenance is approved by Classification Society. Additionally, the Manager needs to hold a company approval for the maintenance system itself and an approval for each applicable vessel. It is important to bear in mind that an installed Planned Maintenance System onboard, is not the same as having the survey arrangement Machinery PMS. Before changing to the Survey Arrangement Machinery PMS a successful initial survey must be carried out on each vessel. The maintenance system should have been in use for approximately 6 months before an initial survey is requested.

## **System requirements**

Several requirements apply to the maintenance system in use on board:

The planned maintenance system shall be computer based

- The system shall be able to produce a maintenance history report of all main overhauls carried out on class related machinery components during a specific period of time
- The system shall be able to identify all Class machinery with corresponding Classification Society's codes
- All corrective actions shall be especially identified in the system
- The job descriptions and maintenance history shall be in English
- A system for tracing circulating components should be in place (either included in the system or as a separate system)

## **Vessel Approval**

A vessel approval has to be granted to each vessel which the Manager wants to have on Survey Arrangement Machinery PMS. After completion of an initial survey, the survey report is evaluated by the Classification Society's Head Office. Upon the successful review, a certificate is issued and the vessel is transferred to survey arrangement Machinery PMS.

#### **4. Survey Arrangement Machinery CM (Condition Monitoring)**

Classification Society's has developed Machinery CM, intended for Managers with an implemented Condition Based Maintenance (CBM) strategy. Machinery CM allows the manager to adjust maintenance intervals based on the monitored condition of applicable components, which gives the manager optimised maintenance with significant flexibility. Machinery CM requires that Machinery PMS is already granted.

##### **Rules and Requirements:**

The operator must submit a CM programme for approval. The CBM must be a well established maintenance philosophy and strategy within the management before the process of Class approval can be initiated.

#### **3.1.4 PLANNING REPAIRS *PRACTICAL KNOWLEDGE***

##### **3.1.4.1 Planning repairs relevant to 3.1.1 (5 hours)**

Ship's safety management system, as required by SOLAS (R1) Chapter VIII, should be consulted when carrying out repair work. Manufacturer's Instruction and Operation Manual give guidance on repairs. Spare parts availability should be checked before starting repair procedures. Availability of specific tools and lifting equipment safe should be determined. Individual parts are to be tested as per manufacturer's instruction manual.

#### **3.2 DETECT AND IDENTIFY THE CAUSE OF MACHINERY MALFUNCTIONS AND CORRECT FAULTS *PRACTICAL KNOWLEDGE***

##### **3.2.1 DETECTION OF MACHINERY MALFUNCTIONS, LOCATION OF FAULTS AND ACTION TO PREVENT DAMAGE**

##### **3.2.1.1 Unplanned maintenance (5 hours)**

Comparison is made with normal operating values and abnormal operating conditions. Observation of physical parameters viz. vibrations, noise, temperature, pressures, levels, flow, etc. indicate abnormal conditions. Initial action taken when fault is first identified, considering vessel's safety. Bridge is notified of potential problems in good time. Senior engineers are advised when appropriate and advice sought in all cases of doubt. Priorities and scheduled work are re-assessed in light of identified fault. Errors are acknowledged, reported, recorded and corrective action taken.

##### **3.2.2 INSPECTION AND ADJUSTMENT OF EQUIPMENT**

##### **3.2.2.1 Inspection and adjustment of equipment relevant to 3.1.1 (5 hours)**

Inspection and adjustment of equipments to be carried out as per relevant data provided by the manufacturer's operating manual.



### **3.2.3 NON-DESTRUCTIVE EXAMINATION**

#### **3.2.3.1 Different types of non-destructive examination (10 hours)**

Instructors should consult T57 for (i) Visual Inspection (ii) Dye penetrant test (iii) Magnetic Particle Testing (iv) Radiography (v) Portable Hardness (vi) Thermography.

### **3.3 ENSURE SAFE WORKING PRACTICES PRACTICAL KNOWLEDGE**

#### **3.3.1 SAFE WORKING PRACTICES**

##### **3.3.1.1 Risk assessment (1 hour)**

Extensive guidance is available in T24. Refer also to V42 and V94.

##### **3.3.1.2 Safety officials (1 hour)**

Extensive guidance is available in T24.

##### **3.3.1.3 Personal protective equipments (1 hour)**

Extensive guidance is available in T24. Refer also to V49.

##### **3.3.1.4 Work equipment (1 hour)**

Extensive guidance is available in T24.

##### **3.3.1.5 Safety induction (1 hour)**

Extensive guidance is available in T24. Refer also to V29, V30, V31, V32, V33, V34, V35, V36 V38 and V39.

##### **3.3.1.6 Fire precautions (1 hour)**

Extensive guidance is available in T24. Refer also to V24 and V53.

##### **3.3.1.7 Emergency procedures (1 hour)**

Extensive guidance is available in T24.

##### **3.3.1.8 Safe movement (1 hour)**

Extensive guidance is available in T24.

##### **3.3.1.9 Safe system of works (1 hour)**

Extensive guidance is available in T24.

**3.3.1.10 Entering enclosed or confined spaces** (2 hour)

Extensive guidance is available in T24. Refer also to V55 V96 V98.

**3.3.1.11 Permit to work systems** (2 hour)

Extensive guidance is available in T24. Refer also to V49.

**3.3.1.12 Manual handling** (1 hour)

Extensive guidance is available in T24.

**3.3.1.13 Use of work equipment** (1 hour)

Extensive guidance is available in T24.

**3.3.1.14 Lifting plants** (1 hour)

Extensive guidance is available in T24.

**3.3.1.15 Maintenance of machineries** (1 hour)

Extensive guidance is available in T24.

**3.3.1.16 Hot work** (1 hour)

Extensive guidance is available in T24. Refer also to V95.

**3.3.1.17 Painting** (1 hour)

Extensive guidance is available in T24. Refer also to B35.

**3.3.1.18 Hazardous substances** (1 hour)

Extensive guidance is available in T24.

**3.3.1.19 Noise and vibrations** (1 hour)

Extensive guidance is available in T24. Refer to R50 for noise and T13 for vibrations. Also Guidance on vibrations is available on websites of Classifications Societies e.g. following:

[http://www.eagle.org/eagleExternalPortalWEB/ShowProperty/BEA%20Repository/Rules&Guides/Current/147\\_ShipVibration/Pub147\\_ShipVib](http://www.eagle.org/eagleExternalPortalWEB/ShowProperty/BEA%20Repository/Rules&Guides/Current/147_ShipVibration/Pub147_ShipVib)

Chief Engineer Officer and Second Engineer Officer

Function 4:

**Controlling the Operation of the Ship and Care for  
Persons on Board at the Management Level**

## PART B4: COURSE OUTLINE

Knowledge, understanding and proficiency		Total hours for each topic	Total hours for each subject area of Required performance
<b>Competence:</b>			
<b>4.1 CONTROL TRIM, STABILITY AND STRESS</b>			
<b>4.1.1</b>	<b>FUNDAMENTAL PRINCIPLES OF SHIP CONSTRUCTION AND THE THEORIES AND FACTORS AFFECTING TRIM AND STABILITY AND MEASURES NECESSARY TO PRESERVE TRIM AND STABILITY</b>		
	.1 Ship Types and Terms	4	
	.2 Stresses in Ship Structures	4	
	.3 Ship Construction	30	
	.4 Ship Dynamics	2	
	.5 Hydrostatics	3	
	.6 Displacement, TPC, Coefficients of Form	3	
	.7 Areas and Volumes of ship shapes, 1st and 2nd Moments	10	
	.8 Centres of Gravity	3	
	.9 Transverse Stability	7	
	.10 Trim	4	
	.11 Stability during drydocking and stability during grounding	2	
	.12 Resistance and Fuel Consumption	5	
	.13 Propeller and Power	5	
	.14 Rudders	3	85
<b>4.1.2</b>	<b>EFFECT ON TRIM AND STABILITY IN EVENT OF DAMAGE TO AND CONSEQUENT FLOODING OF COMPARTMENT AND COUNTERMEASURES TO BE TAKEN</b>		
	.1 Effect of flooding on transverse stability and trim	5	
	.2 Countermeasures to be taken	2	7
<b>4.1.3</b>	<b>IMO RECOMMENDATIONS CONCERNING SHIP STABILITY</b>		
	.1 IMO recommendations concerning ship stability	3	3

## 4.2 MONITOR AND CONTROL COMPLIANCE WITH LEGISLATIVE REQUIREMENTS AND MEASURES TO ENSURE SAFETY OF LIFE AT SEA AND PROTECTION OF THE MARINE ENVIRONMENT

<b>4.2.1</b>	<b>KNOWLEDGE OF RELEVANT INTERNATIONAL MARITIME LAW EMBODIED IN INTERNATIONAL AGREEMENTS AND CONVENTIONS</b>		
.1	United Nations Convention on the Law of Sea (UNCLOS)	3	
.2	Treaties, conventions, protocols, rules and regulations	2	
.3	International Maritime Organisation (IMO)	2	
.4	List of IMO Conventions	4	
.5	Introduction to International Labour Organisation (ILO)	1	
.6	World Health Organisation (WHO)	1	
.7	Authorities & Regulations	5	18
<b>4.2.2</b>	<b>CERTIFICATES AND OTHER DOCUMENTS TO BE CARRIED ON BOARD SHIPS BY INTERNATIONAL CONVENTIONS, HOW THEY MAY BE OBTAINED AND PERIOD OF THEIR LEGAL VALIDITY</b>		
.1	List of Certificates and documents to be carried on board ships as per SOLAS Annex 1, how they are obtained and their period of validity	2	
.2	Additional certificates and documents required on board ships	1	3
<b>4.2.3</b>	<b>RESPONSIBILITIES UNDER THE RELEVANT REQUIREMENTS OF THE INTERNATIONAL CONVENTION ON LOAD LINES</b>		
.1	International Convention on Load Lines	3	3
<b>4.2.4</b>	<b>RESPONSIBILITIES UNDER THE RELEVANT REQUIREMENTS OF THE INTERNATIONAL CONVENTION FOR THE SAFETY OF LIFE AT SEA</b>		
.1	Brief description of International Convention for the Safety of Life at Sea	2	
.2	Obligation to carry out surveys and maintain validity of certificates	1	
.3	Obligation to maintain records	1	
.4	Obligation and rights of master	1	5

<b>4.2.5</b>	<b>RESPONSIBILITIES UNDER THE RELEVANT REQUIREMENTS OF THE INTERNATIONAL CONVENTION FOR THE PREVENTION OF POLLUTION FROM SHIPS</b>		
	.1 Annex I	1	
	.2 Annex II	1	
	.3 Annex III	0.5	
	.4 Annex IV	0.5	
	.5 Annex V	1	
	.6 Annex VI	1	5
<b>4.2.6</b>	<b>MARITIME DECLARATIONS OF HEALTH AND THE REQUIREMENTS OF THE INTERNATIONAL HEALTH REGULATIONS</b>		
	.1 WHO's International Health Regulations 2005 (IHR)	3	
	.2 International Medical Guide for ships (IMGS)	1	
	.3 IMO's Medical First Aid Guide (MFAG)	0.5	
	.4 WHO's Guidelines for drinking water quality	0.5	5
<b>4.2.7</b>	<b>RESPONSIBILITIES UNDER INTERNATIONAL INSTRUMENTS AFFECTING THE SAFETY OF THE SHIPS, PASSENGERS, CREW OR CARGO</b>		
	.1 ILO's Maritime Labour Convention 2006 (MLC 2006)	4	
	.2 Convention on the International Regulation for Preventing Collisions at Sea (COLREG) 1972	1	
	.3 International Convention on Salvage 1989; Lloyd's Standard Form of Salvage Agreement (LOF 2000)	1	
	.4 Convention on Limitation of Liability of Maritime Claims 1976	1	
	.5 International Convention for the Unification of certain Rules of Law relating to Bills of Lading (Hague-Visby Rules)	1	
	.6 Charter parties	3	
	.7 Marine Insurance, General Average and P & I Club	4	15
<b>4.2.8</b>	<b>METHODS AND AIDS TO PREVENT POLLUTION OF THE ENVIRONMENT BY SHIPS</b>		
	.1 List of Conventions – Refer to 4.2.1.4	-	
	.2 Sources of Marine Pollution	1	
	.3 Effects of Marine oil spills	1	
	.4 Regulations for prevention of oil pollution as per Annex I of MARPOL 73/78	4	

.5	Regulations for control of pollution from Noxious liquid substances carried in bulk as per Annex II of MARPOL 73/78	1	
.6	Regulations for the Prevention of Pollution by Harmful substances carried by sea in packaged form as per Annex III of MARPOL 73/78	0.5	
.7	Requirements covering the carriage of dangerous goods by sea as per Chapter VII of the SOLAS Convention	0.5	
.8	Regulations for the Prevention of Pollution by Sewage from Ships as per Annex IV of MARPOL 73/78	2	
.9	Regulations for the Prevention of Pollution by Garbage from Ships as per Annex V of MARPOL 73/78	2	
.10	Regulations for the Prevention of Air Pollution as per Annex VI of MARPOL 73/78	3	
.11	International Convention for the Control and Management of Ship's Ballast Water and Sediments	2	
.12	International Convention for the Control of Harmful Anti-Fouling Systems on Ships (AFS) 2001	1	
.13	Noise	1	19

#### 4.2.9 NATIONAL LEGISLATION FOR IMPLEMENTING INTERNATIONAL AGREEMENTS AND CONVENTIONS

Refer to Guidelines

### 4.3 MAINTAIN SAFETY AND SECURITY OF THE VESSEL, CREW AND PASSENGERS AND THE OPERATIONAL CONDITION OF THE LIFE SAVING, FIRE FIGHTING AND OTHER SAFETY SYSTEMS.

#### 4.3.1 LIFE SAVING APPLIANCES REGULATIONS ( SOLAS )

.1	Life-Saving appliances and arrangements (Chapter III of SOLAS) And Life-Saving Appliance Code	2	2
----	---	---	---

#### 4.3.2 ORGANISATION OF FIRE AND ABANDON SHIP DRILL

.1	Organisation of Fire and Abandon Ship Drills	1	1
----	--	---	---

<b>4.3.3</b>	<b>MAINTENANCE OF LIFE-SAVING, FIRE-FIGHTING AND OTHER SAFETY SYSTEMS.</b>		
.1	Maintenance of Life-Saving, Fire-fighting and other safety system	3	3
<b>4.3.4</b>	<b>ACTIONS TO BE TAKEN TO PROTECT AND SAFEGUARD ALL PERSONS ON BOARD IN EMERGENCIES</b>		
.1	Actions to protect and safeguard all persons on board in emergencies; Rescue of persons from a vessel in distress or from a wreck; and Man-overboard procedures	1	1
<b>4.3.5</b>	<b>ACTION TO LIMIT DAMAGE AND SALVE THE SHIP FOLLOWING FIRE, EXPLOSION, COLLISION OR GROUNDING</b>		
.1	Contingency plans for response to emergencies	1	
.2	Means of limiting damage and salvaging the ship following a fire or explosion	1	
.3	Procedures for abandoning ship	1	3
<b>4.4</b>	<b>DEVELOP EMERGENCY AND DAMAGE CONTROL PLANS AND HANDLE EMERGENCY SITUATION</b>		
<b>4.4.1</b>	<b>SHIP CONSTRUCTION, INCLUDING DAMAGE CONTROL</b> (Refer to 4.1.1.3) & (Refer to 4.1.1.5)	-	-
<b>4.4.2</b>	<b>METHODS AND AIDS FOR FIRE PREVENTION, DETECTION AND EXTINCTION</b>		
.1	Fire -fighting equipment	3	3
<b>4.4.3</b>	<b>FUNCTIONS AND USE OF LIFE SAVING APPLIANCES</b>		
.1	Life saving appliances	2	2
<b>4.5</b>	<b>USE LEADERSHIP AND MANAGERIAL SKILLS</b>		
<b>4.5.1</b>	<b>KNOWLEDGE OF SHIPBOARD PERSONNEL MANAGEMENT AND TRAINING</b>		
.1	Engineer and Manager	1	
.2	Human Resource Management	1	
.3	Training and Development	2	
.4	Maintenance Management	2	6



<b>4.5.2</b>	<b>KNOWLEDGE OF INTERNATIONAL MARITIME CONVENTIONS AND RECOMMENDATIONS AND RELATED NATIONAL LEGISLATIONS</b>		
	.1 The ISM Code (Refer to 4.2.4.1)	-	
	.2 STCW Convention	1	
	.3 ILO's MLC 2006 (Refer to 4.2.7.1/2/3/4)	-	1
<b>4.5.3</b>	<b>ABILITY TO APPLY TASK AND WORKLOAD MANAGEMENT</b>		
	.1 Communication	1	
	.2 Team building	1	
	.3 Planning and co-ordination	1	
	.4 Personal assignments	1	
	.5 Time and resource constraints	1	
	.6 Prioritization	1	6
<b>4.5.4</b>	<b>KNOWLEDGE AND ABILITY TO APPLY EFFECTIVE RESOURCE MANAGEMENT</b>		
	.1 Allocation, assignment and prioritization of resources	1	
	.2 Effective communication on board and ashore	1	
	.3 Decisions reflect consideration of team experience	1	3
<b>4.5.5</b>	<b>KNOWLEDGE AND ABILITY TO APPLY DECISION-MAKING TECHNIQUES</b>		
	.1 Management processes and functions	2	
	.2 Negotiating skills	2	
	.3 Situation and risk assessment	1	
	.4 Identify and generate options	1	
	.5 Select course of action	1	
	.6 Evaluation of outcome effectiveness	1	8
<b>4.5.6</b>	<b>DEVELOPMENT, IMPLEMENTATION, AND OVERSIGHT OF STANDARD OPERATING PROCEDURES</b>		
	.1 Project planning and controlling	3	3
<b>Total for Function 4: Controlling the Operation of the Ship and Care for Persons on Board at the Management Level</b>			<b>210</b>

## **PART C4: DETAILED TEACHING SYLLABUS**

### **COMPETENCE 4.1 CONTROL TRIM, STABILITY AND STRESS**

#### **TRAINING OUTCOMES:**

Demonstrates a knowledge and understanding of:

#### **4.1 MANAGE SAFE AND EFFECTIVE MAINTENANCE AND REPAIR PROCEDURES**

**4.1.1 FUNDAMENTAL PRINCIPLES OF SHIP CONSTRUCTION AND THE THEORIES AND FACTORS AFFECTING TRIM AND STABILITY AND MEASURES NECESSARY TO PRESERVE TRIM AND STABILITY**

**4.1.2 EFFECT ON TRIM AND STABILITY IN EVENT OF DAMAGE TO AND CONSEQUENT FLOODING OF A COMPARTMENT AND COUNTERMEASURES TO BE TAKEN**

**4.1.3 IMO RECOMMENDATIONS CONCERNING SHIP STABILITY**

## **COMPETENCE 4.1 CONTROL TRIM, STABILITY AND STRESS**

### **4.1.1 FUNDAMENTAL PRINCIPLES OF SHIP CONSTRUCTION AND THE THEORIES AND FACTORS AFFECTING TRIM AND STABILITY AND MEASURES NECESSARY TO PRESERVE TRIM AND STABILITY**

Required Performance:

- .1 Ship Types and Terms (4 hours)**
- Ship types: passenger ships, cargo liners, oil tankers, bulk carriers, container ships, roll-on/roll-off vessels, liquefied gas carriers, chemical carriers.
  - Terms used in the measurement of ships: after perpendicular, forward perpendicular, length overall, length between perpendiculars, breadth extreme, breadth moulded, depth extreme, depth moulded, draught extreme, draught moulded, freeboard, camber, sheer, rise of floor, bilge radius, tumble home, flare, stem rake, keel rake, entrance, run, displacement, lightweight, deadweight.
  - Tonnage rules.
  - Load line rules.
- .2 Stresses in Ship Structures (4 hours)**
- Terms used to describe stresses in ship structures: longitudinal bending, still water bending, load diagram, shear force diagram, bending moment diagram, hogging, sagging, wave bending, transverse bending.
  - Docking, grounding.
  - Pounding, panting.
- .3 Ship Construction (30 hours)**
- Terms used to describe structural members: keel, bilge keel, duct keel, bottom plating, double bottom, tank top, girder, centre girder, side girder, floor, side frame, shell plating, deck plating, flanges, margin plate, longitudinal, intercostal, stiffener, web frame, bulkhead, collision bulkhead, panting stringer, stringer, pillars, garboard strake, sheer strake.
  - Double bottom construction.
  - Safety features for duct keels.
  - Forward and after peak structures.
  - Anchor cable termination details.
  - Longitudinal, transverse and combined framed vessels.
  - Decks
  - Hatch covers
  - Bulwarks
  - Deep frames.
  - Design consideration for discontinuities in the vessel structure.
  - Bilge keel consideration.

- Strakes for the hull.
- Fitting through the hull.
- Engine, deck machinery and stabiliser strength members.
- Bulkhead construction and their position.
- Maintenance of strength and watertight integrity when bulkheads are pierced for normal operation.
- Rudder and its support arrangements.
- Stern frame
- Design criteria for specialised ships.
- Structural fire protection.
- Ship's General arrangement drawing
- Shell expansion
- Deck plan
- Midship section

**.4 Ship Dynamics (2 hours)**

- Ship motions
  - Rolling – period of roll and isochronous rolling
  - Pitching
  - Heaving
- Bilge keels.
- Fin Stabilisers.
- Passive and active anti-roll tanks.
- Vibration.

**.5 Hydrostatics (3 hours)**

- Density.
- Relative density.
- Pressure exerted by a liquid.
- Load on an immersed plane.
- Centre of pressure.
- Load diagram.
- Shearing force on bulkhead stiffeners.

**.6 Displacement, TPC, Coefficients of Form (3 hours)**

- Archimedes' principle.
- Displacement.
- Tonne Per Centimetre immersion ( TPC)
- Block coefficient.
- Prismatic coefficient.
- Midship coefficient.
- Waterplane area coefficient.
- Wetted surface area.
- Similar figures.
- Influence of hull form on coefficients.

**.7 Areas and Volumes of Ship Shapes, First and Second Moments (10 hours)**

- Simpson's 1st and 2nd Rules for areas and volumes.
- Application of Simpson's rules to calculate areas and volumes.
- Common areas such as waterplanes, sections and bulkheads.
- Immersed volume of hull by sections and waterplanes.
- Simpson's 1st and 2nd Rules for 1st moments and centroids.
- Application of Simpson's Rules to find centroids.
- Centroids of common areas such as, waterplanes, sections and bulkheads.
- Vertical Centre of Buoyancy, VCB; Longitudinal Centre of Buoyancy, LCB.
- Simpson's 1st and 2nd Rules for 2nd moments of area.
- Application of Simpson's Rules to find 2nd moments of area.
- Transverse moment of inertia,  $I_T$ ; Longitudinal moment of inertia,  $I_L$ .

**.8 Centres of Gravity (3 hours)**

- Longitudinal centre of gravity
- Vertical centre of gravity
- Shift in centre of gravity due to the addition, removal or transfer of masses.
- Effect of a suspended mass.

**.9 Transverse Stability (7 hours)**

- Vertical centre of buoyancy
- Hydrostatic tables.
- Transverse metacentric height, GM.
- Righting lever, GZ.
- Stability at small angles of heel.
- Metacentric diagram.
- Inclining experiment.
- Free surface effect.
- Stability at large angles of heel.
- Cross curves of stability, KN Tables.
- Curve of statical stability.
- Dynamical stability.
- Angles of loll, list.

**.10 Trim (4 hours)**

- Centre of flotation
- Mean draught.
- Longitudinal metacentre.
- Change in draughts due to added masses.
- Moment to Change Trim 1 centimetre.
- Change in draughts due to a change in density.
- Change in trim due to change in density

**.11 Stability during Drydocking and stability during grounding (2 hours)**

- Stability when docking
- Stability on grounding

**.12 Resistance and Fuel Consumption (5 hours)**

- Frictional resistance.
- REYNOLDS' number.
- Residuary resistance.
- Froude number.
- Speed length ratio.
- Effective power.
- Admiralty coefficient.
- Fuel coefficient and fuel consumption.

**.13 Propellers and Power (5 hours)**

- Terms used in the calculation of propulsion coefficients: diameter, pitch, pitch ratio, theoretical speed, apparent slip, wake fraction, real slip, projected area, developed area, blade area ratio, disc area ratio.
- Terms used in the calculation of power factors: thrust power, shaft power, delivered power, thrust deduction factor, effective power, quasi-propulsive coefficient.
- Measurement of pitch.
- Cavitation.
- Ship trials – speed measurements

**.14 Rudders (2 hours)**

- Force on a rudder.
- Torque on a rudder stock.
- Angle of heel due to force on rudder.
- Angle of heel when turning.

**4.1.2 EFFECT ON TRIM AND STABILITY IN EVENT OF DAMAGE TO AND CONSEQUENT FLOODING OF A COMPARTMENT AND COUNTERMEASURES TO BE TAKEN**

Required Performance:

**.1 Effect of flooding on transverse stability and trim (5 hours)**

- Grounding, damage and bilging.
- Bilging amidships compartment
- Bilging of side compartment -
- Bilging end compartment
- Effect of bilging on stability (Draft, Trim, List and GM) – by lost buoyancy method and by added mass method

- .2 Countermeasures to be taken (2 hours)**
- Countermeasures – cross flooding of compartments – details in damage control plan

**4.1.3 IMO RECOMMENDATIONS CONCERNING SHIP STABILITY**

Required Performance:

- .1 IMO recommendations concerning ship stability (3 hours)**
- International Code of Intact Stability, 2008 (2008 IS code)
  - Damage control plan
  - Damage control booklet
  - Use of on-board computers
  - Shore based emergency response system

**COMPETENCE 4.2 MONITOR AND CONTROL COMPLIANCE WITH LEGISLATIVE REQUIREMENTS AND MEASURES TO ENSURE SAFETY OF LIFE AT SEA AND PROTECTION OF THE MARINE ENVIRONMENT**

**TRAINING OUTCOMES:**

Demonstrates a knowledge and understanding of:

**4.2 MONITOR AND CONTROL COMPLIANCE WITH LEGISLATIVE REQUIREMENTS AND MEASURES TO ENSURE SAFETY OF LIFE AT SEA AND PROTECTION OF THE MARINE ENVIRONMENT**

**4.2.1 RELEVANT INTERNATIONAL MARITIME LAW EMBODIED IN INTERNATIONAL AGREEMENT AND CONVENTIONS**

**4.2.2 CERTIFICATES AND OTHER DOCUMENTS REQUIRED TO BE CARRIED ON BOARD SHIPS BY INTERNATIONAL CONVENTIONS, HOW THEY MAY BE OBTAINED AND PERIOD OF THEIR LEGAL VALIDITY**

**4.2.3 RESPONSIBILITIES UNDER THE RELEVANT REQUIREMENTS OF THE INTERNATIONAL CONVENTION ON LOAD LINES**

**4.2.4 RESPONSIBILITIES UNDER THE RELEVANT REQUIREMENTS OF THE INTERNATIONAL CONVENTION FOR THE SAFETY OF LIFE AT SEA**

**4.2.5 RESPONSIBILITIES UNDER THE RELEVANT REQUIREMENTS OF THE INTERNATIONAL CONVENTION FOR THE PREVENTION OF POLLUTION FROM SHIPS**

**4.2.6 MARITIME DECLARATIONS OF HEALTH AND THE REQUIREMENTS OF THE INTERNATIONAL HEALTH REGULATIONS**

**4.2.7 RESPONSIBILITIES UNDER INTERNATIONAL INSTRUMENTS AFFECTING THE SAFETY OF THE SHIPS, PASSENGERS, CREW OR CARGO**

**4.2.8 METHODS AND AIDS TO PREVENT POLLUTION OF THE ENVIRONMENT BY SHIPS**

**4.2.9 NATIONAL LEGISLATION FOR IMPLEMENTING INTERNATIONAL AGREEMENTS AND CONVENTIONS**



**COMPETENCE 4.2 MONITOR AND CONTROL COMPLIANCE WITH LEGISLATIVE REQUIREMENTS AND MEASURES TO ENSURE SAFETY OF LIFE AT SEA AND PROTECTION OF THE MARINE ENVIRONMENT**

**4.2.1 KNOWLEDGE OF RELEVANT INTERNATIONAL MARITIME LAW EMBODIED IN INTERNATIONAL AGREEMENTS AND CONVENTIONS**

Required Performance:

**.1 United Nations Convention on the Law of Sea 1982 (UNCLOS) (3 hours)**

- Introduction
- Limits of territorial sea innocent passage in territorial sea
- Freedom of high seas
- Nationality of ships
- Duties of flag state
- Penal jurisdiction in matters of collision or any other incident of navigation
- Duty to render assistance
- Measures to prevent , reduce and control pollution of the marine environment
- Port state, coastal state and flag state jurisdiction
- Criminal jurisdiction on board a foreign ship
- Civil jurisdiction in relation to foreign ships

**.2 Treaties, conventions, protocols, rules and regulations (2 hours)**

- Treaties
- Conventions
- Protocols
- Adoption of convention
- Signature, ratification, acceptance and approval
- Accession
- Amendments and tacit acceptance
- Rules and regulations

**.3 International Maritime Organization (IMO) (2 hours)**

- IMCO convention 1948 - purpose of organisation, name changed to IMO in 1982
- Structure – Assembly, Council, Maritime Safety Committee (MSC), Marine Environment Protection Committee (MEPC), Legal Committee, Technical Co-operation Committee, Facilitation Committee, Sub-Committees and Secretariat
- IMO Codes and Recommendations on Cargoes; Marine technology; Marine environment; Navigation, Radio communications; and Training and certification

#### **.4 List of IMO Conventions**

**(4 hours)**

- Conventions related to Maritime Safety – brief introduction to following conventions
  - International Convention for the Safety of Life at Sea (SOLAS), 1974
  - International Convention on Load Lines (LL), 1966
  - Special Trade Passenger Ships Agreement (STP), 1971
  - Convention on the International Regulations for Preventing Collisions at Sea (COLREG), 1972
  - International Convention for Safe Containers (CSC), 1972
  - Convention on the International Maritime Satellite Organization (INMARSAT), 1976
  - The Torremolinos International Convention for the Safety of Fishing Vessels (SFV), 1977
  - International Convention on Standards of Training, Certification and Watchkeeping for Seafarers (STCW), 1978
  - International Convention on Standards of Training, Certification and Watchkeeping for Fishing Vessel Personnel (STCW-F), 1995
  - International Convention on Maritime Search and Rescue (SAR), 1979
- Conventions related to Marine Pollution– brief introduction to following conventions
  - International Convention for the Prevention of Pollution from Ships, 1973, as modified by the Protocol of 1978 relating thereto (MARPOL 73/78)
  - International Convention Relating to Intervention on the High Seas in Cases of Oil Pollution Casualties (INTERVENTION), 1969
  - Convention on the Prevention of Marine Pollution by Dumping of Wastes and Other Matter (LDC), 1972
  - International Convention on Oil Pollution Preparedness, Response and Co-operation (OPRC), 1990
  - Protocol on Preparedness, Response and Co-operation to pollution Incidents by Hazardous and Noxious Substances, 2000 (HNS Protocol)
  - International Convention on the Control of Harmful Anti-fouling Systems on Ships (AFS), 2001
  - International Convention for the Control and Management of Ships' Ballast Water and Sediments, 2004
  - Conventions related to Liability and Compensation– brief introduction to following conventions
    - International Convention on Civil Liability for Oil Pollution Damage (CLC), 1969 The Protocol of 1992 and The 2000 Amendments
    - International Convention on the Establishment of an International Fund for Compensation for Oil Pollution Damage (FUND), 1971 and The Protocol of 1992
    - Convention relating to Civil Liability in the Field of Maritime Carriage of Nuclear Material (NUCLEAR), 1971
    - Athens Convention relating to the Carriage of Passengers and their Luggage by Sea (PAL), 1974
    - Convention on Limitation of Liability for Maritime Claims (LLMC), 1976
    - International Convention on Liability and Compensation for Damage in Connection with the Carriage of Hazardous and Noxious Substances by Sea (HNS), 1996

- International Convention on Civil Liability for Bunker Oil Pollution Damage, 2001
- Conventions on other subjects – brief introduction to following conventions
  - Convention on Facilitation of International Maritime Traffic (FAL), 1965
  - International Convention on Tonnage Measurement of Ships (TONNAGE), 1969
  - Convention for the Suppression of Unlawful Acts Against the Safety of Maritime Navigation (SUA), 1988
  - Protocol for the Suppression of Unlawful Acts Against the Safety of Fixed Platforms Located on the Continental Shelf, 1988
  - International Convention on Salvage (SALVAGE), 1989

**.5 Introduction to International Labour Organisation (ILO) (1 hour)**

- Created to develop international labour standards and to ensure their application
- How ILO works – tripartite structure (governments, employers and workers)

**.6 World Health Organisation (WHO) (1 hour)**

- United Nations specialized agency for health

**.7 Authorities and Regulations (5 hours)**

- Flag state
  - Duties of flag state
  - Certificate of registration under UNCLOS
  - Member of IMO
  - Signing and ratifying conventions
  - Framing rules for ships under its flag to meet the requirements of conventions that it has ratified
  - Issuing certificate of competency and endorsements to officers and crew
  - Carryout investigations and inquiries
- Port State
  - Aim to eliminate Sub-standard ships in order to ensure safer ships and cleaner oceans
  - Following Conventions permit Port State Control
    - ❖ SOLAS 1974
    - ❖ LOADLINES 1966
    - ❖ MARPOL 73/78
    - ❖ STCW 1978
    - ❖ COLREG 1972
    - ❖ TONNAGE 69
    - ❖ MLC 2006
    - ❖ IHR 2005
  - Procedure for port state control

- Classification Society
  - Scope of classification
  - Assignment, maintenance, suspension and withdrawal of class
  - Classification surveys
  - Period of certificate of class, anniversary date, window period, overdue surveys, recommendation/condition of class and memoranda
  - Statutory certification of ships
  - Recognized organization
- IACS
  - Unified requirements
  - Unified interpretations
  - Procedural requirements

**4.2.2 CERTIFICATES AND OTHER DOCUMENTS TO BE CARRIED ON BOARD SHIPS BY INTERNATIONAL CONVENTIONS, HOW THEY MAY BE OBTAINED AND PERIOD OF THEIR LEGAL VALIDITY**

Required Performance:

- .1 List of Certificates and documents to be carried on board ships as per SOLAS Annex 1, how they are obtained and their period of validity (2 hours)**
- .2 Additional certificates and documents required on board ship (1 hour)**
  - Classification Society Certificates for Hull and Machinery
  - Anchor and Chain Cable Certificate
  - Inflatable Liferaft Inspection Certificates
  - Official Log-book; Deck, Engine-room and Radio Log-books
  - Articles of Agreement with the Crew
  - Seamen's Discharge Books
  - general declaration
  - cargo declaration
  - dangerous goods manifest or plan
  - ship's stores declaration
  - crew's effects declaration
  - crew list
  - passenger list
  - Ship Sanitation Control Exemption Certificate or Ship Sanitation Control Certificate
  - Maritime Declaration of Health
  -

#### 4.2.3 RESPONSIBILITIES UNDER THE RELEVANT REQUIREMENTS OF THE INTERNATIONAL CONVENTION ON LOAD LINES

Required Performance:

##### **.1 International Convention on Load Lines (3 hours)**

- Salient features
- Record of conditions of assignment of Load Line
- Requirements for initial and periodical surveys
- Requirements for periodical inspections and endorsements on the ILL Certificate
- Fittings and appliances that are inspected
- Stability book gives loading and ballasting of the ship and its stability under varying conditions of service

#### 4.2.4 RESPONSIBILITIES UNDER THE RELEVANT REQUIREMENTS OF THE INTERNATIONAL CONVENTION FOR THE SAFETY OF LIFE AT SEA

Required Performance:

##### **.1 International Convention for the Safety of Life at Sea – Brief description of following chapters: (2 hours)**

- Chapter I – General provisions
- Chapter II-1 – Construction – Structure, subdivision and stability, machinery and electrical installations
- Chapter II-2 – Construction – Fire protection, fire detection and fire extinction
- Chapter III – Life saving appliances and arrangements
- Chapter IV – Radio communications
- Chapter V – Safety of Navigations
- Chapter VI – Carriage of cargoes
- Chapter VII – Carriage of dangerous goods
- Chapter VIII – Nuclear Ships
- Chapter IX – Management for the safe operations of ships
- International Safety Management (ISM) Code)
  - Aims and objectives.
  - Advantages and disadvantages of ISM and SMS (Safety Management System).
  - SMS code clauses.
  - SMS development. ISM and SMS documentation. I
  - SMS certification and audit.
- Chapter X – Safety measures for high speed craft
- Chapter XI-1 – Special measures to enhance maritime safety
- Chapter XI-2 - Special measures to enhance maritime security

- The International Ship and Port Facility Security Code (ISPS Code)
    - Aims and Objectives
    - Compliance of the code
    - Implementation of the code
    - Role of Ship's security officer
    - Levels of security
    - Addressing major security concerns and potential threats
  - Chapter XII – Additional safety measures for bulk carriers
- .2 Obligation to carry out periodical surveys and maintain validity of following certificates: (1 hour)**
- Safety Management Certificate
  - International Ship Security Certificate
  - For passenger ships – Passenger ship safety certificate
  - For cargo ships – Cargo ship safety construction certificate, cargo ship safety equipment certificate, cargo ship safety radio certificate
  - For specialized vessels – their appropriate certificates
- .3 Obligation to maintain following records: (1 hour)**
- On board training and drills record
  - Voyage data recorder system annual performance test
  - Ship Security Plan records
  - Continuous Synopsis records
- .4 Obligation and rights of master (1 hour)**
- Obligation to send danger messages relating to ice, danger to navigation, storms
  - Obligation of master to provide assistance on receiving a distress signal
  - Rights of a master of a ship in distress to requisition assistance
  - Obligation to navigate safely
  - Obligation to sufficiently and efficiently man the ship
  - Obligation to permit ship to Port State Control inspection
  - Obligation to carry out testing of steering gear and emergency steering drill and entry in log book
  - Obligation to carry and maintain adequate nautical charts and nautical publications

**4.2.5 RESPONSIBILITIES UNDER THE RELEVANT REQUIREMENTS OF THE INTERNATIONAL CONVENTION FOR THE PREVENTION OF POLLUTION FROM SHIPS**

Required Performance:

- .1 Annex I – Oil (1 hour)**
- Record of construction and equipment as supplement to the IOPP Certificate
  - Requirements for initial and periodical surveys
  - Requirements for periodical inspections and endorsements on the IOPP Certificate;
  - Maintaining Oil record book
  - Approved Shipboard Oil Pollution Emergency Plan (SOPEP)
- .2 Annex II – Noxious Liquid Substances in Bulk (1 hour)**
- Ships surveyed and certified in accordance with Noxious Liquid Substances in Bulk
  - International Bulk Chemical Code (IBC Code) or Bulk Chemical Code (BCH Code)
  - Duration of validity of certificate
- .3 Annex III – Harmful substances carried in packaged form (0.5 hour)**
- Ship should notify port 24 hrs in advance of intention to load or unload certain harmful substances
- .4 Annex IV – Sewage (0.5 hour)**
- International Sewage Pollution Prevention Certificate
  - Duration of Validity of Certificate
- .5 Annex V – Garbage (1 hour)**
- Garbage Management Plan
  - Garbage Record Book
  - Garbage disposal restrictions
- .6 Annex VI – Air Pollution (1 hour)**
- Exhaust emissions
  - Cargo vapour emissions
  - Ozone depleting Substances
  - International Air Pollution Prevention Certificate
  - Periodical and intermediate survey
  - Duration and validity of certificate
  - Regulation 13 regarding NO<sub>x</sub>

- NO<sub>x</sub> Technical Code
- Regulation 14 regarding SO<sub>x</sub>,
- Emission Control Areas
- Regulation 18 – Bunker delivery note and fuel oil sample

#### 4.2.6 MARITIME DECLARATIONS OF HEALTH AND THE REQUIREMENTS OF THE INTERNATIONAL HEALTH REGULATIONS

Required Performance:

- .1 WHO's International Health Regulations 2005 (IHR) (3 hours)**
  - Ship Sanitation Certificates for prevention and control of public health risks on board ships on international voyages
  - Issue of Ship Sanitation Control Exemption Certificate (SSCEC) or a Ship Sanitation Control Certificate (SSCC)
  - Ship Sanitation Certificates in two parts - Part A and Part B
  - Environmental issues, such as the discharge by ships of sewage, waste and ballast water, which may constitute public health risks, will be also addressed in this Ship Sanitation Certificates
  - Validity and extension of SSCEC and SSCC
  - Maritime Declaration of Health
    - Identification of the ship;
    - List of ports of call within past 30 days;
    - List of crew members and travelers within past 30 days;
    - Validity of the existing Ship Sanitation Certificates and whether re-inspection is required
    - Affected areas visited.
  - International Certificate of Vaccination or Prophylaxis
  - Following additional sources of information may be required, if appropriate, for public health risk assessment purposes:
    - Management Plans for, e.g. water bunkering, food safety, pest control, sewage, waste.
    - Ballast Water Form IMO A (868)20.
    - Medical log, regarding information about incidences on board the ship which might constitute health events under IHR.
    - List of medicine, provides information about what kinds and amounts of medicines are carried in the medical chest.
    - Potable Water Analysis Report provides results of microbiological examination and/or chemical analysis of potable water.
- .2 International Medical Guide for Ships (IMGS) and recommendations for the ship's medicine chest and equipment (1 hour)**
- .3 International Maritime Organization's Medical First Aid Guide for Use in Accidents Involving Dangerous Goods (MFAAG) (0.5 hour)**
- .4 WHO's Guidelines for Drinking-water quality (0.5 hour)**



---

**4.2.7 RESPONSIBILITIES UNDER INTERNATIONAL INSTRUMENTS AFFECTING THE SAFETY OF THE SHIPS, PASSENGERS, CREW OR CARGO**

Required Performance:

- .1 ILO's Maritime Labour Convention 2006 (MLC 2006) (4 hours)**
  - MLC 2006 updates more than 65 international labour standards related to seafarers adopted over the last 80 years
  - MLC 2006 will enter into force 12 months after ratifications by at least 30 Members with a total share in the world gross tonnage of ships of 33 per cent
  - MLC 2006 is organized into three main parts:
    - Articles set out the broad principles and obligations.
    - More detailed Regulations and Code (with two parts: Parts A and B) provisions.
    - Regulations and the Standards (Part A) and Guidelines (Part B) in the Code are integrated and organized into general areas of concern under five Titles:
      - ❖ Title 1: Minimum requirements for seafarers to work on a ship
      - ❖ Title 2: Conditions of employment
      - ❖ Title 3: Accommodation, recreational facilities, food and catering
      - ❖ Title 4: Health protection, medical care, welfare and social security protection
      - ❖ Title 5: Compliance and enforcement.
  - Maritime Labour Certificate and a Declaration of Maritime Labour Compliance issued by flag state under MLC 2006
  
- .2 Convention on the International Regulations for Preventing Collisions at Sea (COLREG) 1972 (1 hour)**
  
- .3 International Convention on Salvage, 1989 – Lloyd's Standard Form of Salvage Agreement (LOF, 2000) (1 hour)**
  
- .4 Convention on Limitation of Liability of Maritime Claims, 1976 (LLMC 1976) (1 hour)**
  
- .5 International Convention for the Unification of Certain Rules of Law Relating to Bills of Lading, as Amended by Protocol of 1968 (Hague-Visby Rules) (1 hour)**
  
- .6 Charter parties (3 hours)**
  - Voyage charter
  - Time charter
  - Bareboat charter
  - Laydays and cancelling date (Laycan)
  - Notice of readiness (NOR)
  - Demurrage

- Dispatch
- Delivery – On hire
- On hire survey
- Redelivery – Off hire
- Off hire survey

**.7 Marine Insurance, General Average and P & I Club (4 hours)**

- Necessity of marine insurance
- Basic Principles of Marine Insurance
- Types of marine losses
  - Actual Total Loss and Constructive Total Loss
  - Partial Loss or Particular Average
  - General Average (Loss) - (GA)
- Hull and machinery insurance - Institute Time Clauses – Hulls 1.11.95 and International Hull clauses (01/11/02)
- Risks not covered by Hull and machinery policy
- Oil pollution liabilities
- P&I insurance – unique: no profit no loss
- P&I Club Insurance cover
  - Crew
  - Personal injury to or loss of life of stevedores
  - Personal injury to or illness or loss of life of passengers and others
  - Loss of personal effects
  - Diversion expenses
  - Life salvage
  - One-fourth collision liability
  - Oil pollution - Standard Oil Pollution Cover and Oil pollution cover for U.S.A.
  - Liabilities under contracts and indemnities
  - Wreck liabilities
  - Cargo liabilities
  - Fines
  - Legal costs
  - "Omnibus" cover

**4.2.8 METHODS AND AIDS TO PREVENT POLLUTION OF THE ENVIRONMENT BY SHIPS**

Required Performance:

**.1 List of Convention – (Refer 4.2.1.4 under "Conventions related to Marine Pollution")**

**.2 Sources of Marine pollution (1 hour)**

- Oil,
- Noxious liquid substances carried in bulk
- Harmful substances carried by sea in packaged form
- Sewage

- Garbage
- Air
- Ballast water
- Anti-fouling paints
- Noise

**.3 Effects of marine oil spills (1 hour)**

**.4 Regulations for prevention of oil pollution as per Annex I of MARPOL 73/78 (4 hours)**

- Tanks for oil residues (Sludge)
- Oily water separator and oil filtering equipment and oil content monitoring
- Standard discharge connection
- Control of oil discharge – discharge in special areas and outside special areas
- Oil record book
- Requirement for oil tankers
  - Double hull and double bottom tank
  - Intact stability requirements
  - Subdivision and damage stability
  - Slop tanks
  - Pumping, piping and discharge arrangements
  - Oil monitoring and control system
  - Requirements for crude oil washing
  - Control of discharge of oil from oil tankers - Discharge outside special areas and Discharge in special areas
  - Shipboard oil pollution emergency plan
  - Reception facilities
  - Concept of Integrated Bilge Water Treatment System (IBTS)

**.5 Regulations for control of pollution from Noxious liquid substances carried in bulk as per Annex II of MARPOL 73/78 (1 hour)**

- The following Codes are made mandatory by MARPOL 73/78 and SOLAS 74 and provide an international standard for the safe carriage by ships of dangerous cargoes, liquefied gases and noxious chemicals in bulk.
  - The International Code for the Construction and Equipment of Ships Carrying Dangerous Chemicals in Bulk (IBC Code), the Code for the Construction and Equipment of Ships Carrying Dangerous Chemicals in Bulk (BCH Code) and the Code for the Construction and Equipment of Ships Carrying Liquefied Gases in Bulk (IGC Code)

**.6 Regulations for the Prevention of Pollution by Harmful substances carried by sea in packaged form as per Annex III of MARPOL 73/78 (0.5 hour)**

- .7 Requirements covering the carriage of dangerous goods by sea as per chapter VII of the SOLAS Convention (0.5 hour)**
- Carriage of dangerous goods in packaged form and IMDG Code
  - Carriage of dangerous goods in solid form in bulk
  - Although the main concern of Chapter VII of SOLAS and the IMDG Code is safety, successful application of their provisions benefits the marine environment-by reducing pollution from harmful substances.
- .8 Regulations for the Prevention of Pollution by Sewage from Ships as per Annex IV of MARPOL 73/78 (2 hours)**
- Harmful effects of sewage to the marine environment
  - sewage treatment plant; system to comminute and disinfect the sewage; and a holding tank
  - standard discharge connections
  - discharge of sewage
  - reception facilities
- .9 Regulations for the Prevention of Pollution by Garbage from Ships as per Annex V of MARPOL 73/78 (2 hours)**
- placards, garbage management plans and garbage record keeping
  - shipboard incinerators
  - disposal of garbage outside special areas
  - disposal of garbage within special areas
  - reception facilities
- .10 Regulations for the Prevention of Air Pollution as per Annex VI of MARPOL 73/78 (3 hours)**
- Use of ozone depleting substances prohibited on ships. Use of HCFCs permitted till 1st January 2020
  - Sulphur content of any fuel oil used on board ships shall not exceed 4.5% m/m and a progressive reduction in sulphur initially to 3.50% effective from 1 January 2012; then progressively to 0.50%, effective from 1 January 2020, subject to a feasibility review to be completed no later than 2018.
  - The sulphur content limits applicable in Sulphur Emission Control Areas is 1.00% and will be further reduced to 0.10%, effective from 1 January 2015 or an exhaust gas cleaning system, approved by the Administration
  - Bunker delivery notes and representative sample to be retained
  - NO<sub>x</sub> technical file on board ship as per NO<sub>x</sub> Technical Code 2008 for all marine diesel engines with a power output of 130 kW or more
  - Vapour collection system for tankers for control of volatile organic compounds
  - Shipboard incineration and guidelines for use of incinerator

**.11 International Convention for the Control and Management of Ship's Ballast Water and Sediments (2 hours)**

- Ballast water treatment or exchange, depending upon year of built and size of ship
- Ballast Water Management Plan
- Ballast Water Record Book
- All ships using ballast water exchange should whenever possible, conduct ballast water exchange at least 200 nautical miles from the nearest land and in water at least 200 metres in depth

**.12 Anti-fouling paints (1 hour)**

- Ships could no longer be coated with TBT-based antifouling and those vessels coated with it should have them removed or have a barrier coating to prevent their leaching

**.13 Noise (1 hour)**

- IMO Assembly resolution A468 (XII) – Code on noise levels on board ships

**4.2.9 NATIONAL LEGISLATION FOR IMPLEMENTING INTERNATIONAL AGREEMENTS AND CONVENTIONS**

Refer to Guidelines.

**COMPETENCE 4.3 MAINTAIN SAFETY AND SECURITY OF THE VESSEL, CREW AND PASSENGERS AND THE OPERATIONAL CONDITION OF THE LIFE SAVING, FIRE FIGHTING AND OTHER SAFETY SYSTEMS**

**TRAINING OUTCOMES:**

Demonstrates a knowledge and understanding of:

**4.3 MAINTAIN SAFETY AND SECURITY OF THE VESSEL, CREW AND PASSENGERS AND THE OPERATIONAL CONDITION OF THE LIFE SAVING, FIRE FIGHTING AND OTHER SAFETY SYSTEMS.**

**4.3.1 LIFE SAVING APPLIANCES REGULATIONS ( SOLAS )**

**4.3.2 ORGANISATION OF FIRE AND ABANDON SHIP DRILL**

**4.3.3 MAINTENANCE OF LIFE-SAVING, FIRE-FIGHTING AND OTHER SAFETY SYSTEMS**

**4.3.4 ACTIONS TO BE TAKEN TO PROTECT AND SAFEGUARD ALL PERSONS ON BOARD IN EMERGENCIES**

**4.3.5 ACTION TO LIMIT DAMAGE AND SALVE THE SHIP FOLLOWING FIRE, EXPLOSION, COLLISION OR GROUNDING**

**COMPETENCE 4.3 MAINTAIN SAFETY AND SECURITY OF THE VESSEL, CREW AND PASSENGERS AND THE OPERATIONAL CONDITION OF THE LIFE SAVING, FIRE FIGHTING AND OTHER SAFETY SYSTEMS**

**4.3.1 LIFE SAVING APPLIANCES REGULATIONS (SOLAS)**

Required Performance:

- .1 Life-saving appliances and arrangements (Chapter III of SOLAS) and Life Saving Appliance Code (2 hours)**

**4.3.2 ORGANISATION OF FIRE AND ABANDON SHIP DRILL**

Required Performance:

- .1 Organisation of Fire and Abandon Ships Drills (1 hour)**

**4.3.3 MAINTENANCE OF LIFE-SAVING, FIRE-FIGHTING AND OTHER SAFETY SYSTEMS**

Required Performance:

- .1 Maintenance of Life-saving, Fire-fighting and Other Safety Systems (3 hours)**

**4.3.4 ACTIONS TO BE TAKEN TO PROTECT AND SAFEGUARD ALL PERSONS ON BOARD IN EMERGENCIES**

Required Performance:

- .1 Actions to protect and safeguard all persons on board in emergencies; Rescue of persons from a vessel in distress or from a wreck; and Man overboard procedures (1 hour)**

**4.3.5 ACTION TO LIMIT DAMAGE AND SALVE THE SHIP FOLLOWING FIRE, EXPLOSION, COLLISION OR GROUNDING**

Required Performance:

- .1 Contingency plans for response to emergencies (1 hour)**
- .2 Means of limiting damage and salvaging the ship following a fire or explosion (1 hour)**
- .3 Procedures for abandoning ship (1 hour)**

**COMPETENCE 4.4    DEVELOP EMERGENCY AND DAMAGE CONTROL PLANS AND  
HANDLE EMERGENCY SITUATION**

**TRAINING OUTCOMES:**

Demonstrates a knowledge and understanding of:

**4.4    DEVELOP EMERGENCY AND DAMAGE CONTROL PLANS AND HANDLE  
EMERGENCY SITUATION**

**4.4.1    SHIP CONSTRUCTION, INCLUDING DAMAGE CONTROL**

**4.4.2    METHODS AND AIDS FOR FIRE PREVENTION, DETECTION AND  
EXTINCTION**

**4.4.3    FUNCTIONS AND USE OF LIFE-SAVING APPLIANCES**



## **COMPETENCE 4.4 DEVELOP EMERGENCY AND DAMAGE CONTROL PLANS AND HANDLE EMERGENCY SITUATION**

### **4.4.1 SHIP CONSTRUCTION, INCLUDING DAMAGE CONTROL**

Required Performance:

**Refer to 4.1.1**

### **4.4.2 METHODS AND AIDS FOR FIRE PREVENTION, DETECTION AND EXTINCTION**

Required Performance:

#### **.1 Fire-fighting equipment (3 hours)**

- Construction, installation and operation of fixed fire fighting installations
- Construction, installation and operation of portable and semi portable fire-fighting equipment

### **4.4.3 FUNCTIONS AND USE OF LIFE-SAVING APPLIANCES**

Required Performance:

#### **.1 Life-saving appliances (2 hours)**

- Construction, installation and operation of life saving equipment
- Tests, procedures and maintenance necessary to ensure correct and safe operation of life-saving and other safety equipment
- Maintenance of water tight doors.

## **COMPETENCE 4.5 USE LEADERSHIP AND MANAGERIAL SKILLS**

### **TRAINING OUTCOMES:**

Demonstrates a knowledge and understanding of:

#### **4.5 USE LEADERSHIP AND MANAGERIAL SKILLS**

##### **4.5.1 KNOWLEDGE OF SHIPBOARD PERSONNEL MANAGEMENT AND TRAINING**

##### **4.5.2 KNOWLEDGE AND ABILITY TO APPLY EFFECTIVE RESOURCE MANAGEMENT**

##### **4.5.3 KNOWLEDGE AND ABILITY TO APPLY DECISION-MAKING TECHNIQUES**

##### **4.5.4 DEVELOPMENT, IMPLEMENTATION, AND OVERSIGHT OF STANDARD OPERATING PROCEDURES**

## **COMPETENCE 4.5 USE LEADERSHIP AND MANAGERIAL SKILLS**

### **4.5.1 KNOWLEDGE OF SHIPBOARD PERSONNEL MANAGEMENT AND TRAINING**

Required Performance:

- .1 Engineer and Manager (1 hour)**
  - Definition of management
  - Functions, characteristics and skills of engineers, supervisor and managers.
  
- .2 Human Resource Management (1 hour)**
  - Crew management
  
- .3 Training and Development (2 hours)**
  - Staff appraisal
  - Training needs analysis
  - Planning and organisation of training programmes
  - Training methods
  - Debriefing after training exercises
  - Evaluation of training programmes.
  
- .4 Maintenance Management (2 hours)**
  - Maintenance techniques
  - Machinery maintenance and surveys planning and organisation
  - An insight into Reliability Centred Maintenance

### **4.5.2 KNOWLEDGE OF INTERNATIONAL MARITIME CONVENTIONS AND RECOMMENDATIONS AND RELATED NATIONAL LEGISLATIONS**

Required Performance:

- .1 The ISM Code (Refer to 4.2.4.1)**
  
- .2 STCW Convention (1 hour)**
  - Hours of work and hours of rest
  
- .3 ILO's MLC 2006 (Refer to 4.2.7.1/2/3/4)**

#### 4.5.3 ABILITY TO APPLY TASK AND WORKLOAD MANAGEMENT

Required Performance:

- |           |  |                 |
|-----------|--|-----------------|
| <b>.1</b> | <b>Communication</b>   | <b>(1 hour)</b> |
|           | <ul style="list-style-type: none"><li>○ Verbal and non-verbal communication.</li><li>○ Report writing. Presentation.</li><li>○ Group discussion.</li><li>○ Meetings.</li></ul> |                 |
| <b>.2</b> | <b>Team Building</b>   | <b>(1 hour)</b> |
|           | <ul style="list-style-type: none"><li>○ Importance of work teams.</li><li>○ Group dynamics.</li><li>○ Approaches to team building. Committees.</li></ul>                       |                 |
| <b>.3</b> | <b>Planning and Co-ordination</b>  | <b>(1 hour)</b> |
| <b>.4</b> | <b>Personal assignments</b>  | <b>(1 hour)</b> |
| <b>.5</b> | <b>Time and resource constraints</b>   | <b>(1 hour)</b> |
| <b>.6</b> | <b>Prioritization</b>  | <b>(1 hour)</b> |

#### 4.5.4 KNOWLEDGE AND ABILITY TO APPLY EFFECTIVE RESOURCE MANAGEMENT

Required Performance:

- |           |  |                 |
|-----------|--|-----------------|
| <b>.1</b> | <b>Allocations, assignment and prioritization of resources</b> | <b>(1 hour)</b> |
| <b>.2</b> | <b>Effective communications on board and ashore</b>            | <b>(1 hour)</b> |
| <b>.3</b> | <b>Decisions reflect consideration of team experience</b>      | <b>(1 hour)</b> |

#### 4.5.5 KNOWLEDGE AND ABILITY TO APPLY DECISION-MAKING TECHNIQUES

Required Performance:

- |           |   |                  |
|-----------|---|------------------|
| <b>.1</b> | <b>Management Processes and Functions</b>   | <b>(2 hours)</b> |
|           | <ul style="list-style-type: none"><li>○ Management processes</li><li>○ Management functions</li><li>○ Motivation</li><li>○ Conflict resolution.</li></ul> |                  |

**.2 Negotiating Skills (2 hours)**

- Negotiation process.
- Necessary skills for successful negotiation.
- Planning for negotiation.

**.3 Situation and risk assessment (1 hour)**

**.4 Identify and generate options (1 hour)**

**.5 Select course of action (1 hour)**

**.6 Evaluation of outcome effectiveness (1 hour)**

**4.5.6 DEVELOPMENT, IMPLEMENTATION, AND OVERSIGHT OF STANDARD OPERATING PROCEDURES**

Required Performance:

**.1 Project Planning and Controlling (3 hours)**

- Project planning and controlling process
- GANTT charts
- Critical Path Method
- Programme Evaluation and Review Techniques
- Application of Fault Tree Analysis and similar Reliability Engineering Techniques to solve practical shipboard problems.

## **Part D4: Instructor Manual**

### **Function 4: Controlling the Operation of the Ship and Care for Persons on Board at the Management level**

#### **■ Guidance Notes**

The following notes are intended to highlight the main objectives or training outcomes of each part of the function. The notes also contain some material on topics which are not adequately covered in the quoted references.

On completion of training for this function officers will have a knowledge of the principal structural members of a ship and methods of construction. They will understand the theory of stability and trim and be able to use tables, diagrams and stress calculators to plan loading and ballasting so as to maintain satisfactory stability and trim (taking account of applicable IMO recommendations concerning intact stability) and to ensure that hull stresses remain within acceptable limits.

The effects of damage to, and the consequent flooding of, a compartment on the trim and stability of a ship and the counter-measures to be taken will be understood.

Officers will also be thoroughly conversant with the certificates required to be on board, their periods of validity and the procedures for their renewal.

The officers will also be aware of their legal obligations and responsibilities concerning international provisions for the safety of the ship, crew, passengers and cargo and for the prevention of pollution from the ship.

They will also be able to follow the correct procedures for all matters concerning the crew; their engagement and discharge, treatment of wages and deductions, discipline and dealing with disciplinary offences, the discharge of a sick seaman abroad, repatriation, deceased seamen and engagement of substitutes.

Officers will have sufficient knowledge of shipping documents related to cargo and the shipowner's liabilities and obligations in respect of charter parties and the carriage of cargo to enable them to protect the ship's interests.

Officers will be capable of organizing and managing the crew for the safe and efficient operation of the ship and be able to draw up an organization for dealing with emergencies. Officers will also know the requirements for training in the operation and maintenance of safety equipment and be able to implement that training on board.

On completion of training for this function officers will be able to use plans and tables or diagrams of stability and trim data to calculate the ship's initial stability, draughts and trim for any given disposition of cargo and other weights. They will also be able to determine whether stresses on the ship are within permitted limits by the use of

stress data, calculating equipment or software. The fundamental actions to take in the event of partial loss of intact buoyancy will be understood.

## **4.1 CONTROL TRIM, STABILITY AND STRESS**

### **4.1.1 FUNDAMENTAL PRINCIPLES OF SHIP CONSTRUCTION AND THE THEORIES AND FACTORS AFFECTING TRIM AND STABILITY AND MEASURES NECESSARY TO PRESERVE TRIM AND STABILITY**

#### **4.1.1.1 Ship Types and Terms (4 hours)**

Trainees should be able to explain the various ship types such as: passenger ships, cargo liners, oil tankers, bulk carriers, container ships, roll-on/roll-off vessels, liquefied gas carriers, chemical carriers; Secondly, trainees should be able to identify the common terms used in ships measurements such as: after perpendicular, forward perpendicular, length overall, length between perpendiculars, breadth extreme, breadth moulded, depth extreme, depth moulded, draught extreme, draught moulded, freeboard, camber, sheer, rise of floor, bilge radius, tumble home, flare, stem rake, keel rake, entrance, run, displacement, lightweight, deadweight; Thirdly, trainees should be able to explain the Tonnage and Load line rules applicable to ships. Instructors should refer to the following text T4, T19, T25, R45, R44, B18, and V26 for clarification of the above topics.

#### **4.1.1.2 Stresses in Ship Structures (4 hours)**

Instructors should highlight to trainees the terms commonly associated with stresses and their causes that a ship encounters in various conditions. Instructors to use the following text to assist in their delivery: T4, T19, T25, T34. Terms includes: longitudinal bending, still water bending, and load diagram, shear force diagram, bending moment diagram, hogging, sagging, wave bending, transverse bending, docking, grounding, pounding, and panting.

#### **4.1.1.3 Ship Construction (30 hours)**

The instructor should refer to R1 (SOLAS Chap II) and also the following texts and teaching aids when preparing to deliver this section: T4, T19, T25, T33, T35, B97, B102, V27. Coverage should include: (i) Terms used to describe structural members: keel, bilge keel, duct keel, bottom plating, double bottom, tank top, girder, centre girder, side girder, floor, side frame, shell plating, deck plating, flanges, margin plate, longitudinal, intercostal, stiffener, web frame, bulkhead, collision bulkhead, panting stringer, stringer, pillars, garboard strake, sheer strake; (ii) the Double bottom construction, structural members used and purposes; (iii) duct keels.- purpose and safety features; (iv) Forward and after peak structures, reasons for the varying dimensions and members; (v) Anchor cable termination details; (vi) Longitudinal, transverse and combined framed vessels. (vii) Decks, Hatch covers, Bulwarks; (viii) Deep frames and design consideration for discontinuities in the vessel structure; (ix) Bilge keel consideration; (x) Strakes for the hull; (xi) Fittings through the hull requirements; (xii) Engine, deck machinery and stabilizer strengthening members; (xiii) Bulkhead construction and their position; (xiv) Requirements for maintaining of

strength and watertight integrity when bulkheads are pierced for normal operation; (xv) the rudder and its supporting arrangements; (xvi) Stern frame; (xvii) Design criteria for specialised ships; (xviii) Structural fire protection, its classes and requirements; (xix) Ship's General arrangement drawing; (xx) Shell expansion; (xxi) Deck plan and ship's midship section construction

#### **4.1.1.4 Ship Dynamics** **(2 hours)**

Instructors should refer to the following text for reference, T4, T25, T19, T35, T34 and should address these areas: (i) Ship motions-Rolling, - Pitching, -Heaving; (ii) Bilge keels; (iii) Fin Stabilizers; (iv) Passive and active anti-roll tanks; (v) Vibration.

#### **4.1.1.5 Hydrostatics** **(3 hours)**

Instructors should refer to text T3 to cover the following: Density, Relative density, Pressure exerted by a liquid, Load on an immersed plane, Centre of pressure, Load diagram, Shearing force on bulkhead stiffeners.

#### **4.1.1.6 Displacement, TPC, Coefficients of Form** **(3 hours)**

Instructors should consult texts T3, T34, T35, to explain the following to trainees: (i) Archimedes' principle; (ii) Displacement; (iii) Tonne Per Centimetre immersion ( TPC); (iv) Block coefficient; (v) Prismatic coefficient; (vi) Midship coefficient; (vii) Waterplane area coefficient; (viii) Wetted surface area; (ix) Similar figures; (x) Influence of hull form on coefficients.

#### **4.1.1.7 Areas and Volumes of Ship Shapes, First and Second Moments** **(10 hours)**

Instructors should refer to text T3, T19, T34, to explain and also solve problems using: (i) Simpson's 1st and 2nd Rules for areas and volumes; (ii) Application of 'Simpson's rules' to calculate areas and volumes; (iii) Common areas such as waterplanes, sections and bulkheads; (iv) Immersed volume of hull by sections and waterplanes; (v) Simpson's 1st and 2nd Rules for 1st moments and centroid; (vi) Application of Simpson's Rules to find centroids; (vii) Centroids of common areas such as, waterplanes, sections and bulkheads; (viii) Vertical Centre of Buoyancy, VCB; Longitudinal Centre of Buoyancy, LCB; (ix) Simpson's 1st and 2nd Rules for 2nd moments of area; (x) Application of Simpson's Rules to find 2nd moments of area; (xi) Transverse moment of inertia,  $I_T$ ; Longitudinal moment of inertia,  $I_L$ .

#### **4.1.1.8 Centres of Gravity** **(3 hours)**

Instructors should consult texts T3, T34, T35, to explain to trainees and use examples to calculate: (i) Longitudinal and Vertical centre of gravity; (ii) Shift in centre of gravity due to the addition, removal or transfer of masses; (iii) Effect of a suspended mass.

#### **4.1.1.9 Transverse Stability** **(7 hours)**

Instructors should refer to the following texts B3,B115, T3, T28,R54 V50, V51 to explain to trainees and use examples to calculate: (i) Vertical centre of buoyancy; (ii) Hydrostatic tables; (iii) Transverse metacentric height, GM; (iv) Righting lever, GZ; (v) Stability at small angles of heel; (vi) Metacentric diagram; (vii) Inclining experiment; (viii) Free surface effect; (ix) Stability at large angles of heel; (x) Cross curves of stability, KN Tables; (xi) Curve of statical stability; (xii) Dynamical stability; (xiii) Angles of loll, list.

Such areas to be covered may include: Stability at moderate and large angles of heel  
The equation  $BM = \frac{I}{V}$  has been quoted partly to show that the BM is a function of the ship's dimensions and state of loading and partly to explain the typical behaviour of KM as the draught is increased from light ship conditions. Use is also made of the equation in the treatment of damage stability. The proof of the equation is not required.

GZ curves will normally be constructed from KN curves, but trainees should be able to correct a GZ curve when the value of KG differs from that used in drawing the curve, either by drawing a new curve or by superimposing the curve of  $GG_1 \sin$  (angle of heel) on the original. The initial GM should be used as an aid to constructing the curve at small angles of heel. Trainees should not be expected to deduce the GM from a given curve.

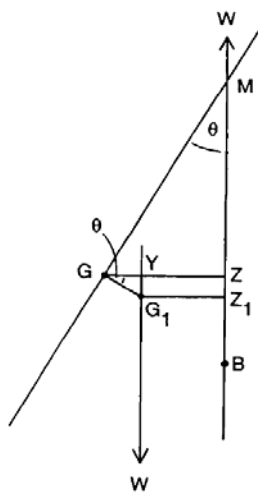

Figure 1

Figure 1 shows a ship with its centre of gravity,  $G_1$ , at a distance  $GG_1$  horizontally from the centreline. When inclined to an angle  $\theta$ , the righting lever is  $G_1Z_1$ .

$$\begin{aligned} G_1Z_1 &= GZ - GY \\ &= GZ - GG_1 \cos \theta \end{aligned}$$



The values of  $GZ$  derived from KN curves can be reduced to  $GG_1 \cos \theta$  before plotting or the curve  $GG_1 \cos \theta$  can be superimposed on the  $GZ$  curve, as shown in Figure 2.

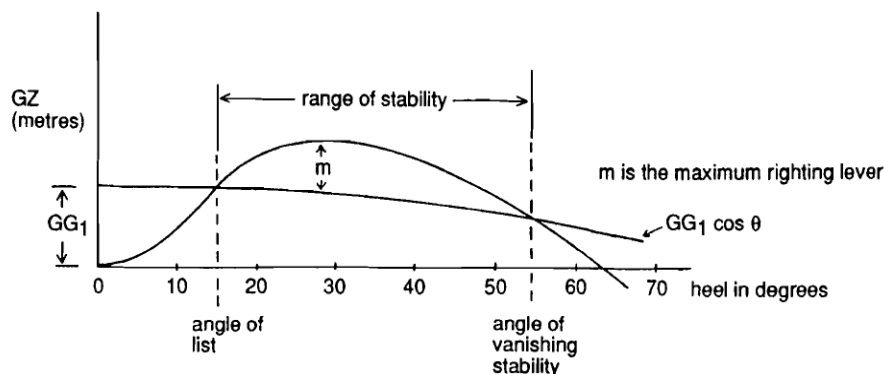

**Figure 2**

A list reduces the righting levers and the range of stability when heeled towards the listed side. When heeled in the opposite direction, righting levers are increased.

#### 4.1.1.10 Trim

**(4 hours)**

Trim calculations using moments about the centre of flotation or trimming tables. These methods are suitable only in cases where the change in displacement is sufficiently small so that there are no large changes in the position of the centre of flotation or the value of MCT. When large changes in displacement are involved, as, for example, in planning the loading of a ship, the following method should be used.

The Figure below shows a ship on an even keel with longitudinal centres of buoyancy and gravity indicated. The weight and buoyancy forces form a couple, called the trimming moment, equal to the product of the displacement and the horizontal separation between  $B$  and  $G$ , in this case acting to trim the ship by the stern. The ship will trim until the centre of buoyancy of the new underwater volume is in the same vertical line as  $G$ , which is fixed.

The trim is given by  $\frac{\text{trimming moment}}{\text{MCT 1cm}}$  where the MCT is taken for the displacement of the ship.

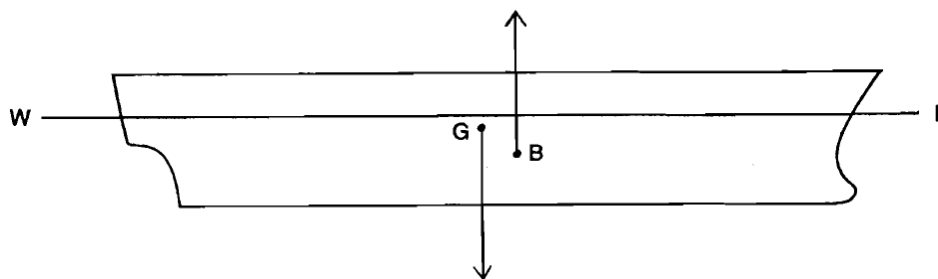

**Figure 3**

The position of the longitudinal centre of buoyancy (LCB), for an even-keel condition, depends upon the ship's draught and is given in the hydrostatic data as a distance, either from the after perpendicular or from amidships.

The position of the longitudinal centre of gravity is found by taking moments of mass, about the after perpendicular or about amidships, of the light ship and all of its contents. The LCG for the light ship is included in the hydrostatic data. LCG's of tanks and holds are given in the capacity plans or can be measured from the profile plan.

To find the draughts at each end, the trim is divided in the usual way, according to the proportionate distances of the perpendiculars from the centre of flotation, and applied to the ship's true mean draught.

When a ship is hogged or sagged there is a difference between the mean draught calculated from the draughts at the ends and the draught amidships. The difference is the amount of hog or sag. Taking the case of a ship with a sag, the draught amidships is greater than the mean draught. The ship's displacement lies between the values obtained for the two draughts and corresponds to some intermediate draught.

A weighted average of the mean draught and draught amidships is used. The commonly used values are:

$$\text{corrected draught} = \frac{3}{4} \times \text{draught amidships} + \frac{1}{4} \times \text{mean draught};$$

or

$$\text{corrected draught} = \frac{2}{3} \times \text{draught amidships} + \frac{1}{3} \times \text{mean draught}.$$

These amount to applying  $\frac{1}{4}$ , in the first case, or  $\frac{1}{3}$ , in the other, of the hog or sag to the amidships draught.

A method known as the mean of mean of means is sometimes used. The mean of the forward and after draughts is found, the mean of that and the draught amidships is found and the mean of that with the draught amidships again gives the required draught. The result is the same as for the first equation above.

Trainees should be able to understand and solve problems associated with: Centre of flotation; Mean draught; Longitudinal metacenter; Change in draughts due to added masses; Moment to Change Trim 1 centimetre; Change in draughts due to a change in density; Change in trim due to change in density.

#### **4.1.1.11 Stability during Drydocking and stability during grounding (2 hours)**

Trainees should understand the ship's stability when docking and on grounding. They should identify the critical conditions and calculate the stability and actions to be taken. Instructors should consult texts, T3, T28, R54, T34, and T36 when preparing for this topic.

When dealing with stability during dry-docking, it is simplest to consider the righting moment when heeled by taking moments about the centre of buoyancy, which produces the equation:

$$\text{righting moment} = \Delta \times GM \sin \theta - P \times KM \sin \theta$$

directly.

The righting lever, GZ, is given by the equation:

$$GZ = (GM - \frac{P \times KM}{\Delta}) \sin \theta,$$

which is the righting lever for the ship with its GM reduced by  $\frac{P \times KM}{\Delta}$ .

By making use of  $KM = KG + GM$ , the alternative expression for righting lever can be obtained. This approach has the advantage of showing that, although different values of GM are obtained, the value of the righting moment is the same in each case. The value of P for which  $GM = 0$  is also the same for both expressions.

The stability of a ship grounded at a point on the centreline is treated in exactly the same way as the dry-docking problem. A ship grounded forward, say, on a falling tide, would experience a reducing righting lever and the point could be reached at which it became zero. Providing the ship did not touch bottom elsewhere, it would flop over to an angle of loll or possibly capsize.

When grounded at a point off the centreline, a heeling moment is also produced. Considering the case where only heeling moment is involved, at the point of capsize the up thrust from the bottom becomes zero, therefore the ship would not capsize until heeled to its angle of vanishing stability when afloat. In most circumstances, cargo would have shifted, water entered through non-watertight openings or the ship would have slid off before reaching that angle. When the grounding force causes trim as well as heel the angle of vanishing stability may be much smaller.

It should be recalled that buoyancy is provided by the vertical component of water pressure on the ship's hull. When a ship is grounded on firm sand or a bottom of similar nature, water is unable to exert any pressure on the grounded portion and there is a loss of buoyancy compensated by an increased up thrust from the ground. If a ship is grounded over the whole of its bottom there is a large loss of buoyancy for any drop in water level, however small. Stability is not a problem in that circumstance but the fact that nearly all the weight of the ship is supported by the ground must be considered when deciding how to refloat her.

#### **4.1.1.12 Resistance and Fuel Consumption**

**(5 hours)**

Instructors should refer to the following texts T3,B115, T34, T28, for explanation of the following: (i) Frictional resistance; (ii) Reynolds' number; (iii) Residuary resistance; (iv) Froude number; (v) Speed length ratio; (vi) Effective power; (vii) Admiralty coefficient;

(viii) Fuel coefficient and fuel consumption. Trainees should be able to know how to solve problems involving the above variables.

#### 4.1.1.13 Propellers and Power

(5 hours)

Trainees should know the terms used to describe propulsion systems such as: propeller diameter, pitch, pitch ratio, theoretical speed, apparent slip, wake fraction, real slip, projected area, developed area, blade area ratio, disc area ratio. Also trainees should be familiar with terms used in the calculation of power such as: thrust power, shaft power, delivered power, thrust deduction factor, effective power, quasi-propulsive coefficient. Trainees should be able to solve propeller and power problems. They should also understand cavitation, the measurement of pitch and ship trials. Instructors should consult T3, T19, T34, T35, B102, and B115

Propeller theory is quite complicated, and, as the chief engineer has no influence on its design, reference to this is intended to give only sufficient knowledge for operational purposes.

A diagram similar to that shown below may be useful to cover the above objective.

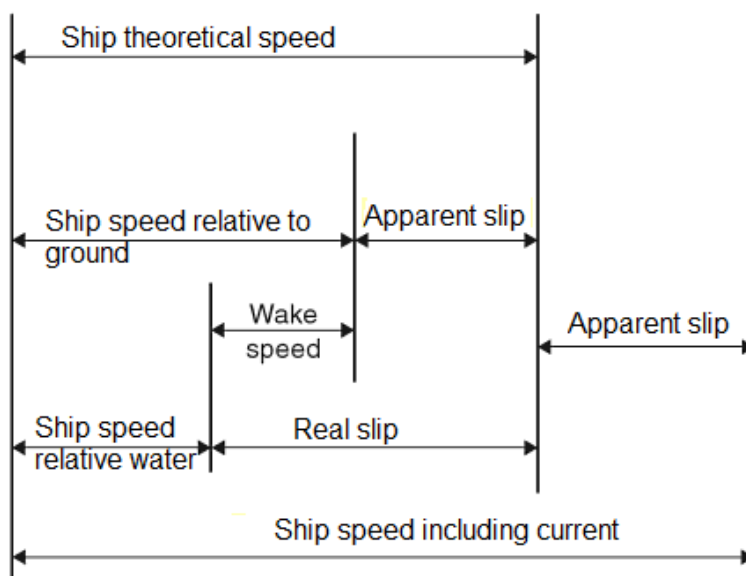

Figure 4

A ship's speed over the ground increases if there is a following current and the apparent slip reduces (it could become negative)

#### 4.1.1.14 Rudders

(2 hours)

Instructors should refer to the following texts T3, B115, T34, T28, for the explanation of the following: (i) Force on a rudder and Torque on a rudder stock; (ii) Angle of heel due to force on rudder; (iii) Angle of heel when turning.

#### 4.1.2 EFFECT ON TRIM AND STABILITY IN EVENT OF DAMAGE TO AND CONSEQUENT FLOODING OF A COMPARTMENT AND COUNTERMEASURES TO BE TAKEN

##### 4.1.2.1 Effect of flooding on transverse stability and trim (5 hours)

Trainees should be capable of assessing the stability and trim of a vessel in the effect of flooding. Instructors should consult T4, T19, T34, B3, and B102 for information on: (i) Grounding, damage and bilging; (ii) Bilging amidships, side compartment, and end compartment; (iii) Effect of bilging on stability (draft, trim, list and GM)

The International Convention on Load Lines lays down requirements for the survivability of ships of type 'A', if over 150 metres in length and for ships of type 'B' which are over 100 metres in length and are assigned freeboards less than the tabular freeboards for type 'B' ships.

Classification society rules stipulate the minimum number of bulkheads to be fitted in dry cargo ships, depending upon length, but do not specify that they should be fitted in such a way that the ship could withstand flooding of a main compartment.

Proposed amendments to the SOLAS Convention will provide regulations governing the subdivision and damage stability of cargo ships. They will apply to ships over 100 metres in length intended primarily for the carriage of dry cargoes, but will exclude those ships already covered by other damage stability regulations in IMO instruments.

The proposed regulations are based on consideration of the probability of the location and extent of damage and the probability of survival after damage. The probabilities of survival conditional upon each possible damage configuration for compartments, singly or in adjacent groups, are summed for the summer draught and for a draught intermediate between light and loaded. The average of the two sums gives a value known as the "attained subdivision index, A" which must not be less than the "required subdivision index, R", which is a function of the length.

When a space is flooded without free communication with the sea, the stability can be calculated by taking account of the mass of water and the free surface effect. Examples would be the accumulation of water in 'tween-decks as a result of fire fighting, or flooding through a crack in the hull or through a fractured pipe. The ship's hydrostatic data for the increased displacement are applicable for the calculations.

If a compartment is holed so that water can flow freely in and out of it, that compartment can be considered as part of the sea and no longer part of the ship. The buoyancy of the space up to the water level before damage is lost and the waterplane area of the ship is reduced by the waterplane area of the damaged compartment. These changes give rise to changes in the hydrostatic data needed to calculate the transverse stability and trim. The mass of the ship and its centre of gravity remain unaltered. Such a treatment is known as the 'lost buoyancy method' and is the one used in this course and in the textbook T11.

The lost buoyancy, expressed in tonnes, is the mass of water which could enter the space up to the original waterplane, i.e. the volume x permeability x density of water in which the ship is floating.

The lost waterplane area is the area of the bilged compartment at the original waterplane. If the compartment is completely contained below the waterline, e.g. a double-bottom tank, there is no loss of waterplane area provided the tank top remains intact. The original waterplane area may be given in the ship's data or it can be calculated from

$$\text{waterplane area} = \frac{100 \times \text{TPC}}{1.025}$$

Of the two corrections in this objective, the first is the second moment of lost waterplane area about its own centroid, the second a correction to give the loss about the new centroid of the intact waterplane. In the case of symmetrical flooding, the second correction is zero. For wing compartments, the second correction is very much greater than the first, even for compartments extending half the breadth of the ship.

Generally, the displacement of the ship and the position of the centre of gravity will remain unchanged after bilging. However, if a tank containing a liquid is bilged, the weight of the tank contents is lost, causing a reduction in displacement and a shift in the position of the ship's centre of gravity. The lost buoyancy would be comparable with the lost weight, causing a similar shift in the centre of buoyancy with the result that there would be little change of draught, trim or list. The loss of waterplane area would result in a reduction of GM.

The permeability of a space is the percentage or fraction of the space which could be occupied by water. The lost buoyancy equals the permeability x the volume. If a cargo was stowed solidly, with no space for water to infiltrate, it would occupy  $\frac{1 \text{ m}^3/\text{t}}{\text{density}}$

The space occupied in the hold by one tonne is its stowage factor, so the space available to water = stowage factor -  $\frac{1 \text{ m}^3/\text{t}}{\text{density}}$

The proportion of the stow which could be occupied by water, i.e. the permeability, equals stowage factor -  $\frac{1 \text{ m}^3/\text{t}}{\text{density}}$   
 $\frac{\text{stowage factor}}{\text{stowage factor}}$

For example, a cargo has a stowage factor of 1.2 m<sup>3</sup>/t and a density of 2.5 t/m<sup>3</sup>.

$$\frac{1}{\text{density}} = \frac{1}{2.5} = 0.4 \text{ m}^3/\text{t}$$

$$\text{permeability} = \frac{1.2 - 0.4}{1.2} = \frac{0.8}{1.2} = 0.67$$

Notice, if a cargo has a permeability of 0.4 but only occupies half of the compartment, the permeability of the whole compartment is  $0.4 \times 0.5 + 0.5 = 0.7$ .

The loss of waterplane area is taken to be permeability x waterplane area of the compartment, but if the water level is above the top of the cargo the whole area is lost.

Buoyancy is lost at the damaged compartment and an equal amount of buoyancy is gained at the position of the new centre of flotation. The transverse shift in the ship's centre of buoyancy is, therefore, lost buoyancy x transverse distance from centre of flotation divided by the displacement. On the assumption that the centre of gravity is still on the centreline, the shift in buoyancy is the heeling arm.

The angle of heel would be given by the intersection of the GZ curve for the damaged ship with the heeling-arm curve  $BB_1 \cos \theta$ . Since KN curves for the damaged condition are not available, the GZ curve has to be constructed, using values for the intact ship at a displacement corresponding to the damaged draught and a KG chosen to give the modified value of GM. The angle of heel read from the curve will be approximate. If the angle is small it can be calculated from,  $\tan \theta = \frac{BB_1}{GM}$

Similar calculations are necessary to find the longitudinal position of the centre of flotation after damage, and the reduction of  $BM_L$ . The change in  $GM_L$  is used to calculate the change in MCT 1cm.

Buoyancy has been lost at the damaged compartment and replaced at the centre of flotation, hence the trimming moment is the product of lost buoyancy and the distance from the centre of the damaged compartment to the new centre of flotation. The change of trim and the draught at each end are then calculated in the usual way.

Flooding of a compartment near an end of the ship causes a large shift in the centre of flotation away from the damaged end and a large reduction in MCT 1cm. Combined with the sinkage due to lost buoyancy, this may produce a large increase in draught at the damaged end. The original trim of the ship will influence the chances of the ship surviving the damage. A ship already trimmed towards the damaged end is more vulnerable than one on an even keel or trimmed the other way.

#### **4.1.2.2 Countermeasures to be taken**

**(2 hours)**

Instructors should convey to trainees countermeasures that need to be undertaken for – cross flooding of compartments and the effective use of the damage control plan, damage control booklet. Instructor should refer to T3, T19, T28, T34, B3, and B115 while planning their topic content.

The immediate action should be to restrict the flooding and, if possible, to stop it. In the event of collision or stranding damage, it will not be possible to stop the flooding or reduce it significantly by the use of pumps. Even a comparatively small hole below the waterline admits water at a much higher rate than the capacity of bilge or ballast pumps. All watertight doors, valves, dampers in ventilation shafts and access hatches should be closed to prevent flooding progressing to other compartments. Where cross-flooding arrangements are required, they should be put into operation at once to restrict the resulting list.

In passenger ships, the guidance in the damage control booklet should be followed. The same applies to cargo ships where damage control information is provided.

In nearly all cases, damage will result in sinkage, list and trim, loss of stability and loss of longitudinal strength. Corrective action for one condition will affect the others.

Excessive list or trim should be corrected by moving weights, fuel, water or liquid cargoes, when possible. If ballast is added, it increases the sinkage. In some cases it may be possible to pump out ballast to improve list or trim and lighten the ship at the same time. If the ballast is taken from double-bottom tanks, however, the stability will be further reduced.

Stability may be improved by transferring fuel from wing or cross bunker tanks to double bottoms if suitable tanks are empty. Efforts should be made to reduce free surface to a minimum. Water accumulating in upper decks as a result of fire fighting should be drained to the lowest level possible if means of pumping it out of the ship cannot be arranged.

After collision or stranding damage, particularly near the middle length of the ship, the longitudinal strength will be impaired and account should be taken of that when deciding on the transfer or addition of weights.

Cases have occurred where a slow leakage of water has been absorbed by a cargo, such as grain, with no water reaching the drain wells. The added weight, high on one side of the hold, has led to a steadily increasing list and eventual capsizing. As the source of the leakage was inaccessible, nothing could be done. Cargo spaces should be thoroughly inspected whenever they are empty for signs of leakage, indicating cracks or damage to overside discharge valve covers.



#### **4.1.3 IMO RECOMMENDATIONS CONCERNING SHIP STABILITY**

##### **4.1.3.1 IMO recommendations concerning ship stability (3 hours)**

Trainees should know the recommendations relevant to Ship Stability in IMO's International Code of Intact Stability 2008. They should understand the importance of Damage Control plan and booklet and other available resources such as onboard computer softwares and company policy in emergency situation on how to address Ship Stability. Instructors should refer to R1, R54, B3, B102, for reference.

#### **4.2 MONITOR AND CONTROL COMPLIANCE WITH LEGISLATIVE REQUIREMENTS AND MEASURES TO ENSURE SAFETY OF LIFE AT SEA AND THE PROTECTION OF THE MARINE ENVIRONMENT**

##### **4.2.1 RELEVANT INTERNATIONAL MARITIME LAW EMBODIED IN INTERNATIONAL AGREEMENT AND CONVENTIONS**

###### **4.2.1.1 United Nations Convention on the Law of Sea 1982 (UNCLOS)(3 hours)**

Instructors should refer to the United Nations Convention on the Law of the Sea (UNCLOS); and text R1, to address the following: (i) Limits of territorial sea innocent passage in territorial sea; (ii) Freedom of high seas; (iii) Nationality of ships; (iv) Duties of flag state; (v) Penal jurisdiction in matters of collision or any other incident of navigation; (vi) Duty to render assistance; (vii) Measures to prevent, reduce and control pollution of the marine environment; (viii) Port state, coastal state and flag state jurisdiction; (ix) Criminal jurisdiction on board a foreign ship; (x) Civil jurisdiction in relation to foreign ships. Trainees should be able to describe what UNCLOS specifies about the ten points in the topic content.

###### **4.2.1.2 Treaties, conventions, protocols, rules and regulations (2 hours)**

Instructors should refer to relevant Law based text that clearly explains the following, how they are brought about, and their link to each other: Treaties; Conventions; Protocols; Adoption of convention; Signature, ratification, acceptance and approval; Accession; Amendments and tacit acceptance; Rules and regulations

###### **4.2.1.3 International Maritime Organization (IMO) (2 hours)**

Instructors should refer to the IMO publications and teaching aids to inform trainees the history of IMO, its formation, its purpose; IMO structure including the Assembly, Council and its various Committees and secretariat. Also the Codes and Recommendations that IMO has published should be discussed.

###### **4.2.1.4 List of IMO Conventions (4 hours)**

Instructors should refer to the IMO Conventions for reference. A brief introduction to the following conventions their relevancy and purpose should be highlighted to Trainees. The conventions related to **Maritime Safety**, example (International Convention for the Safety of Life at Sea (SOLAS), 1974; International Convention on

Load Lines (LL), 1966, Convention on the International Regulations for Preventing Collisions at Sea (COLREG), 1972; International Convention on Standards of Training, Certification and Watchkeeping for Seafarers (STCW), 1978, etc.; the Conventions related to **Marine Pollution**, example International Convention for the Prevention of Pollution from Ships, 1973, as modified by the Protocol of 1978 relating thereto (MARPOL 73/78), Convention on the Prevention of Marine Pollution by Dumping of Wastes and Other Matter (LDC), 1972, etc.; and the Conventions related to **Liability and Compensation**, example, International Convention on Civil Liability for Oil Pollution Damage (CLC), 1969; International Convention on the Establishment of an International Fund for Compensation for Oil Pollution Damage (FUND), 1971 and The Protocol of 1992, etc., and **other conventions** namely, Convention on Facilitation of International Maritime Traffic (FAL), 1965; International Convention on Tonnage Measurement of Ships (TONNAGE), 1969; Convention for the Suppression of Unlawful Acts Against the Safety of Maritime Navigation (SUA), 1988; International Convention on Salvage (SALVAGE), 1989), etc., should all be addressed in this session.

#### **4.2.1.5 Introduction to International Labour Organisation (ILO) (1 hour)**

Instructors should refer to text R60, R64, B59 and other ILO relevant resources to explain to trainees the ILO, its standards, how it works and tripartite structure it uses to enforce its standards. How ILO standards have impacted the maritime industry worldwide.

#### **4.2.1.6 World Health Organisation (WHO) (1 hour)**

Instructors should refer to text R63, and other WHO relevant resources to explain to trainees this specialized UN agency for health and how it impacts the maritime industry.

#### **4.2.1.7 Authorities and Regulations (5 hours)**

Instructors should refer to the text listed below and National Maritime Legislation to address the role and duties of a Flag State; the Port State, its role and purpose in contributing to safer ships, also the port state control procedures; the Classification Society, classes, assignments, surveys, etc; the IACS and its role in unifying standards of ships. The relevant text is: R1, R25, R26, R33, R44, R45, R56, B30, B31, B34, B40, B66, B111, V26, and V59.

### **4.2.2 CERTIFICATES AND OTHER DOCUMENTS TO BE CARRIED ON BOARD SHIPS BY INTERNATIONAL CONVENTIONS, HOW THEY MAY BE OBTAINED AND PERIOD OF THEIR LEGAL VALIDITY**

#### **4.2.2.1 List of Certificates and documents to be carried on board ships as per SOLAS Annex I, how they are obtained and their period of validity (2 hours)**

Instructors should refer to R1 for the list of certificates to be carried on board, their period of validity and how these certificates are obtained.

**4.2.2.2 Additional certificates and documents required on board ship  
(1 hour)**

Instructors should inform trainees of other additional certificates that needed to be carried with the vessel as per requirements, including, the Classification Society Certificates for Hull and Machinery, the Anchor and Chain Cable Certificate, the Inflatable Liferaft Inspection Certificates; the Official Log-book; Deck, Engine-room and Radio Log-books; crew list, passenger list, Ship Sanitation Control Exemption Certificate or Ship Sanitation Control Certificate, Maritime Declaration of Health, etc. Instructors should refer to relevant Conventions and National legislation on the additional certificates.

**4.2.3 RESPONSIBILITIES UNDER THE RELEVANT REQUIREMENTS OF THE INTERNATIONAL CONVENTION ON LOAD LINES**

**4.2.3.1 International Convention on Load Lines (3 hours)**

Instructors should refer to R1, R44, V26, for important features of this requirement, also the condition of assignment, associated surveys and certificates, fittings and appliances requirements and the effect of the varying loading conditions in the stability as indicated in the stability booklet.

**4.2.4 RESPONSIBILITIES UNDER THE RELEVANT REQUIREMENTS OF THE INTERNATIONAL CONVENTION FOR THE SAFETY OF LIFE AT SEA**

**4.2.4.1 International Convention for the Safety of Life at Sea: (2 hours)**

Instructors should give an overview of the twelve chapters of SOLAS. Instructors should consult text R1 and other relevant IMO publication.

**4.2.4.2 Obligation to carry out periodical surveys and maintain validity of following certificates: (1 hour)**

Instructors should highlight to the trainees the obligations of stakeholders to maintain ship's conditions and its certificates through periodical surveys. Instructors should refer to text R1, R3, R4, R9, R52, T39, V27, for such certificates as, Safety Management Certificate, International Ship Security Certificate, Passenger ship safety certificate, Cargo ship safety construction certificate, cargo ship safety equipment certificate, cargo ship safety radio certificate, etc.

**4.2.4.3 Obligation to maintain following records: (1 hour)**

Instructors should inform trainees of their obligation to maintain the following records: On board training and drills record; Voyage data recorder system annual performance test; Ship Security Plan records; Continuous Synopsis records. Instructors should refer to R1, R3, and B112.

**4.2.4.4 Obligation and rights of master (1 hour)**

Instructors should inform the trainees the obligations and rights of a Master of a vessel in various circumstances, such as, Obligation to navigate safely, Obligation to permit ship to Port State Control inspection, etc.

**4.2.5 RESPONSIBILITIES UNDER THE RELEVANT REQUIREMENTS OF THE INTERNATIONAL CONVENTION FOR THE PREVENTION OF POLLUTION FROM SHIPS**

**4.2.5.1 Annex I – Oil (1 hour)**

A brief overview of Annex 1 of MARPOL, its requirements, in terms of equipment, surveys, record book and plan should be conveyed to the trainees. Instructors should refer to R25, R26, R27, B10, B40, and B79.

**4.2.5.2 Annex II – Noxious Liquid Substances in Bulk (1 hour)**

Instructors should refer to text R1, R30, R37, R46, R47, R48 for guidance in preparing a brief overview on surveying of ships, certification and its relevancy to the Codes on ships carrying Noxious liquid substances in bulk.

**4.2.5.3 Annex III – Harmful substances carried in packaged form (0.5 hour)**

Instructors should consult text R1, R30 and R37 on the communication requirements for vessel carrying such cargo.

**4.2.5.4 Annex IV – Sewage (0.5 hour)**

Instructor should consult R1, on the requirements to verify adherence of the ship to this legislation, and trainees should know the ISPP certificate and its validity.

**4.2.5.5 Annex V - Garbage (1 hour)**

A brief overview and requirements on this annex should be explained to the trainees. Explanation should include the Garbage Management plan, the record book and the disposal restrictions. Instructors should refer to text R1, R29, V52

**4.2.5.6 Annex VI – Air Pollution (1 hour)**

A brief overview and requirements on this annex should be explained to the trainees. Explanation should include the Exhaust and vapour emissions, the IOPP certificate requirements, Regulation 13 regarding NO<sub>x</sub> and Regulation 14 SO<sub>x</sub>, etc. Instructors should refer to text R1, V21, V22.

#### **4.2.6 MARITIME DECLARATIONS OF HEALTH AND THE REQUIREMENTS OF THE INTERNATIONAL HEALTH REGULATIONS**

##### **4.2.6.1 WHO's International Health Regulations 2005 (IHR) (3 hours)**

The Instructor should refer to WHO International Health Regulations 2005 (IHR) and R63, R2, R1, T29 to address Ship Sanitation requirements, the Maritime Declaration of Health, public health risk assessment, etc that a ship will need to adhere.

##### **4.2.6.2 International Medical Guide for Ships (IMGS) (1 hour)**

Instructors should refer to the International Medical Guide for Ships (IMGS), R2 on the requirement for ships. Trainees should be notified on the IMGS requirements of the ships medicine chest.

##### **4.2.6.3 International Maritime Organization's Medical First Aid Guide for Use in Accidents Involving Dangerous Goods (MFAG) (0.5 hour)**

Instructors should refer to the IMO Medical First Aid Guide for Use in Accidents Involving Dangerous Goods (MFAG) on its requirements when delivering this.

##### **4.2.6.4 WHO's Guidelines for Drinking-water quality (0.5 hour)**

Instructors should consult R63 and other WHO resources when delivering issues in this section.

#### **4.2.7 RESPONSIBILITIES UNDER INTERNATIONAL INSTRUMENTS AFFECTING THE SAFETY OF THE SHIPS, PASSENGERS, CREW OR CARGO**

##### **4.2.7.1 ILO's Maritime Labour Convention 2006 (MLC 2006) (4 hours)**

Instructors to give an overview of this Labour Convention for seafarers and its principles and obligations. Instructor should refer to ILO Maritime Convention 2006 and R60, R64 when preparing to deliver this section.

##### **4.2.7.2 Convention on the International Regulations for Preventing Collisions at Sea (COLREG) 1972 (1 hour)**

Instructors should refer to text R56 as to how it affects ships, passengers and crew or cargo.

##### **4.2.7.3 International Convention on Salvage, 1989 – Lloyd's Standard Form of Salvage Agreement (LOF, 2000) (1 hour)**

R19 text should be consulted by Instructors when highlighting the requirements of this convention and its effect on safety of ships, passengers, crew and cargo.

**4.2.7.4 Convention on Limitation of Liability of Maritime Claims, 1976 (LLMC 1976)**

**(1 hour)**

Instructors should consult text R20 when addressing and preparing lesson on the Limitation of Liability of Maritime Claims. How it affects the safety of ships, passengers and crew and cargo.

**4.2.7.5 International Convention for the Unification of Certain Rules of Law Relating to Bills of Lading, as Amended by Protocol of 1968 (Hague-Visby Rules)**

**(1 hour)**

B88 should be consulted by the Instructor to guide him/her when preparing lesson on rules relating to Bill of Lading, etc.

**4.2.7.6 Charter parties**

**(3 hours)**

These texts can be used by the Instructor T26, T30, B4, B11, B17, B27, B103, to address the following to the trainees: (i) Voyage charter, (ii) Time charter, (iii) Bareboat charter, (iv) Laydays and cancelling date (Laycan), (v) Notice of readiness (NOR); (vi) Demurrage, (vii) Dispatch, (viii) Delivery – On hire, (ix) On hire survey, (x) Redelivery – Off hire, (xi) Off hire survey

**4.2.7.7 Marine Insurance, General Average and P & I Club**

**(4 hours)**

Instructors should refer to the following text B5, B8, B9, B19, B24, B26, B61, B83, and V90, when preparing their lesson plan. Areas to be covered should include Marine insurance, marine losses, hull and machinery insurance, oil pollution liabilities, P&I insurance, its cover and cost.

**4.2.8 METHODS AND AIDS TO PREVENT POLLUTION OF THE ENVIRONMENT BY SHIPS**

**4.2.8.1 List of Convention – (Refer 4.2.1.4 under "Conventions related to Marine Pollution")**

Instructors should refer to 4.2.1.4 under the conventions related to Marine pollution and give an overview of their purpose to the trainees.

**4.2.8.2 Sources of Marine pollution**

**(1 hour)**

Instructors should refer to R25, V21, V22, to highlight to trainees the sources of the following pollutants: Oil, Noxious liquid substances carried in bulk, Harmful substances carried by sea in packaged form, Sewage, Garbage, Air, Ballast water, Anti-fouling paints, Noise.

**4.2.8.3 Effects of marine oil spills (1 hour)**

Instructors can use latest multimedia production of major oil spills such as the Exxon Valdez, and other catastrophes to communicate to the trainees the devastating effect of oil pollution to the marine environment. Also instructors can consult text B75.

**4.2.8.4 Regulations for prevention of oil pollution as per Annex I of MARPOL 73/78 (4 hours)**

Instructors should inform trainees of the requirements for (i) Tanks for oil residues (Sludge), (ii) Oily water separator and oil filtering equipment and oil content monitoring, (iii) Standard discharge connection, (iv) Control of oil discharge – discharge in special areas and outside special areas, (v) Oil record book, (vi) Requirement for oil tankers, such as, Double hull and double bottom tank, Intact stability requirements, Subdivision and damage stability, Slop tanks, Pumping, piping and discharge arrangement, Oil monitoring and control system, Requirements for crude oil washing, Control of discharge of oil from oil tankers - Discharge outside special areas and Discharge in special areas, Shipboard oil pollution emergency plan, Reception facilities, Concept of Integrated Bilge Water Treatment System (IBTS). Instructors should utilize text R1, R25, R26, R27, R33, R36, R37, B39, B40, B44, B48, B54 B74, B76, B79 B97, B98, B111, and V22,.

**4.2.8.5 Regulations for control of pollution from Noxious liquid substances carried in bulk as per Annex II of MARPOL 73/78 (1 hour)**

Instructors should refer to R1, R25, R46, R47, R48 and the IMO publications on The International Code for the Construction and Equipment of Ships Carrying Dangerous Chemicals in Bulk (IBC Code), the Code for the Construction and Equipment of Ships Carrying Dangerous Chemicals in Bulk (BCH Code) and the Code for the Construction and Equipment of Ships Carrying Liquefied Gases in Bulk (IGC Code)

**4.2.8.6 Regulations for the Prevention of Pollution by Harmful substances carried by sea in packaged form as per Annex III of MARPOL 73/78 (0.5 hour)**

Instructor to refer to R1 and R25 on this subject.

**4.2.8.7 Requirements covering the carriage of dangerous goods by sea as per Chapter VII of the SOLAS Convention (0.5 hour)**

Instructor should consult R1 and other IMO publications to deliver on the following

- Carriage of dangerous goods in packaged form and IMDG Code
- Carriage of dangerous goods in solid form in bulk
- Chapter VII of SOLAS and the IMDG Code is safety, successful application of their provisions benefits the marine environment-by reducing pollution from harmful substances.

**4.2.8.8 Regulations for the Prevention of Pollution by Sewage from Ships as per Annex IV of MARPOL 73/78 (2 hours)**

Instructor should consult R1, R25, and other IMO publications to deliver on the following: (i) Harmful effects of sewage to the marine environment, (ii) sewage treatment plant; system to comminute and disinfect the sewage; and a holding tank, (iii) standard discharge connections, (iv) discharge of sewage, (v) reception facilities.

**4.2.8.9 Regulations for the Prevention of Pollution by Garbage from Ships as per Annex V of MARPOL 73/78 (2 hours)**

Instructor should consult R1, R25, R26 R27, R29, and other IMO publications to deliver on the subject and highlighting to trainees the following:

- placards, garbage management plans and garbage record keeping
- shipboard incinerators
- disposal of garbage outside special areas
- disposal of garbage within special areas
- reception facilities

**4.2.8.10 Regulations for the Prevention of Air Pollution as per Annex VI of MARPOL 73/78 (3 hours)**

Instructor should consult R1, R25, R26 R27, V21 and other IMO publications to deliver on the subject and highlighting to trainees the following:

- Use of ozone depleting substances prohibited on ships. Use of HCFCs permitted till 1st January 2020.
- Sulphur content of any fuel oil used on board ships shall not exceed 4.5% m/m and a progressive reduction in sulphur initially to 3.50% effective from 1 January 2012; then progressively to 0.50%, effective from 1 January 2020, subject to a feasibility review to be completed no later than 2018.
- The sulphur content limits applicable in Sulphur Emission Control Areas is 1.00% and will be further reduced to 0.10%, effective from 1 January 2015 or an exhaust gas cleaning system, approved by the Administration.
- Bunker delivery notes and representative sample to be retained.
- NO<sub>x</sub> technical file on board ship as per NO<sub>x</sub> Technical Code 2008 for all marine diesel engines with a power output of 130 kW or more Vapour collection system for tankers for control of volatile organic compounds
- Shipboard incineration and guidelines for use of incinerator.

**4.2.8.11 International Convention for the Control and Management of Ship's Ballast Water and Sediments (2 hours)**

Instructor should refer to R1, R25, R26, R27, R39, R40, and other IMO publications to deliver on the subject and highlighting to trainees the following:



- Ballast water treatment or exchange, depending upon year of built and size of ship
- Ballast Water Management Plan
- Ballast Water Record Book
- All ships using ballast water exchange should whenever possible, conduct ballast water exchange at least 200 nautical miles from the nearest land and in water at least 200 metres in depth.

#### **4.2.8.12 Anti-fouling paints**

**(1 hour)**

Instructor should consult R1, R25, R43 and other IMO resources to deliver on the subject and highlighting to trainees that Ships could no longer be coated with TBT-based antifouling and those vessels coated with it have them removed have a barrier coating to prevent their leaching

#### **4.2.8.13 Noise**

**(1 hour)**

Instructor should consult R1, R25, IMO Assembly resolution A468 (XII) – Code on noise levels on board ships to address the subject to trainees.

### **4.2.9 NATIONAL LEGISLATION FOR IMPLEMENTING INTERNATIONAL AGREEMENTS AND CONVENTIONS**

Instructors should consult R1 and the National Legislation to deliver this subject. Instructors should develop their own objectives here to ensure that national legislation, that is the flag state laws are covered to an extent that meets or exceeds the standards laid down in the international conventions, codes and agreements. Emphasis should be on monitoring compliance, identifying areas where there may be potential for non-compliance or differences compared to international standards.

## **4.3 MAINTAIN SAFETY AND SECURITY OF THE VESSEL, CREW AND PASSENGERS AND THE OPERATIONAL CONDITION OF THE LIFESAVING, FIRE FIGHTING AND OTHER SAFETY SYSTEMS**

### **4.3.1 LIFE SAVING APPLIANCES REGULATIONS (SOLAS)**

#### **4.3.1.1 Life-saving appliances and arrangements (Chapter III of SOLAS) and Life-Saving Appliance Code**

**(2 hours)**

Instructor should consult R1, R61, V54, V99, and V100 to address the subject to the trainees.

### **4.3.2 ORGANISATION OF FIRE AND ABANDON SHIP DRILL**

#### **4.3.2.1 Organisation of Fire and Abandon Ships Drills**

**(1 hour)**

Instructor should consult R1, R6, V24, and B112, to address the subject to the trainees.

### **4.3.3 MAINTENANCE OF LIFE-SAVING, FIRE-FIGHTING AND OTHER SAFETY SYSTEMS**

#### **4.3.3.1 Maintenance of Life-saving, Fire-fighting and Other Safety Systems (3 hours)**

Instructor should consult R1, R61, R6, V28, B112 V54, V99, V100 to address the subject to the trainees.

### **4.3.4 ACTIONS TO BE TAKEN TO PROTECT AND SAFEGUARD ALL PERSONS ON BOARD IN EMERGENCIES**

#### **4.3.4.1 Actions to protect and safeguard all persons on board in emergencies; Rescue of persons from a vessel in distress or from a wreck; and Man-overboard procedures (1 hour)**

Instructor should consult R1, R6, V29-V39, B112 V54, to address the subject to the trainees.

The standard full-speed man-overboard maneuvers, such as the Williamson turn, are not possible in very heavy weather. Turning at speed into a heavy sea and swell could cause serious damage to the ship. The turn should be made in the safest way possible in the conditions and the ship maneuvered into a position to windward of the person in the water. The ship will quickly drift down to him. A few fit crew members, wearing immersion suits, lifejackets and lifelines, should be standing by to help the person on board. Use may also be made of the line-throwing apparatus, with a buoyant head, to drift a line to the person in the water. It is essential to keep the person in sight throughout the operation, and this is difficult in a heavy sea and swell, so any crew not otherwise occupied in the rescue should be posted as look-outs.

When a person is reported to the master as missing, it may reasonably be assumed that efforts have already been made to find him. A final call on the public address system should be made and if there is no response the ship should be turned into its wake and a search along the reciprocal course made. At the same time, a thorough search of the ship should be organized and the time at which the missing person was last seen should be established. The track should be searched back to the position where it is known the person was still on board. An urgency call requesting other ships in the vicinity to keep a look-out for the person should be made.

### **4.3.5 ACTION TO LIMIT DAMAGE AND SALVE THE SHIP FOLLOWING FIRE, EXPLOSION, COLLISION OR GROUNDING**

#### **4.3.5.1 Contingency plans for response to emergencies (1 hour)**

Instructor should consult R1, R6, B112, V24, V37, V43, and V58, to address the subject to the trainees.

#### **4.3.5.2 Means of limiting damage and salvaging the ship following a fire or explosion (1 hour)**

Instructor should consult R1, R54, B112 and V54, to address the subject to the trainees.

No definite procedures can be laid down as each occurrence will be unique. Trainees should consider the measures which could be taken in a variety of situations, using materials to be found aboard ship.

It is important to keep observation on damaged areas and temporary repairs, to ensure that there is immediate warning of a worsening situation.

#### **4.3.5.3 Procedures for abandoning ship (1 hour)**

Instructor should consult R1, R6, B112, V24, V37 V43, and V58, to address the subject to the trainees.

A ship should not be abandoned prematurely. It is generally safer to remain aboard a wreck, to await the arrival of assistance, for as long as possible. This is particularly true in severe weather conditions, when abandoning ship is very hazardous and the condition of the crew will deteriorate rapidly in survival craft. Also, in those conditions, craft are likely to become widely dispersed, making rescue more difficult.

When the condition of the ship is such that sinking or breaking up is inevitable, the ship should be abandoned in time to get clear of her before she sinks or before wreckage makes the launching of survival craft dangerous. In the event of fire or explosion or of the release of toxic fumes it may be essential to get clear of the ship as quickly as possible.

Consideration should be given to the method of passing the 'abandon ship' signal. It should be distinctive, so that it is not confused with other signals or instructions which may be given in an emergency. The instruction to abandon ship may have to be given by word of mouth if other communication systems have broken down.

The duties of the emergency party should include provision for the shutting down of any machinery, as required.

### **4.4 DEVELOP EMERGENCY AND DAMAGE CONTROL PLANS AND HANDLE EMERGENCY SITUATION**

#### **4.4.1 SHIP CONSTRUCTION, INCLUDING DAMAGE CONTROL**

Refer to 4.1.1

#### **4.4.2 METHODS AND AIDS FOR FIRE PREVENTION, DETECTION AND EXTINCTION**

##### **4.4.2.1 Fire-fighting equipment (3 hours)**

Instructors to consult V24, V53, R51, T7, T11 and T15 to explain the construction, installation and operation of fixed fire fighting installations, portable and semi portable fire-fighting equipment

#### **4.4.3 FUNCTIONS AND USE OF LIFE-SAVING APPLIANCES**

##### **4.4.3.1 Life-saving appliances (2 hours)**

Instructors to consult V54, V99, R61, T7, T11 and T15 to explain the following:

- Construction, installation and operation of life saving equipment.
- Tests, procedures and maintenance necessary to ensure correct and safe operation of life-saving and other safety equipment.
- Maintenance of water tight doors.

#### **4.5 USE LEADERSHIP AND MANAGERIAL SKILLS**

Officers will have different experiences of personnel management. As officers in charge of a watch they will also have had to exercise their authority. They will therefore recognize and understand many of the learning objectives. It should be possible to build on this and use their prior experience to the maximum to improve their knowledge and ability to cope with seagoing and other personnel such as pilots, ship agents, ship repairers and other shore staff.

There should also be a good opportunity to establish useful facts on the varying conditions of employment experienced by the group of trainees and perhaps to learn something of the advantages and disadvantages of the various systems which the trainees might find to be helpful in the course of their duties.

If time permits, the trainees should be given group assignments to recreate and learn how to deal with some of the typical arguments and problems which occur on board ship (V4).

#### **Organization of Staff**

Once again, the experience of the trainees can be used as a basis to develop the various aspects of organizing staff. It is a wide subject and will vary according to the type of ship and, in some cases, the requirements of an Administration.

## **KNOWLEDGE OF SHIPBOARD PERSONNEL MANAGEMENT AND TRAINING**

### **4.5.1.1 Engineer and Manager (1 hour)**

Instructors to consult V37 and V43 for this subject to enable trainees understand definition of management and functions, characteristics and skills of engineers, supervisor and managers.

### **4.5.1.2 Human Resource Management (1 hour)**

Instructors to consult V37 and V43 for this subject to enable trainees understand the importance of crew management on board vessels.

### **4.5.1.3 Training and Development (2 hours)**

Instructors to consult V93, V94 and B112 for this subject to explain

- Staff appraisal.
- Training needs analysis.
- Planning and organisation of training programmes.
- Training methods.
- Debriefing after training exercises.
- Evaluation of training programmes.

### **4.5.1.4 Maintenance Management (2 hours)**

Instructors to consult R4 for this subject to explain

- Maintenance techniques.
- Machinery maintenance and surveys planning and organisation.
- An insight into Reliability Centred Maintenance.

Instructors are also advised to go through the websites of various classification societies to gain vital information, to be passed on to the trainees. An example could be the American Bureau of Shipping web page <http://www.eagle.org>.

## **4.5.1 KNOWLEDGE OF INTERNATIONAL MARITIME CONVENTIONS AND RECOMMENDATIONS AND RELATED NATIONAL LEGISLATIONS**

### **4.5.1.1 The ISM Code**

(Refer to 4.2.4.1)

### **4.5.1.2 STCW Convention (1 hour)**

Instructors to consult R57 and R59 for this subject to explain to the trainees hours of work and hours of rest.

#### **4.5.1.3 ILO's MLC 2006**

(Refer to 4.2.7.1/2/3/4)

### **4.5.3 ABILITY TO APPLY TASK AND WORKLOAD MANAGEMENT**

#### **4.5.3.1 Communication (1 hour)**

Instructors to consult V48, V93 and V94 for this subject to explain

- Verbal and non-verbal communication.
- Report writing. Presentation.
- Group discussion.
- Meetings.

#### **4.5.3.2 Team Building (1 hour)**

Instructors to consult V46 for this subject to explain

- Importance of work teams.
- Group dynamics.
- Approaches to team building. Committees.

#### **4.5.3.3 Planning and Co-ordination (1 hour)**

Instructors to consult V44 and V45 for this subject

#### **4.5.3.4 Personal assignments (1 hour)**

Instructors to consult V44, V45 and V46 for this subject

#### **4.5.3.5 Time and resource constraints (1 hour)**

Instructors to consult V44, V45 and V46 for this subject

#### **4.5.3.6 Prioritization (1 hour)**

Instructors to consult V44, V45 and V46 for this subject

### **4.5.4 KNOWLEDGE AND ABILITY TO APPLY EFFECTIVE RESOURCE MANAGEMENT**

#### **4.5.4.1 Allocations, assignment and prioritization of resources (1 hour)**

Instructors to consult V43, V44 and V45 for this subject

#### **4.5.4.2 Effective communications on board and ashore (1 hour)**

Instructors to consult V37 and V48 for this subject

---

**4.5.4.3 Decisions reflect consideration of team experience (1 hour)**

Instructors to consult V37 and V46 for this subject

**4.5.5 KNOWLEDGE AND ABILITY TO APPLY DECISION-MAKING TECHNIQUES**

**4.5.5.1 Management Processes and Functions (2 hours)**

Instructors to consult V31, V37, V43, V44, V45, V93 and V94 for this subject to explain topics on:

- Management processes.
- Management functions.
- Motivation.
- Conflict resolution

**4.5.5.2 Negotiating Skills (2 hours)**

Instructors to consult V37, V43, V44 and V45 for this subject to explain

- Negotiation process.
- Necessary skills for successful negotiation.
- Planning for negotiation.

**4.5.5.3 Situation and risk assessment (1 hour)**

Instructors to consult V94 for this subject

**4.5.5.4 Identify and generate options (1 hour)**

Instructors to consult V37 and V43 for this subject

**4.5.5.5 Select course of action (1 hour)**

Instructors to consult V37 and V43 for this subject

**4.5.5.6 Evaluation of outcome effectiveness (1 hour)**

Instructors to consult V37 and V43 for this subject

**4.5.6 DEVELOPMENT, IMPLEMENTATION, AND OVERSIGHT OF STANDARD OPERATING PROCEDURES**

**4.5.6.1 Project Planning and Controlling (3 hours)**

Instructors to consult V37, V43 and T39 for this subject to explain

- Project planning and controlling process.
- GANTT charts.
- Critical Path Method

- Programme Evaluation and Review Techniques
- Application of Fault Tree Analysis and similar Reliability Engineering Techniques to solve practical shipboard problems.

Also refer to the websites of classification societies to gain vital information, to be passed on to the trainees. An example could be the American Bureau of Shipping web page <http://www.eagle.org>.



## Part E: Evaluation

The effectiveness of any evaluation depends to a great extent on the precision of the description of what is to be evaluated. The detailed teaching syllabus is thus designed, to assist the Instructors, with descriptive verbs, mostly taken from the widely used Bloom's taxonomy.

Evaluation/Assessment is a way of finding out if learning has taken place. It enables the assessor (Instructor), to ascertain if the learner has gained the required skills and knowledge needed at a given point towards a course or qualification.

### **The purpose of evaluation/assessment is to:**

- To assist student learning.
- To identify students' strengths and weaknesses.
- To assess the effectiveness of a particular instructional strategy.
- To assess and improve the effectiveness of curriculum programs.
- To assess and improve teaching effectiveness.

The different types of evaluation/assessment can be classified as:

### **Initial/Diagnostic assessment**

This should take place before the trainee commences a course/qualification to ensure they are on the right path. Diagnostic assessment is an evaluation of a trainee's skills, knowledge, strength and areas for development. This can be carried out during an individual or group setting by the use of relevant tests.

### **Formative assessment**

Is an integral part of the teaching/learning process and is hence is a "Continuous" assessment. It provides information on trainee's progress and may also be used to encourage and motivate them.

#### **Purpose of formative assessment**

- To provide feedback to students.
- To motivate students.
- To diagnose students' strengths and weaknesses.
- To help students to develop self-awareness.

### **Summative assessment**

It is designed to measure trainee's achievement against defined objectives and targets. It may take the form of an exam or an assignment and takes place at the end of a course.

#### **Purpose of summative assessment**

- To pass or fail a trainee
- To grade a trainee

The instructors need to consider the best way to assess the skills, knowledge and attitudes of our learners, whether this will be formative and/or summative and how the assessment will be valid and reliable.

All work assessed should be valid, authentic, current, sufficient and reliable; this is often known as VACSR – "valid assessments create standard results".

- Valid – the work is relevant to the standards/criteria being assessed;
- Authentic – the work has been produced solely by the learner;
- Current – the work is still relevant at the time of assessment;
- Sufficient – the work covers all the standards/criteria;
- Reliable – the work is consistent across all learners, over time and at the required level.

It is important to note that no single methods can satisfactorily measure knowledge and skill over the entire spectrum of matters to be tested for the assessment of competence.

Care should therefore be taken to select the method most appropriate to the particular aspect of competence to be tested, bearing in mind the need to frame questions which relate as realistically as possible to the requirements of the officer's job at sea.

## **STCW Code 2010**

The training and assessment of seafarers, as required under the Convention, are administered, supervised and monitored in accordance with the provisions of section A-I/6 of the STCW Code.

Column 3 - Methods for demonstrating competence and Column 4 - Criteria for evaluating competence in Table A-III/2 (Specification of minimum standard of competence for chief engineer officers and second engineer officers on ships powered by main propulsion machinery of 3,000 kW propulsion power or more) of STCW Code 2010, sets out the methods and criteria for evaluation. Instructors should refer to this table when designing the assessment.

Assessment is also covered in detail in another IMO Model Course, however to assist and aid the Instructors, some extracts from the Model course is used to explain in depth.

When evaluation consists of calculations, the following should be taken into consideration:

### **Calculations**

To carry out their duties, chief engineer officers and second engineer officers must be able to solve technical problems by performing calculations in various subject areas such as cargo work, ship stability and navigations calculations.

The ability to perform such calculations and to resolve such problems can be tested by having the candidates carry out the calculations in their entirety. Since a large variety of technical calculations is involved and the time necessary for their complete solution is considerable, it is not possible to completely test the abilities of candidates within a reasonable examination time.

Resort must therefore be made to some form of sampling technique, as is the case with the assessment of knowledge, comprehension and application of principles and concepts in other subject fields.

In examinations conducted on a traditional essay-type basis, the sampling technique that is applied in respect of calculation requirements is to attempt to cover as much of the subject area as possible within the examination time available. This is frequently done by using questions involving shorter calculations and testing in depth on one or two topics by requiring the completion of more complex calculations. The employment of this 'gross sampling' technique reduces the reliability of the examination as compared with what can be achieved with a more detailed sampling technique.

A greater breadth of sampling can be achieved by breaking down calculations into the various computational steps involved in their solution. This technique can only be applied to calculations in which the methodology is standardized. Fortunately, most calculations follow a standard format; where alternative methods of solution exist, the examination can be developed so as to allow candidates an appropriate freedom of choice. Such freedom of choice must be a feature of examinations of all types, in any event.

In order to develop a series of 'step test items', covering an entire calculation, it is necessary to identify each intermediate step in each calculation involved by all methods which are accepted as being correct in principle. These questions, after they have been reviewed for clarity and conciseness, form the standard 'step test items' in that calculation topic.

This approach allows questions to be posed which sample the candidate's knowledge and ability to perform parts of various calculations, which process takes up less time than having him perform entire calculations. The assumption is made that if the candidate can or cannot correctly complete a calculation step leading to the solution, then he can or cannot successfully carry out the entire calculation. Such detailed sampling allows a larger number of questions to be answered by the candidate within the time allotted for the examination, thus allowing a broader sampling of the candidate's knowledge and abilities, thereby increasing the reliability of the examination.

It must be pointed out that because of the greater number of test items used more time will be spent by candidates in reading the questions and in appreciating the precise step which each question involves.

However, the ability to answer correctly questions that are based on each intermediate step leading to the solution does not necessarily indicate competence in the application of the calculation methodology nor in the interpretation of the intermediate or final results. Further questions must therefore be developed which are of a 'procedural' and principle nature.

Such 'step test' and 'procedural' items may be drawn up as 'essay-type' items, supply-type items or multiple-choice items. Marking or scoring is easier if multiple-choice test items are used, but in some cases difficulties may arise in creating plausible distracters.

Detailed sampling can allow immediate identification of errors of principle and those of a clerical nature. It must be emphasized that this holds true, in general, only if the test item is based on a single step in the overall calculation. Multiple-choice items involving more than one step may, in some cases, have to be resorted to in order to allow the creation of a sufficient number of plausible distracters, but care must be exercised to ensure that distracters are not plausible for more than one reason if the nature of the error made (and hence the distracter chosen) is to affect the scoring of the test item.

## **Compiling tests**

Whilst each examining authority establishes its own rules, the length of time which can be devoted to assessing the competence of candidates for certificates of competency is limited by practical, economic and sociological restraints. Therefore a prime objective of those responsible for the organization and administration of the examination system is to find the most efficient, effective and economical method of assessing the competency of candidates. An examination system should effectively test the breadth of a candidate's knowledge of the subject areas pertinent to the tasks he is expected to undertake. It is not possible to examine candidates fully in all areas, so in effect the examination samples a candidate's knowledge by covering as wide a scope as is possible within the time constraints and testing his depth of knowledge in selected areas.

The examination as a whole should assess each candidate's comprehension of principles, concepts and methodology; his ability to apply principles, concepts and methodology; his ability to organize facts, ideas and arguments and his abilities and skills in carrying out those tasks he will be called upon to perform in the duties he is to be certificated to undertake.

All evaluation and testing techniques have their advantages and disadvantages. An examining authority should carefully analyse precisely what it should be testing and can test. A careful selection of test and evaluation methods should then be made to ensure that the best of the variety of techniques available today is used. Each test shall be that best suited to the learning outcome or ability to be tested.

## Quality of test items

No matter which type of test is used, it is essential that all questions or test items used should be as brief as possible, since the time taken to read the questions themselves lengthens the examination. Questions must also be clear and complete. To ensure this, it is necessary that they be reviewed by a person other than the originator. No extraneous information should be incorporated into questions; such inclusions can waste the time of the knowledgeable candidates and tend to be regarded as 'trick questions'. In all cases, the questions should be checked to ensure that they measure an objective which is essential to the job concerned.

## SCORING TESTS

### Scoring subjective tests

The assessment of seafarers is concerned with judging whether they are competent, in terms of meeting sufficient specified learning objectives, to perform the tasks required by the qualification they are seeking. That is, they should be tested against predetermined criteria rather than against the performance of other examinees or the norm for the group as a whole, as is the case in many examinations.

To achieve that end in subjective tests, an analytical scoring scheme should be drawn up in which a complete model answer, which would attract full marks, is produced for each question. The model answer is then analysed for the definitions, facts, explanations, formulae, calculations, etc., contained in it and marks are allocated to each item, the aim being to make the scoring as objective as possible. A subjective element will still exist in the original allocation of marks to the various sections and, to some extent, in the scoring of incomplete or partially correct sections.

Either credit scoring or deductive scoring may be used. In credit scoring, marks are awarded, in accordance with the scoring scheme, for each correctly completed part of the answer, no marks being credited for incorrect parts or omissions. With deductive scoring, marks are deducted for errors and omissions from the total mark for the question or part question (where a question has been divided into two or more sections). When applied to essay questions, the two methods should produce virtually the same score. Deductive scoring is usually confined to the marking of calculations.

Deductive scoring can be weighted to take account of the relative seriousness of different types of error. Errors are commonly classed and weighted as follows:

- .1 errors of principle; for example, using the formula for righting moment in a calculation of list; deduct 50% of the mark for the question or part question;
- .2 major errors; for example, extracting data for the wrong day or time from a publication; deduct 30% of the mark for the question or part question; and

- .3 clerical errors; for example, transposition of numbers from tables or question paper, careless arithmetic; deduct 10% of the mark for the question or part question for each error.

In the case of clerical errors, only one deduction for a single error should be made. No deductions are made for incorrect answers which follow through from the original error. If deductions exceed the total mark for a question or part question it is given a zero score; negative scores are not carried over to other parts.

The different types of error can be taken into account in credit scoring schemes by suitably weighting the marks allocated to method, to the extraction of data and to clerical accuracy at each step of the calculation. The steps need to be smaller and more detailed than the division into parts used in deductive marking. As a result, the marks lost for errors of principle tend to be smaller in credit scoring than in deductive scoring.

A small percentage of the total mark, to be credited only for the correct final answer, is sometimes included in a credit scoring scheme. The answer must lie within stated accuracy limits to qualify for that credit. In deductive schemes, an answer that has otherwise been correctly calculated but which falls outside the accuracy limits is treated as a clerical error.

Where tests are to be marked locally at more than one test centre, a well-defined scoring scheme, which will give the same score when applied to the same paper by different markers, is essential for the uniform and fair treatment of candidates. To aid in any subsequent review of marks, possibly resulting from an appeal, the marker should make brief marginal notes on the paper to indicate the reasons for deductions.

Guidance on the treatment of answers produced by pocket calculators is needed. Examination rules usually warn candidates that all working must be shown to gain full marks for a question. The marks to deduct when insufficient working is shown but a correct answer is produced, or when all working is correctly shown but the answer is wrong, need to be known by the marker.

In papers in which all questions are to be answered, the marks may be weighted to reflect the importance or difficulty of individual questions or the length of time which will be needed to answer them. When this is done, it is usual to indicate: the mark for each question on the question paper. Optional questions should all be of similar standard and carry equal marks, so that the standard of the complete test is the same regardless of the questions chosen.

Use can be made of a compulsory and an optional section in the same paper. Questions on which it is felt that all candidates should be tested can be placed in the compulsory section and suitably weighted, while the remainder of the paper offers a choice of questions each of similar standard.

A problem that arises with optional papers is how to deal with cases where more than the required number of questions is answered. Various solutions 'are adopted by different examining boards. Many mark all questions and discard the lowest marked question or questions. Although that fact is not generally advertised as it may encourage candidates to attempt extra questions. Others take the requisite number of answers in the order in which they are on the question paper and ignore the remainder. A similar problem arises in papers in which candidates are required to answer a given number of questions and including at least some stated number from each of several sections.

The pass mark should be set at the lowest score for which sufficient skills and knowledge are demonstrated for competency in each subject. In practice, that score is difficult to determine exactly for an individual paper and could vary slightly from one examination to another. Such an arrangement would be difficult to administer and would be considered unfair by candidates, so the pass mark is fixed and published in the examination regulations. It is, therefore, essential when preparing papers to maintain as constant a standard as possible, such that the pass mark is an appropriate measure of competency.

The following instructions are typical of those produced for guidance of examiners on the marking of examinations:

In order to achieve uniformity in marking between the Examiners in various centres and to facilitate the review of papers, the following guidelines are to be used at all centres:

.1 When several candidates write the same examination, papers, other than multiple choice, should be marked question by question, that is to say, question 1 of paper 1 should be marked for all applicants before proceeding to question 2, etc. This gives more uniform marking.

.2 All questions should be marked even if it becomes apparent that the candidate cannot achieve the pass mark.

.3 Neatness and Orderly Layout of Work:

Where work is not properly laid out or is not neat, marks should be deducted without regard to correctness of the answer. The number of marks deducted should vary according to the quality of the work up to a maximum of 10% where the correct answer is obtained.

.4 Important Engineering and Technical Terms:

Where, in general calculations or general questions, an incorrect term is used and such a term is incidental to the work, the Examiner should exercise his judgment as to whether or not marks should be deducted, but in any case, a deduction should not exceed 10% of the allotted marks. This does not apply to direct answers involving definitions or in answers involving the naming of parts.

.5 Types of Errors:

Errors can be divided into 3 types:

- (a) P – error in principle; 50% of marks allotted for the whole or part of the question should be deducted.
- (b) C – clerical error; 10% of the marks allocated should be deducted for each such error.
- (c) M – major error, 30% of the marks allotted for the question or part of the question should be deducted.

NOTE: Large mark questions should be considered in their main sections and percentages of the sections deducted. Candidates should be given the benefit of any doubt which may exist.

.6 Drawings:

Too much importance should not be attached to elaborate drawings. Often a simple sketch with captions is very explanatory and indicative of a good understanding.

.7 Incomplete Answers:

Where a problem or distinct section of a large problem is only partly worked and a step of principle remains to be made, marks allotted should not exceed 50% of the total marks or the split marks allotted as the case may be.

## **MARKING PAPERS:**

- .8 When marking papers, examiners should enter appropriate marginal notes in brief showing why marks have been deducted, using abbreviations in Paragraph 5. The actual error should be ringed and marked with a brief statement of the reason for the error, e.g., 'wrong answer'. A paper should be so marked that any reviewing Examiner can see at a glance just what happened, including a marginal note to indicate award of a 'benefit of doubt'.
- .9 In the case of marginal failure, the paper concerned should be carefully reviewed. This review is not to be regarded as having the purpose of passing the candidate; it is to ensure that the foregoing marking standards have been correctly applied and are consistent with those of other responses to the same examination. It may result in either an increase or a decrease in marks assigned. This review having been completed, the examiner should issue a fail result if it is still below the pass mark.



.10 Use of Calculators:

When a pocket, non-programmable calculator is used by a candidate in an examination, all necessary formulae and transpositions must be shown for full marks to be allotted. In the case of a correctly set out answer, or partial answer, which has an incorrect final result, 30% of the whole or part should be deducted on the major error rule.

When the evaluation consists of oral and practical tests, which, many topics as per the table A-III/2, column 2, Knowledge, Understanding and Proficiency, require, the following should be taken into consideration.

**Advantages and disadvantages of oral and practical tests**

It is generally considered advisable that candidates for certificates of competency should be examined orally. Some aspects of competency can only be properly judged by having the candidate demonstrate his ability to perform specific tasks in a safe and efficient manner. The safety of the ship and the protection of the marine environment are heavily dependent on the human element. The ability of candidates to react in an organized, systematic and prudent way can be more easily and reliably judged through an oral/practical test incorporating the use of models or simulators than by any other form of test.

One disadvantage of oral/practical tests is that they can be time-consuming. Each test may take up about 1 to 2 hours if it is to comprehensively cover the topics concerned. Equipment must also be available in accordance with the abilities that are to be tested. Some items of equipment can economically be dedicated solely for use in examinations.

**GUIDANCE ON IMPLEMENTATION OF IMO MODEL COURSES**

---